

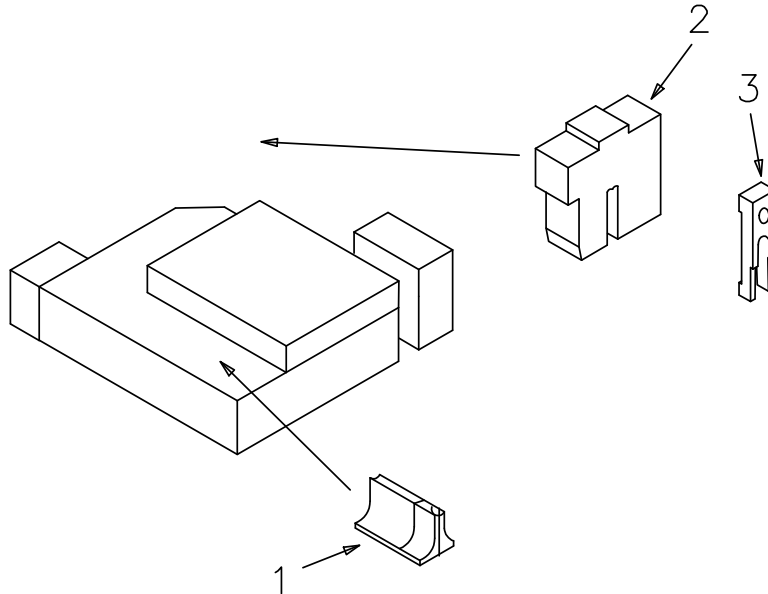

APPLICATOR No. 69015-6001
PRODUCT NUMBER 90100/103 22-26 AWG



<u>ITEM</u>	<u>PART NUMBER</u>	<u>DESCRIPTION</u>
1	-69,015	CRIMP ANVIL
2	-69,015	CRIMP DIE
3	-69,015	INSULATION DIE
4	-69,015	TOOK KIT (ITEMS 1-3)

PRODUCT SPECIFICATION: (SEE ALSO PRODUCT SPEC. CS. 90100/103)

<u>WIRE mm2 (AWG)</u>	<u>CRIMP HEIGHT (COND)</u>	<u>PULL FORCE (MIN)</u>
0.11/0.03 (28-32)	0.59/0.66 mm (.023"/.026")	See AS 90100

WIRE STRIP LENGTH: - 2.8 / 3.3 mm (.110"/.130")