

## MEMS Flow Sensor D6F-series

### User's Manual

MEMS Flow Sensor



---

## INDEX

<b>1</b>	<b>OUTLINE</b> .....	<b>2</b>
<b>2</b>	<b>WHAT IS A FLOW SENSOR?</b> .....	<b>2</b>
<b>3</b>	<b>STRUCTURE</b> .....	<b>2</b>
3.1	BASIC COMPOSITION OF FLOW SENSORS.....	2
3.2	FLOW SENSOR PRODUCT LINEUP.....	3
<b>4</b>	<b>OPERATING PRINCIPLE</b> .....	<b>4</b>
4.1	BASIC STRUCTURE OF MEMS FLOW SENSOR CHIP .....	4
4.2	DETECTING PRINCIPLE OF MASS FLOW SENSOR.....	6
<b>5</b>	<b>PRODUCT FEATURES</b> .....	<b>7</b>
5.1	CHARACTERISTICS OF FLOW SENSORS .....	7
5.1.1	<i>Detection range of flow sensors</i> .....	8
5.1.2	<i>Output signal (operating characteristics)</i> .....	8
5.1.3	<i>Permission pressure performance</i> .....	9
5.1.4	<i>Repeatability</i> .....	9
<b>6</b>	<b>USAGE OF FLOW SENSOR</b> .....	<b>9</b>
6.1	ELECTRICAL CONNECTION .....	9
6.2	PORT STYLE AND INSTALLATION METHOD.....	10
6.2.1	<i>Screw type</i> .....	10
6.2.2	<i>Quick fastener type</i> .....	10
6.2.3	<i>Manifold mount type</i> .....	11
6.2.4	<i>Bamboo type</i> .....	12
6.3	ATTENTION FOR PIPING AND CONNECTION .....	13
6.3.1	<i>Cleanup of the inflow gas</i> .....	13
6.3.2	<i>Stabilization</i> .....	13
6.3.3	<i>Measurement of high flow</i> .....	13
6.3.4	<i>Consideration of the laminar flow</i> .....	14
6.4	THE INFLUENCE OF ENVIRONMENT .....	14
6.4.1	<i>Temperature characteristics</i> .....	15
6.4.2	<i>The influence of dust</i> .....	15
6.4.3	<i>The influence of pressure and temperature</i> .....	16
6.4.4	<i>The influence of the mounting direction</i> .....	16
6.4.5	<i>Output changes in various gases</i> .....	17
6.4.6	<i>The behavior in over flow rate range</i> .....	17
6.4.7	<i>The influence of humidity</i> .....	17
6.5	APPLICATION EXAMPLE .....	18
<b>7</b>	<b>GLOSSARY</b> .....	<b>19</b>
<b>8</b>	<b>WARRANTY AND LIMITED LIABILITY</b> .....	<b>21</b>

## 1 Outline

This application note explains the features, basic usage and some notices of OMRON MEMS Flow Sensor (D6F series) before use.

## 2 What is a Flow Sensor?

A flow sensor is a sensor that detects the flow rate and flow velocity of a gas. In general, there are various types of flow sensors, such as a propeller type, a float type, an ultrasonic type, a hot wire type, and so on. OMRON flow sensors adopt a MEMS heat wire type, and have relatively excellent characteristics in comparison with other types of flow sensors.

Table1. Various Types of Flow Sensor and Features

	Conventional Sensors				OMRON
Type	Propeller	Float	Ultrasonic	Heat Wire	MEMS Heat Wire
Sensitivity	×	×	△	○	○
Response Time	×	△	△	○	○
Pressure Drop	△	△	○	○	○
Current Consumption	△	○	△	×	○
Sensing Size Element	×	×	△	△	○
Mechanical Endurance	×	×	○	○	○
	Volumetric Flow Sensor			Mass Flow Sensor	

## 3 Structure

### 3.1 Basic composition of flow sensors

OMRON flow sensors are dedicated to gas, it can be used for detecting the mass flow of various types of gases. The basic composition of flow sensors consist of a MEMS flow sensor chip that can detect the flow rate, the amplifier circuit for amplifying sensor output and the optimized flow path that is designed for each application by CAE (Computer Aided Engineering). Optimizing these three compositions is very important because gas flow is a vector volume.

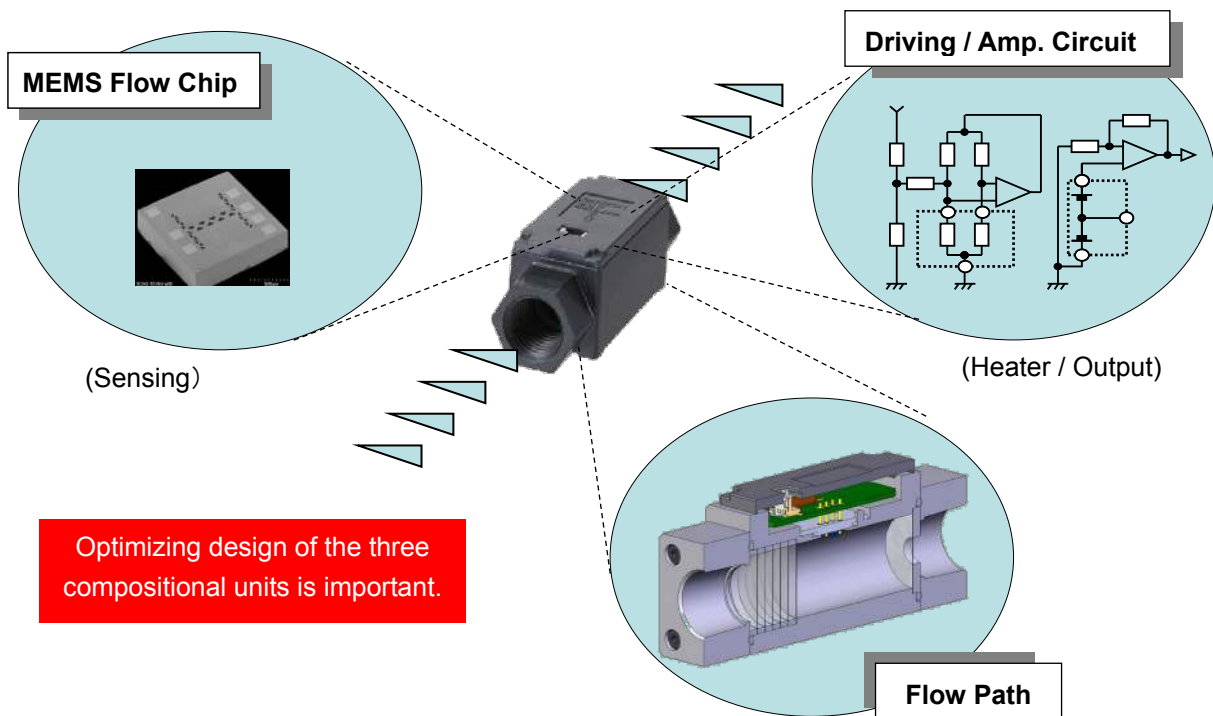
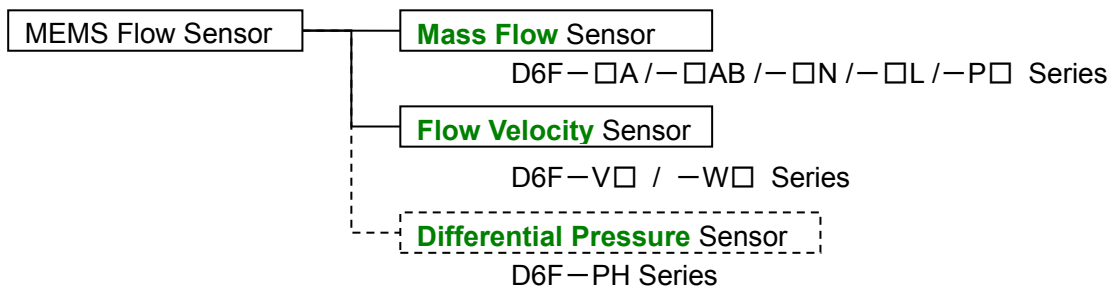

Fig. 1 Example of Internal Structure of Flow Sensor

### 3.2 Flow Sensor Product Lineup

OMRON's flow sensor lineup consists of three categories, Mass flow sensors that output a flow rate, Flow velocity sensors that output a flow velocity and Differential pressure sensors that can detect a small pressure drop.

For more information about differential pressure sensors, please refer to the application notes of MDMK-13-0196.



A flow sensor's shape and size will differ depending on the type of gas to be measured, the flow rate, and the port style. Please refer to the datasheet at the following URL for more information.

<http://www.omron.com/ecb/products/search/?cat=5&did=1&prd=mems-flow&lang=en>

Table 2 Outline Specifications of D6F series

Series Name	Medium	Flow Rate	Type	Port Style	Features
D6F-□A1	Air	1 ~ 2 lpm	Mass Flow	Bamboo Joint	Compact Size High Precision Low Flow Rate
D6F-□N2	City gas*1	1 ~ 5 lpm	Mass Flow	Rc1/4 Screw	Flammable Gas Metal Body
D6F-02L2	LPG	2 lpm	Mass Flow	Rc1/4Screw	Flammable Gas Metal Body
D6F-03A	Air	3 lpm	Mass Flow	M5 Screw	High Response Time
D6F-□A5	Air	10 ~ 50 lpm	Mass Flow	Manifold	Compact Size High Flow Rate
D6F-□A6□	Air	10 ~ 50 lpm	Mass Flow	Rc1/4 Screw NPT1/8 Screw	Compact Size High Flow Rate
D6F-□□7	City gas*1 LPG / Air	2 ~ 50 lpm	Mass Flow	Quick Joint (P10)	Quick Joint
D6F-□AB71	Air	30 ~ 70 lpm	Mass Flow	Quick Joint (P14)	Quick Joint Pulsation Reduction
D6F-P	Air	0.1 ~ 1 lpm	Mass Flow	Bamboo / Manifold	DSS*2 / Bidirectional
D6F-W	Air	1 ~ 10 m/s	Flow Velocity	—	DSS*2
D6F-V03A1	Air	3 m/s	Flow Velocity	—	Low Cost of D6F-W
D6F-PH	Air	±500 Pa	Differential Pressure	Bamboo Joint	Digital Output Differential Pressure

Note. \*1 : City Gas (Natural Gas) Standard : 13A, \*2 : DSS: Dust Segregation System



Fig. 2 D6F Series

## 4 Operating principle

### 4.1 Basic structure of MEMS flow sensor chip

The basic structure of a MEMS flow sensor chip is shown in Fig.3. This sensor chip adopts a

mass flow sensing method by using heat wire. It has a heater in the center of the chip, and the upstream thermopile (A) and the downstream thermopile (B) are located on either side of the heater, the base thermo-scope near the thermopile is made by a semiconductor process. The cavity is formed at the bottom of the heater and the thermopile arrays, so then it is possible to detect the heat from the heater effectively.

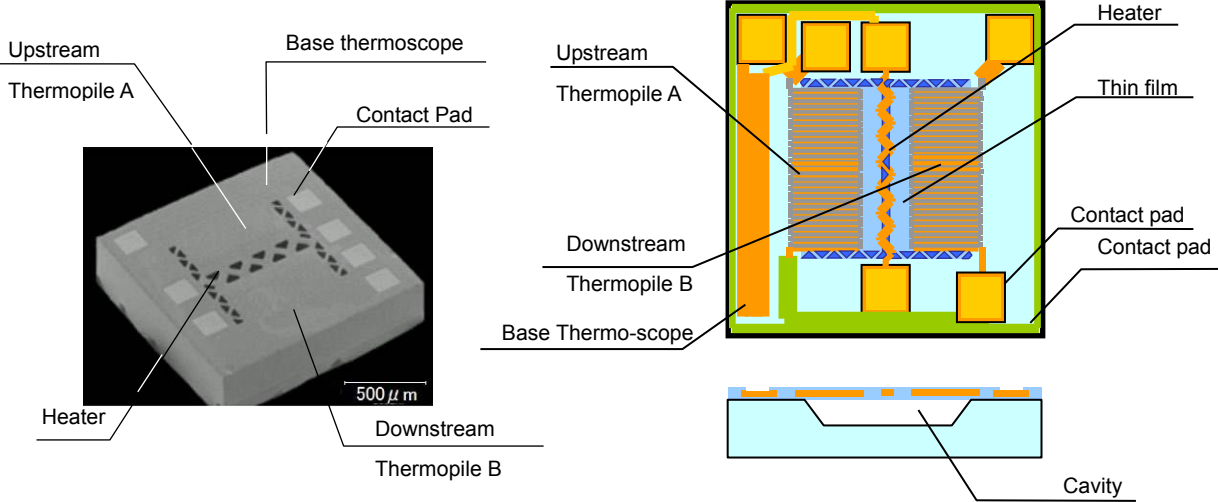

Fig.3. Flow Sensor Chip Structure

#### 4.2 Detecting principle of mass flow sensor

As shown in Fig.4, the constant current is flowing to the heater at the center of the chip and the heater becomes hot. When there is no flow, the heat distribution around the heater is symmetric, so  $V_u$  and  $V_d$  of the electromotive force from both thermopiles will be equal.

On the other hand, when there is a flow of gas on the sensor surface, the heat source is biased on the downstream side according to the flow of gas. The electromotive force of the downstream thermopile will be larger than the upstream thermopile ( $V_d > V_u$ ). The output difference between the two thermopiles is approximately proportional to the square root of the mass flow rate of the gas through the sensor surface. The output sensitivity and the mass flow rate depend on the composition ratio of the gas. Through amplification, it is possible to electronically detect the flow rate of the gas. The flow velocity sensor is adjusted so that it can output a voltage that corresponds to the flow velocity at the condition of 25°C, 101.3kPa from the mass flow rate.

When the flow direction is perpendicular to the thermopiles and heater.

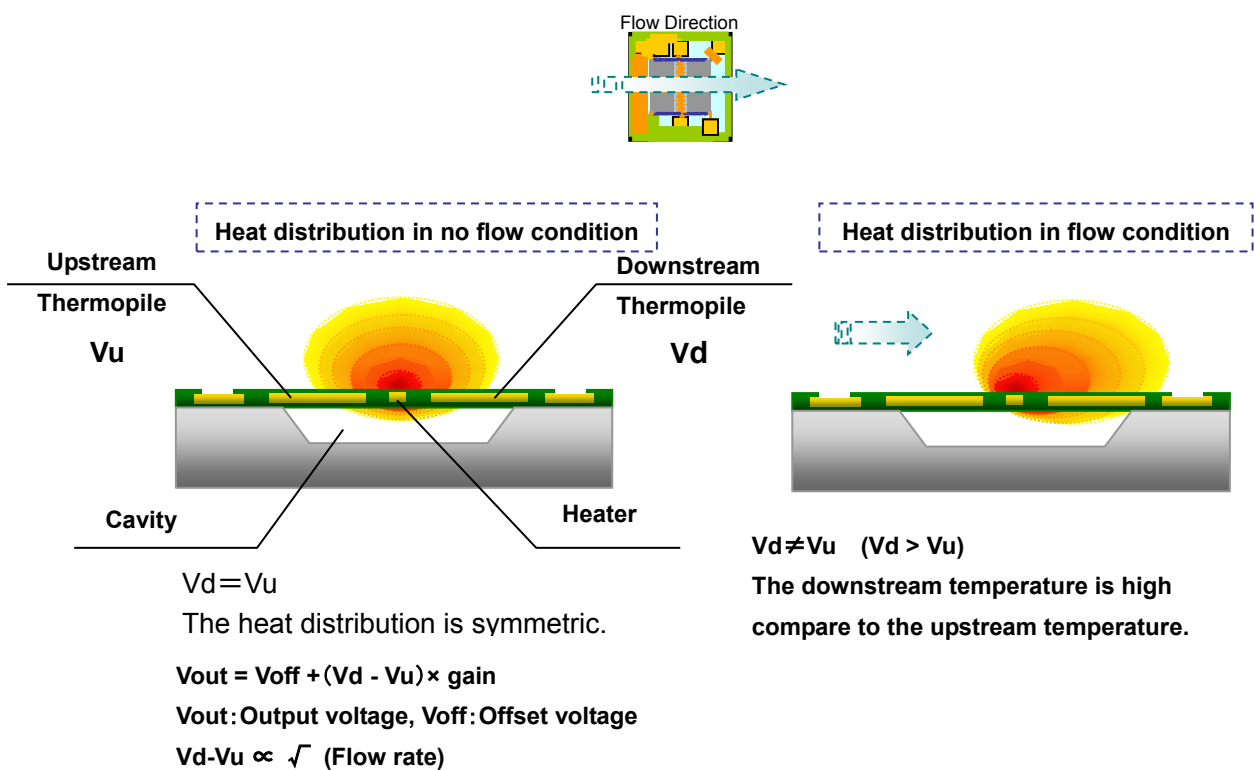

Fig4. Sensing image of mass flow sensor using heat wire

## 5 Product Features

- Mass Flow Sensing
- Wide Range Sensing Ability
- Low Power Consumption
- Ultra Small Size of MEMS Sensor

### 5.1 Characteristics of flow sensors

Table3. Representative Specifications Example of Mass Flow Sensor (D6F-□□A1-110)

Type	Type D6F-01A1-110	Type D6F-02A1-110
Flow range * 1	0~1 L/min	0~2 L/min
Application medium * 2	Air	
Port style	Bamboo Joint Max Size: $\phi$ 8.6mm , Min Size: $\phi$ 7.4mm	
Electrical connection	Connector (three wires)	
Power supply voltage	DC10.8~26.4V	
Current consumption	Max. 15mA, No load, Vcc=12~24V at 25°C	
Output signal	DC1~5V (Non-linear output, Resistive load 10k $\Omega$ )	
Accuracy	$\pm$ 3%F.S (at 25°C)	
Repeatability * 3	$\pm$ 0.3%F.S.	
Max. output voltage	DC5.7V (Resistive load 10k $\Omega$ )	
Min. output voltage	DC0V (Resistive load 10k $\Omega$ )	
Absolute maximum supply voltage	DC26.4V	
Absolute maximum output voltage	DC6V	
Case material	PPS	
Protecting structure	IP40 (IEC standard)	
Maximum permission pressure	200kPa	
Pressure drop * 3	0.42kPa	10.6kPa
Operating temperature	-10~+60°C (with no ice or no dew condensation)	
Operating humidity	35~85%RH (with no dew condensation)	
Storage temperature	-40~+80°C (with no ice or no dew condensation)	
Storage humidity	35~85%RH (with no dew condensation)	
Temperature characteristics	Within $\pm$ 3%F.S. of detected characteristics of at 25°C Over ambient temperature rang -10~+60°C	
Insulation resistance	Min. 20M $\Omega$ (DC500, between lead terminal and the base)	
Withstanding voltage	AC500V 50/60Hz for one minute between the lead terminals and the base (Leakage current is 1mA max.)	
Weight	12.8g	

\* 1. L/min (Normal) means the volumetric flow rate at 0degC, 101.3kPa. (1 atm)

\* 2. Use clean and dry gas without a dust and an oil mist.

\* 3. Reference Value (Typical value)



### 5.1.1 Detection range of flow sensors

The detection range of Flow Sensors shows the flow rate range of the gas to be detected. The lower limit voltage is the output at the lower limit and the upper limit voltage is the output at the upper limit of the detection range. This detection range is based on the condition of the volumetric flow rate at the reference state (0 °C / 101.3kPa).

The detection range of Flow Velocity Sensors (D6F-W, D6F-V) shows the flow velocity range of the gas to be detected. The lower limit voltage is the output at the lower limit and the upper limit voltage is the output at the upper limit of the detection range. This flow velocity range is based on the condition of 25 °C, 101.3kPa.

### 5.1.2 Output signal (operating characteristics)

Analog type flow sensors increase the output signal voltage with an increase in the flow rate. The output signal voltage is a non-linear and analog value of DC voltage. As a representative example of an analog type flow sensor, the output characteristic of D6F-01A1-110 is shown in Fig.5 and Table 4. This flow rate means a normal volumetric flow rate on the condition of 0°C, 101.3kPa. These values are measured on the condition of supply voltage:DC12V±0.1V, ambient temperature:25±5°C, ambient humidity: 35~75%RH.

Operating characteristics / Measurement conditions shown here will vary according to the type of sensor. Please refer to the operating characteristic information written in the product catalog or specifications corresponding to the sensor type.

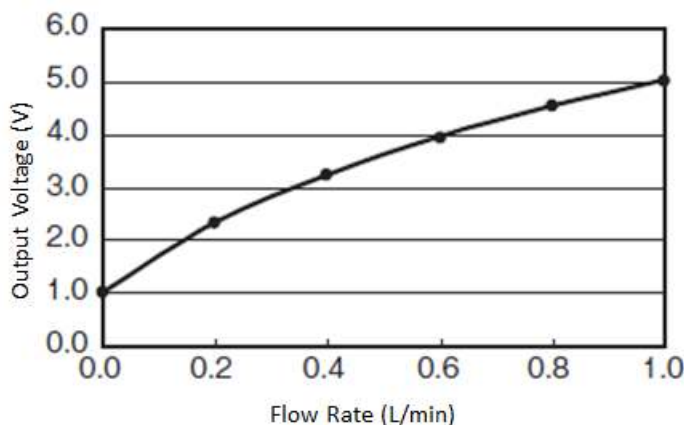

Fig.5 Output signal characteristic

Table4. Representative Example of Operating Characteristics (D6F-01A1-110)

Flow Rate(normal) (L/min)	0	0.2	0.4	0.6	0.8	1.0
Output Voltage (V)	1.00	2.31	3.21	3.93	4.51	5.00
Accuracy (V)	±0.12	±0.12	±0.12	±0.12	±0.12	±0.12

Condition: Supply voltage DC12±0.1V, Ambient temp. 25±5°C, Ambient humidity 35~75%RH

### 5.1.3 Permission pressure performance

When high pressure is impressed into a flow sensor, there is a concern about airproof degradation. So, the maximum pressure that can be impressed to a flow sensor is defined as Maximum Permission Pressure.

For example, the maximum permission pressure of D6F-01A1-110 is defined as 200kPa, this means that airproof specifications and operating characteristic specifications after the pressure test of 3 minutes at 200kPa are guaranteed.

Airproof is defined as the leak rate when a constant positive pressure is impressed to a flow sensor. For example, D6F-01A1-110 guarantees that when the positive pressure of 100kPa is impressed, the leak rate is  $1 \times 10^{-4}$  [Pa m<sup>3</sup> / s] or less.

### 5.1.4 Repeatability

OMRON flow sensors have an excellent repeatability characteristic because they have a unique flow path design which results in a stable gas flow. The repeatability is not guaranteed but a reference value.

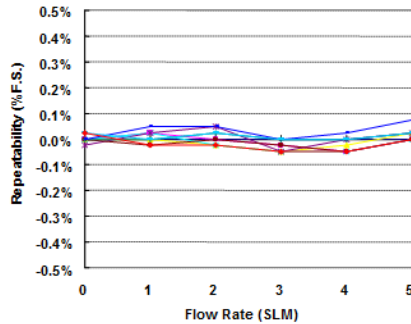

Fig.6 Repeatability characteristic



Fig.7 Flow path design

## 6 Usage of Flow Sensor

### 6.1 Electrical Connection

The load resistance (Combined resistance seen from the flow sensor side) between the Vout and GND terminals of the flow sensor should be 10kΩ or more. However, if you want to connect a resistor (R1) between the voltage output terminal (Vout) of the flow sensor and the terminal to detect the voltage (such as ADC input), please be mindful of the voltage drop by resistor (R1). In general, it is recommended that R1 is less than 1/1000 (Less than 0.1% output voltage drop) of the parallel resistance of R3 and R2 ( $R2 \parallel R3$ ). Also be sure to check the cable resistance. If the cable length is long, the resistance of the cable shall be deemed as R1.

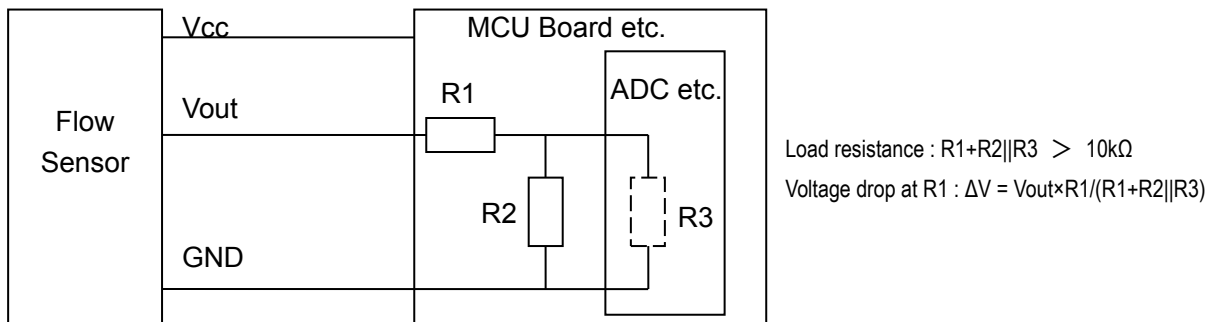

Fig.8 Load resistance of the output line

## 6.2 Port style and installation method

### 6.2.1 Screw type

Please refer to each product datasheet about the types of screw and the tightening torque. Be sure to design the airproof structure by using a seal tape. When installing this type, the specified taper thread for piping should be used. In addition, please set to 5N·m or less of the tightening torque. If the tightening torque goes beyond the limit, there is risk that the sensor will crack and/or gas leakage occurs. Please put an appropriate amount of sealant on the screw. Do not paint a sealant on two screw threads from the tip of the screw.

### 6.2.2 Quick fastener type

A quick fastener type for connecting a pipe with a flange is available. The quick fastener type can be attached and detached by hand (no tools necessary). Currently, there are two kinds of quick fastener types that have P14 and P10 shape. Below shows the outline dimensions of quick fastener type of P14 and P10. Please refer to the respective product datasheet to determine which type of quick fastener is recommended.

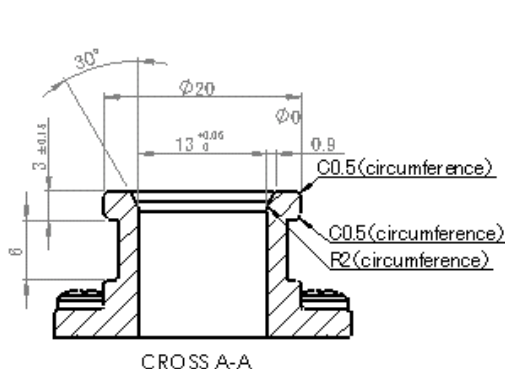

Fig.9 Quick fastener P10 Outline Dimensions

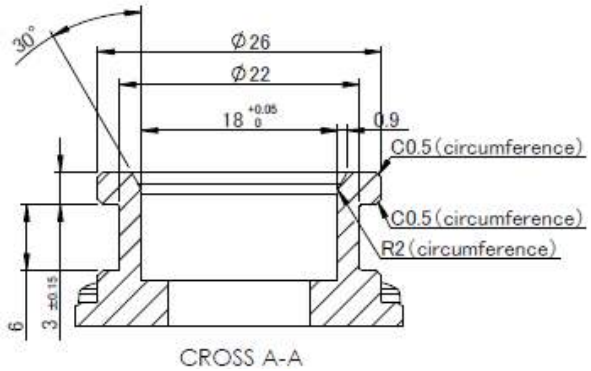

Fig.10 Quick fastener P14 Outline Dimensions

<List of quick fastener type in Omron >

D6F-□A7 : Quick fastener type P10

D6F-□N7 : Quick fastener type P10

D6F-□L7 : Quick fastener type P10

D6F-□AB71 : Quick fastener type P14

### 6.2.3 Manifold mount type

The D6F-□A5 and D6F-P series have a manifold mount type. A manifold mount type, even if there is no space in the straight pipe direction can be installed in a small space. Below shows the dimensions of the bottom view and the connection example of the manifold mount type D6F-□A5.

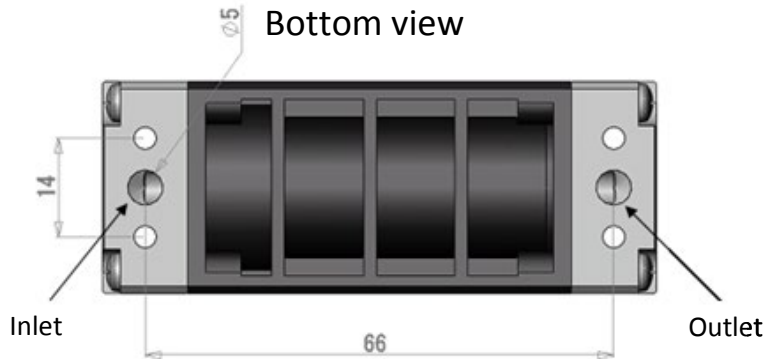

Fig.11 D6F-□A5 Bottom view

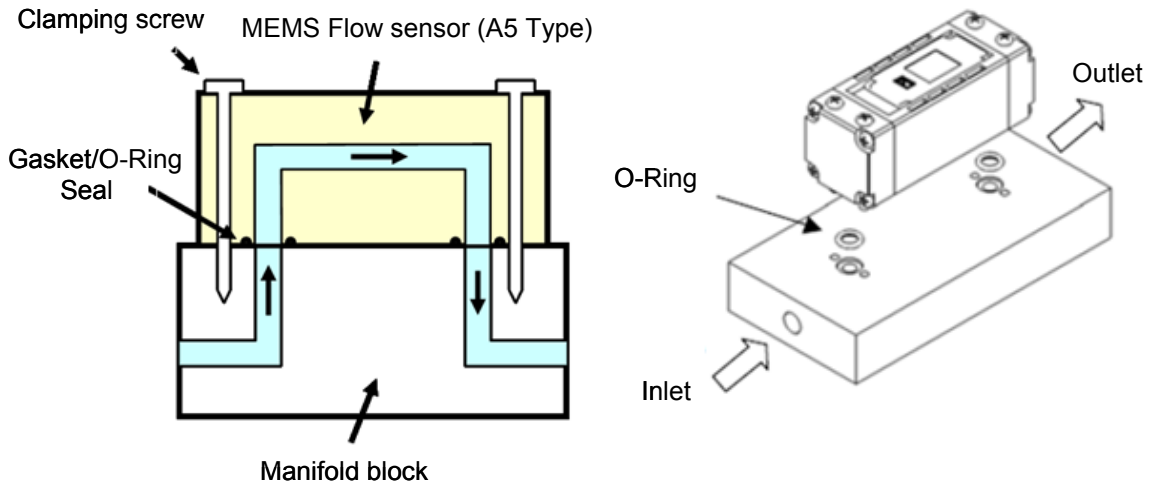

Fig.12 Connection example for manifold mount type

Table 5 Recommended O-ring type

Product Type	Port Style	Recommended O-Ring Type		Reference O-Ring Type	
		Designation		Designation	
D6F-□□A5	Manifold	Designation	JIS B 2401 P5	Designation	ISO 3601-1 A0048G
		Size	Inner diameter :4.80±0.15mm Cross section :1.90±0.08mm	Size	Inner diameter : 4.87±0.15mm Cross section : 1.80±0.08mm
		Material	NBR (for reference)	Material	NBR (for reference)
D6F-P□□□□AM	Manifold	Designation	JIS B 2401 P4	Designation	ISO 3601-1 A0037G
		Size	Inner diameter : 3.80±0.14mm Cross section : 1.90±0.08mm	Size	Inner diameter : 3.75±0.14mm Cross section : 1.80±0.08mm
		Material	NBR (for reference)	Material	NBR (for reference)

## 6.2.4 Bamboo type

A bamboo type is used in a state where the urethane tube or others is inserted. Inserting is very easy. It can be done by hand (no tools necessary). In addition, there is the benefit that the variation due to human error is less likely to occur. Both the D6F-□A1 series and D6F-P series are available in bamboo type. In the case of the D6F-□A1 series, the inner diameter of the pipe is  $\phi 4\text{mm}$ , maximum outer diameter is  $\phi 8.6\text{mm}$ , and minimum outer diameter is  $\phi 7.4\text{mm}$ . In the case of the D6F-P series, the maximum outer diameter of the pipe is  $\phi 4.9\text{mm}$ . When using a bamboo type, be sure to design an airproof structure. If leakage occurs from the joint, a correct measurement cannot be achieved.

Please note that don't turn the pipe to the right when connecting the pipe to the bamboo joint. In case the pipe is turned to the right, the internal part of the bamboo joint might be worked loose and worked off.

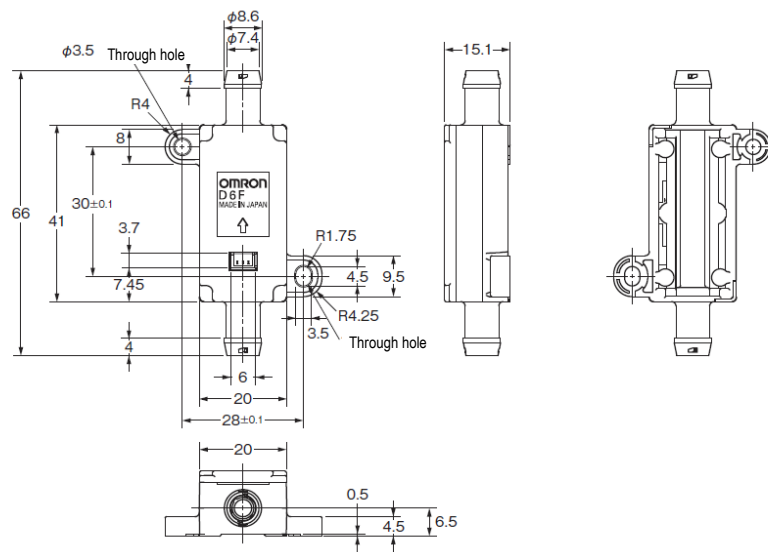

Fig.13 D6F-01A1-110 Outline Dimensions

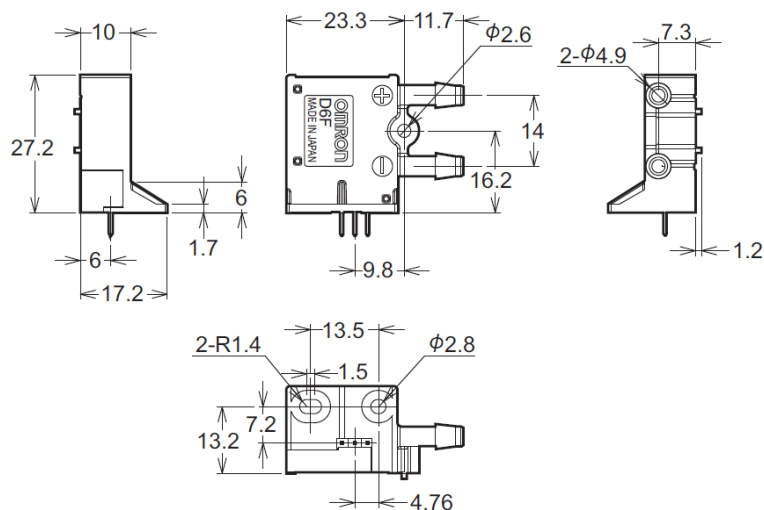

Fig.14 D6F-P0010A1 Outline Dimensions

## 6.3 Attention for piping and connection

### 6.3.1 Cleanup of the inflow gas

The fluid should be dry and clean without dust and oil mist. Dust and oil mist may cause characteristic changes and failures. A filter or a mist separator should be installed upstream of the pipe. Foreign substances into the pipe can cause failures. Please be careful when handling so that the foreign substances do not enter the pipe after removing the sensor from the packaging bag.

### 6.3.2 Stabilization

When using a diaphragm pump, pulsation can occur. This can adversely affect the measurement accuracy of the flow rate. Some models in OMRON's flow sensor lineup have an internal system for reducing the influence of pulsation, but it may not completely remove the effect of pulsation. If the effect of pulsation is a concern, please use countermeasures to reduce pulsation, such as changing to a pump less likely to cause pulsation or establish a buffer tank and/or an orifice in the flow path.

### 6.3.3 Measurement of high flow

By making a bypass flow path by pulling some gas from the main flow path at a high flow rate, it is possible to measure the gas flow rate of the whole piping by measuring the flow rate in the bypass section. The differential pressure between inflow and outflow to the bypass section is generated by making a resistor, such as an orifice in main flow path. Gas will flow into the bypass flow path by this differential pressure.

An example of a bypass flow connection and differential pressure calculation to be generated are shown in Fig. 15 and 16.

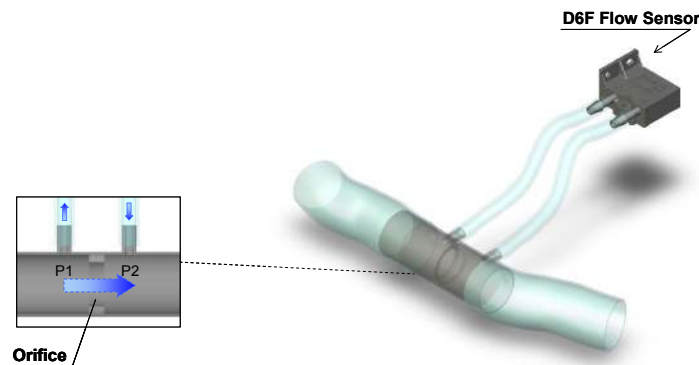

Fig.15 Example of Bypass Flow Connection

$$\Delta P = \frac{1}{A_o^2} \cdot \frac{C^2 \rho}{2} \cdot V^2$$

**AP** : Differential pressure  
**Ao** : Opening diameter of the orifice  
**C** : Runoff coefficient (0.6~0.8)  
**P** : Density  
**V** : The volume flow in main flow channel

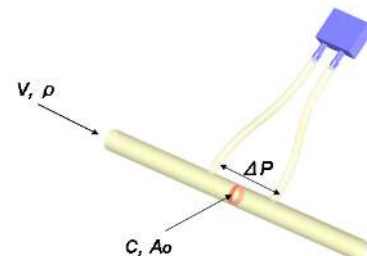

Fig.16 Example of differential pressure calculation

---

#### 6.3.4 Consideration of the laminar flow

If a pipe has sufficient straight section before and after the sensor, the fluid inside the pipe will achieve laminar flow. However, the fluid becomes turbulent when there is not enough straight section of pipe. In general, the following requirements are needed in order to achieve laminar airflow inside a pipe.

- The sensor inlet side requires a length of 10 times the internal orifice diameter of straight pipe.
- The sensor outlet side requires a length of 5 times the internal of orifice diameter of straight pipe.

Furthermore, it is possible to reduce the influence of turbulence with regards to mounting the sensor.

1. Against gas flow coming into the sensor

Put a guide to the sensor inlet in order to stabilize the gas flow. Flow rate is stabilized with a long and straight guide, but you may be able to measure by attaching a guide of about 5mm.

2. Against gas flow exiting from the sensor

By putting a buffer tank and/or by putting the orifice at the outlet of the buffer tank, it makes squeeze the flow rate.

3. Put the jig (rotation direction in particular) so that the sensor direction can be fixed.

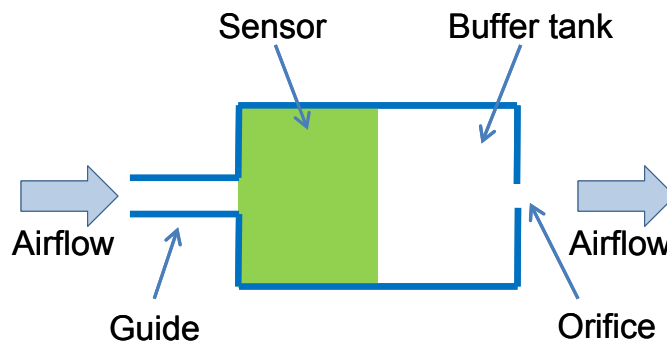

Fig.17 Example of the gas flow stabilization

#### 6.4 The influence of environment

Flow sensors are affected by an influence of ambient environment and use conditions, which can lead to changing output characteristics. Please be sure to check the output characteristics in actual conditions before use, and also check the product specifications regarding characteristics and use conditions that are guaranteed.

In this paragraph, the characteristics in the conditions of which are not defined in the product specifications are described for customer evaluation. Please understand that it is not guaranteed but only for reference.

### 6.4.1 Temperature characteristics

Basic characteristics of OMRON's flow sensors specify the output characteristics and the accuracy at the conditions of  $25\pm 5^{\circ}\text{C}$  but the flow sensor has temperature characteristics. If the ambient temperature is changed, the output characteristics of the flow sensor will vary. Variation due to temperature change is expressed in %FS as the maximum amount of variation within the operating temperature range defined in specifications, which is represented based on the output at  $25^{\circ}\text{C}$ . This variation counts towards the precision to be defined as the basic specifications. For example, when using in  $-10 \sim 60^{\circ}\text{C}$  ambient temperature, the variation of D6F-01A1-110 will be  $\pm 3\%$ F.S. of  $25^{\circ}\text{C}$  characteristics, which means that there is a case where the variation of  $\pm 0.12\text{V}$  occurs as a flow sensor voltage output. As a general example, Fig.18 shows the output variation of D6F-01A1-110 from the characteristics at  $25^{\circ}\text{C}$ .

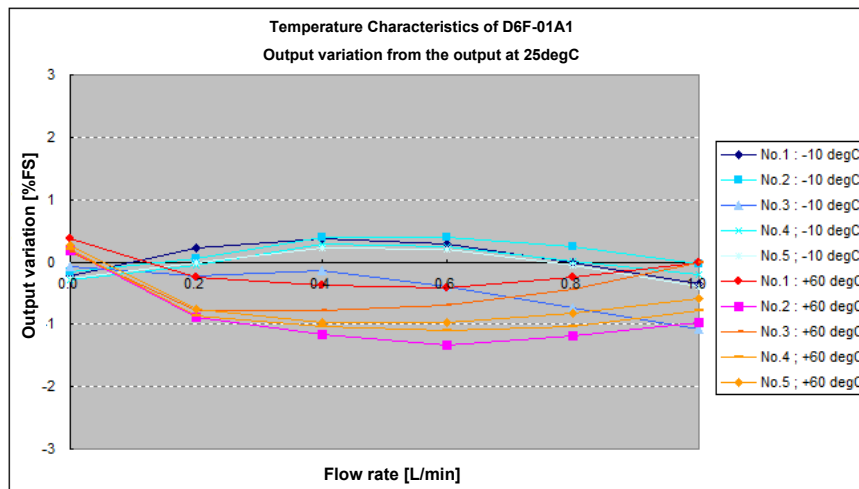

Fig 18. Temperature characteristic of D6F-01A1-110

### 6.4.2 The influence of dust

If dust is deposited on the flow channel and the sensor chip, it changes the flow sensor's output characteristics. Therefore, it is recommended a filter be used with the sensor depending on the gas that is used.



### 6.4.3 The influence of pressure and temperature

OMRON's flow sensors can measure a mass flow rate. In order to comply with the combined gas law, even in the same gas volume flow, the mass flow rate becomes low when the pressure is low or the temperature is high. On the other hand, the mass flow rate becomes high when the pressure is high or the temperature is low. For example, when measuring the same volumetric flow rate at a high altitude (or high temperature) and a low altitude (or low temperature), the mass flow rate at a high altitude (high temperature) is smaller than that at a low altitude (or low temperature).

Equation of state of ideal gas  $PV = nRT$

Boyle-Charle's law  $\frac{PV}{T} = \frac{P'V'}{T'}$

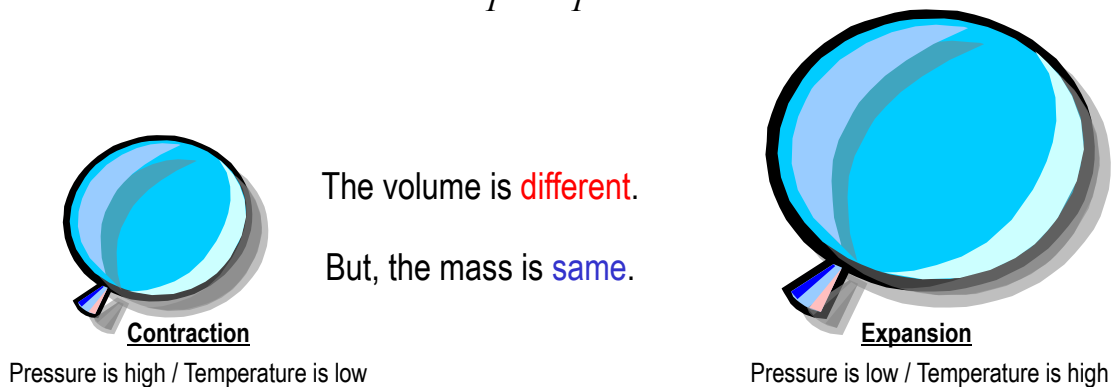

Fig.19 Influence of pressure and temperature

### 6.4.4 The influence of the mounting direction

The mounting direction can influence the output characteristics of a flow sensor. These characteristics can vary slightly due to the heat distribution of the flow sensor chip, as shown in Fig.20. The variation is  $\pm 1\%$ FS or more in actual measurement. OMRON recommends a horizontal installation in product specifications for this reason. It should be considered that there are some characteristics variations with vertical installation.

The amount of variation depends on the actual sensor type.

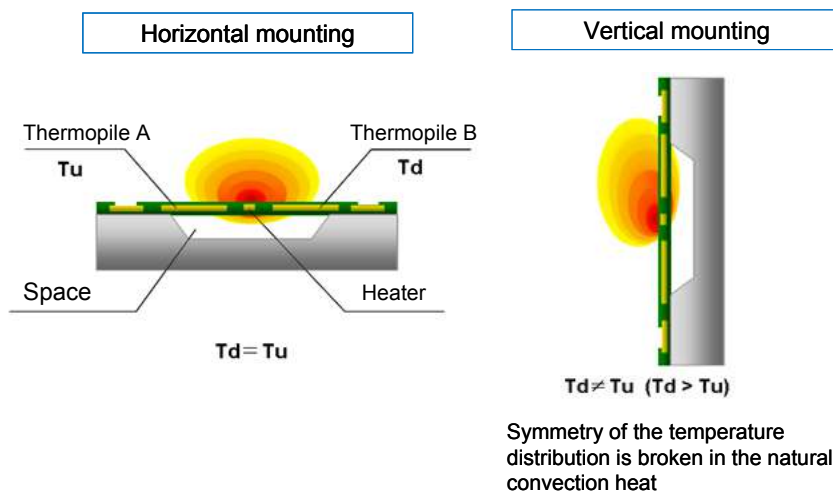

Fig.20 Influence of mounting direction of the sensor chip

#### 6.4.5 Output changes in various gases

By the measurement principle of flow sensors, the output characteristics are affected by the physical properties of the medium involved in the heat conduction. For example, constant pressure specific heat, thermal conductivity, density and viscosity coefficient will affect the sensitivity of the sensor. This means that the output characteristics depend on the type of gases. Application media to be measured are specified for respective models. When performing the measurement of gas flow that is not stated in the specifications, the output characteristics are different from the output characteristics in the specifications. Please be careful to check the output characteristics in use. Fig.21 shows a comparison of the output characteristics of the D6F-01A1-110 for He and Air.

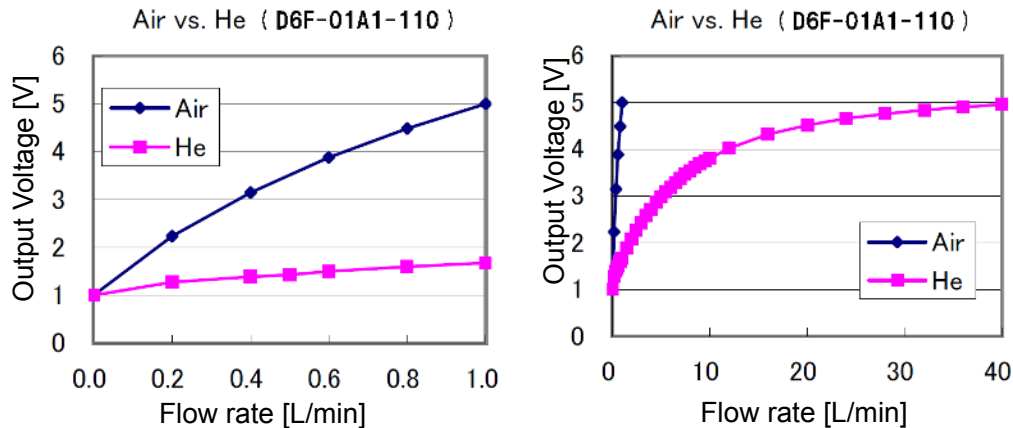

Fig .21 Output characteristics measured value of Air and He in D6F-01A1-110  
(Left graph : 0 to 1 L/min range , Right graph : 0 to 40L/min range)

#### 6.4.6 The behavior in over flow rate range

OMRON's flow sensors define the assumed flow rate range (wind speed range in air flow sensor) in each type. Even if the flow rate is below the minimum or the flow rate is over the maximum, there is little adverse effect on the sensor itself. If the flow rate exceeds the upper limit of the specified flow range, the output is gradually increased beyond the upper limit of the output signal, and then saturated at a constant output voltage. Similarly in the case where the flow rate is below the lower limit of the flow rate range, the output signal is reduced beyond the lower limit, and then saturated at a constant output voltage. Output characteristics that exceed the defined flow rate range are not covered under warranty.

#### 6.4.7 The influence of humidity

Humidity of the fluid can have an adverse effect on the measurement accuracy in mass flow sensors. Please use dry gas taking into account that the mass increases if the humidity is high.

## 6.5 Application example

Table 6 Application Example

Category	Application	Usage
Air Conditioner	HVAC / VAV Air Filter	Clogged Filter Detection Leak Detection Flow Rate Detection
Burning Control	House Hold Fuel Cell Boiler AMR (Automatic Meter Reading) AMI (Advanced Metering Infrastructure)	Control for Gas Mixing Measurement of Gas Consumption
Medical Equipments	Oxygen Concentration Device Respirator Anesthetic Apparatus Home Medical Equipments	Breathing Quantity Monitor Control for Gas Supply Measurement of Gas Consumption
Others	Chemical Analysis Equipments Welding Machine Air Filter Cooling Fan	Chemical Analyzer Measurement of Gas Consumption Flow Rate Detection Clogged Filter Detection Leak Detection

## 7 Glossary

- **MEMS**

The MEMS, which stands for "Micro Electro Mechanical Systems", is a generic term for devices that consist of micromechanical component parts, sensors, actuators, and electrical circuits that are integrated on a silicon substrate, glass substrate or organic material and are fabricated by semiconductor integrated circuit technology.

- **%F.S. and %RD**

%FS is the accuracy for the output full scale in the detection range of flow rate (flow velocity) and %RD is the accuracy for the output reading. In the case of %F.S. prescript, the output error is constant for all detection ranges because the output full-scale is constant. On the other hand, in the case of %RD prescript, the output error depends on the reading value.

Herein, the output full scale is the difference between the minimum output value and the maximum output value in flow rate detection range and the output reading is the difference between the minimum output value and the output value at a certain flow rate.

Also temperature characteristics may be expressed as the difference between the characteristics of a specific temperature by %RD and %F.S.

### %F.S.

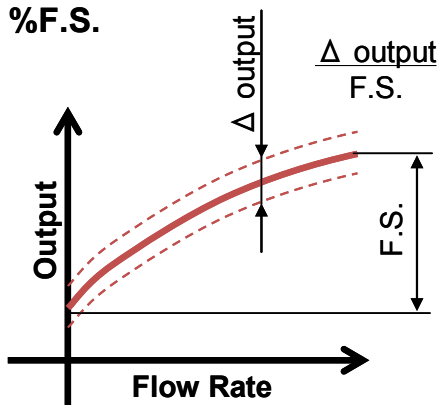

<%F.S. prescript>

An accuracy prescript for the output full scale

Ex) 1-5V output type @ +/- 3%F.S.

Not dependent on output voltage

$\pm 3\%F.S. = \pm 3\% \times (5V - 1V) = \pm 0.12V$

Fig. 22 Accuracy in %F.S. prescript

### %RD

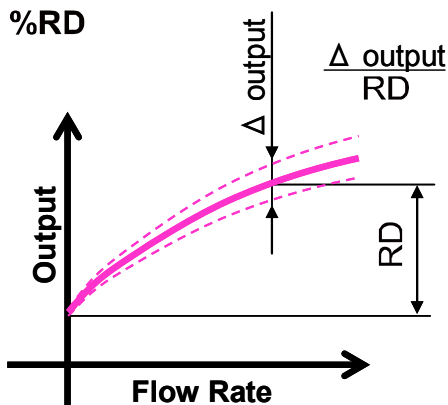

<%RD prescript>

An accuracy prescript for a reading value

Ex) 1-5V output type @ +/- 3%RD

Output voltage is 3V at a certain flow rate

$\pm 3\%RD = \pm 3\% \times (3V - 1V) = \pm 0.06V$

Fig. 23 Accuracy in %RD prescript

---

- **Volumetric flow rate and Mass flow rate**

The volumetric flow rate is the volume of gas flowing per unit time. It is proportional to the temperature, which is inversely proportional to the pressure. It is described as  $\text{m}^3/\text{s}$ ,  $\text{m}^3/\text{min}$ ,  $\text{L}/\text{s}$ , or  $\text{L}/\text{min}$  in case of SI unit. The volume of gas is influenced by the pressure and the temperature, so then the condition of the pressure and the temperature should be considered in case of the volumetric flow rate.

On the other hand, the mass flow rate is the mass of gas flowing per unit time. It does not depend on the temperature and the pressure. It is described as  $\text{kg}/\text{s}$ ,  $\text{kg}/\text{min}$  in case of SI unit. OMRON's MEMS flow sensor will output an equivalent value with the mass flow rate.

- **Normal Volumetric Flow Rate and Standard Volumetric Flow Rate**

To define this mass flow rate, it is common to express as the volumetric flow rate at the conditions which defines the pressure and temperature. The condition of the pressure and temperature are 1atm (101.3kPa) and 0 degree C. Under this condition, the volumetric flow rate value is expressed as NLM (Normal Liters per Minute) or SLM (Standard Liters per Minute). Each company has each condition of this pressure and temperature and there is no rule in particular. Please be sure to check the standard condition of the product before use.

---

## 8 WARRANTY AND LIMITED LIABILITY

Thank you for your usage of products of Omron Corporation (“Omron”). Without any special agreements, this Terms and Conditions shall apply to all transactions regardless of who sells. Place an order, accepting this Terms and Conditions.

### 8.1 DEFINITIONS

The following terms used herein have following meaning.

- (1) Omron Products; Electronic components sold by Omron
- (2) Catalogues; Any and all catalogues (including the Components Catalogue), specifications, instructions and manuals relating to Omron Products, including electronically provided data.
- (3) Conditions; Use conditions, rating, performance, operating environment, handling procedure, precautions and/or prohibited use of Omron Products described in the Catalogues.
- (4) User Application(s); Application of Omron Products by a customer, including but not limited to embedding Omron Products into customer’s components, electronic circuit boards, devices, equipments or systems
- (5) Fitness; (a)performance, (b) no infringement of intellectual property of third party, (c) compliance with laws and regulations and (d)conformity to various standards by Omron Products in User Applications.

### 8.2 NOTE ABOUT DESCRIPTIONS

Please understand following as to contents of the Catalogues.

- (1) Rating and performance is tested separately. Combined conditions are not warranted.
- (2) Reference data is intended to be used just for reference. Omron does NOT warrant that the Omron Product can work properly in the range of reference data.
- (3) Examples are intended for reference. Omron does not warrant the Fitness in usage of the examples.
- (4) Omron may discontinue Omron Products or change specifications of them because of improvements or other reasons.

### 8.3 NOTE ABOUT USE

Please understand followings as to your adoption and use of Omron Products

- (1) Please use the product in conformance to the Conditions, including rating and performance.
- (2) Please confirm the Fitness and decide whether or not Omron Products are able to be adopted in the User Application.
- (3) Omron will not warrant any items in 1.(5) (a) to (d) of User Application nor the Fitness.
- (4) If you use Omron Products in the application below, please ensure followings; (i) allowance in aspect of rating and performance, (ii) safety design which can minimize danger of the Application when the product does not work properly and (iii) periodical maintenance of the product and the Application.
  - (a) Applications requiring safety, including, without limitation, nuclear control facilities, combustion facilities, aerospace and aviation facilities, railroad facilities, elevating facilities, amusement facilities, medical facilities, safety devices or other applications which has possibility to influence lives or bodies
  - (b) Applications requiring high reliability, including, without limitation, supplying systems of gas, water and electric power and applications handling right, title, ownership or property, such as payment systems

- 
- (c) Applications in a harsh condition or environment, including, without limitation, outdoor facilities, facilities with potential of chemical contamination or electromagnetic interference, facilities with vibration or impact and facilities on continual operation for a long period
  - (d) Applications under conditions or environment which are not described in this specification
- (5) Omron Products shown in this catalogue are not intended to be used in automotive applications (including two wheel vehicles). Please DO NOT use the Omron Products in the automotive application.
- (6) THE PRODUCTS CONTAINED IN THIS CATALOG ARE NOT SAFETY RATED. THEY ARE NOT DESIGNED OR RATED FOR ENSURING SAFETY OF PERSONS, AND SHOULD NOT BE RELIED UPON AS A SAFETY COMPONENT OR PROTECTIVE DEVICE FOR SUCH PURPOSES. Please refer to separate catalogs for OMRON's safety rated products.

#### **8.4 WARRANTY**

Warranty of Omron Products is subject to followings.

- (1) Warranty Period; One year after your purchase
- (2) Warranty; Omron will provide, free of charge, replacements of the same number of malfunctioning products
- (3) Exceptions; This warranty does not cover malfunctions caused by any of the following.
  - (a) Usage in the manner other than its original purpose
  - (b) Usage out of the Conditions
  - (c) Cause which could not be foreseen by the level of science and technology at the time of shipment of the product
  - (d) Cause outside Omron or Omron Products, including force majeure such as disasters

#### **8.5 LIMITATION ON LIABILITY**

THE WARRANTY DESCRIBED IN THIS "TERMS AND CONDITIONS" IS A WHOLE AND SOLE LIABILITY FOR OMRON PRODUCTS. THERE ARE NO OTHER WARRANTIES, EXPRESSED OR IMPLIED. OMRON AND DISTRIBUTORS ARE NOT LIABLE FOR ANY DAMAGES ARISEN FROM OR RELATING TO OMRON PRODUCTS.

#### **8.6 PROGRAMMABLE PRODUCTS**

OMRON shall not be responsible for the user's programming of a programmable product, or any consequence thereof.

#### **8.7 EXPORT CONTROLS**

Buyer shall comply with all applicable laws and regulations of Japan and/or other related countries at the time of export or provision to non-citizens of Omron Products or their technical information.

EC200E

Please check each region's Terms & Conditions by region website.

---

## **OMRON Corporation**

**Electronic and Mechanical Components Company**

### **Regional Contact**

#### **Americas**

<https://www.components.omron.com/>

#### **Asia-Pacific**

<https://ecb.omron.com.sg/>

#### **Korea**

<https://www.omron-ecb.co.kr/>

#### **Europe**

<http://components.omron.eu/>

#### **China**

<https://www.ecb.omron.com.cn/>

#### **Japan**

<https://www.omron.co.jp/ecb/>