

- NOTES:
1. MATERIAL: ZINC
 2. FINISH: NON-CONDUCTIVE BLACK FINISH
OUTSIDE SURFACES ONLY
 3. THIS PART MATES WITH 71425-3001 AND 73796-2***
 4. DULL NICKEL OVER COPPER FLASH.
 5. LOGO TO BE ON A 0.25(010) RAISED PAD.

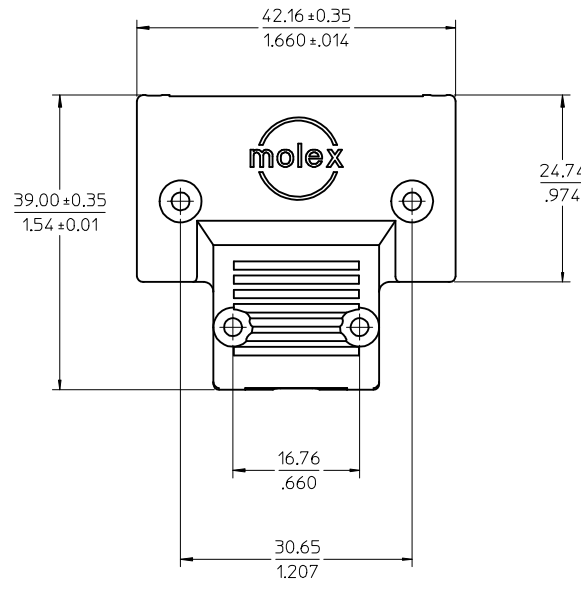

MATERIAL NUMBER	FINISH	WIRE AWG	LOGO
73796-2018	NICKEL (SEE NOTE 4)	28 AWG	MOLEX
73796-2015	BLACK (SEE NOTE 2)	28 AWG	MOLEX
73796-2012	BLACK (SEE NOTE 2)	30 AWG	HP
73796-2009	BLACK (SEE NOTE 2)	30 AWG	NO LOGO
73796-2006	NICKEL (SEE NOTE 4)	30 AWG	MOLEX
73796-2003	BLACK (SEE NOTE 2)	30 AWG	MOLEX
73796-2027	BLACK (SEE NOTE 2)	34 AWG	MOLEX
73796-2030	NICKEL (SEE NOTE 4)	34 AWG	MOLEX

REVISED EC NO: UCP2004-1796 DRWN: RL WHITE 2004/08/10 CHKD: BBARKER 2004/08/10 APPR: SMILLER 2004/08/18	QUALITY SYMBOLS	GENERAL TOLERANCES (UNLESS SPECIFIED)	SCALE 2:1	DESIGN UNITS METRIC	THIRD ANGLE PROJECTION	REVISE ON CAD ONLY															
	▼ - 0 ∇ - 0	<table border="1"> <thead> <tr> <th></th> <th>mm</th> <th>INCH</th> </tr> </thead> <tbody> <tr> <td>4 PLACES</td> <td>± ---</td> <td>± ---</td> </tr> <tr> <td>3 PLACES</td> <td>± ---</td> <td>± .005</td> </tr> <tr> <td>2 PLACES</td> <td>± 0.13</td> <td>± .010</td> </tr> <tr> <td>1 PLACE</td> <td>± 0.25</td> <td>± ---</td> </tr> </tbody> </table>		mm	INCH	4 PLACES	± ---	± ---	3 PLACES	± ---	± .005	2 PLACES	± 0.13	± .010	1 PLACE	± 0.25	± ---	DIMENSION STYLE MM/IN	TITLE VHDCI UPPER DIE CAST SHELL		
			mm	INCH																	
		4 PLACES	± ---	± ---																	
3 PLACES	± ---	± .005																			
2 PLACES	± 0.13	± .010																			
1 PLACE	± 0.25	± ---																			
DRAFT WHERE APPLICABLE MUST REMAIN WITHIN DIMENSIONS	DRAWN BY KSTILES DATE 10/11/2002 CHECKED BY KSTILES DATE 10/14/2002 APPROVED BY MBANAKIS DATE 10/18/2002	MOLEX INCORPORATED SEE CHART SD-73796-003																			
			MATERIAL NO. SHEET NO. THIS DRAWING CONTAINS INFORMATION THAT IS PROPRIETARY TO MOLEX INCORPORATED AND SHOULD NOT BE USED WITHOUT WRITTEN PERMISSION		1 OF 1																

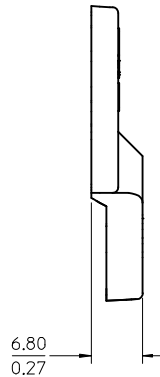
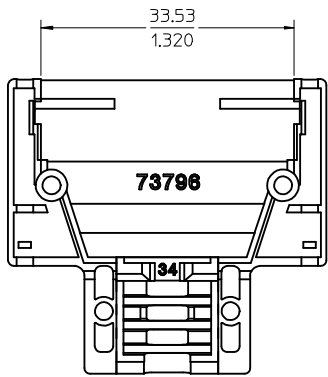
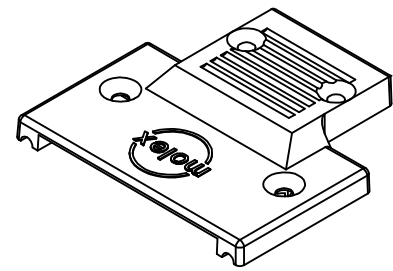
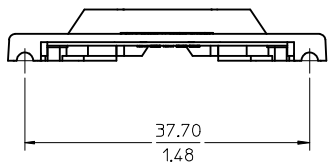

- NOTES:
 1. MATERIAL: ZINC
 2. FINISH: NON-CONDUCTIVE BLACK FINISH
 OUTSIDE SURFACES ONLY
 3. THIS PART MATES WITH 71425-3001 AND 73796-2***
 4. DULL NICKEL OVER COPPER FLASH.
 5. LOGO TO BE ON A 0.25(010) RAISED PAD.

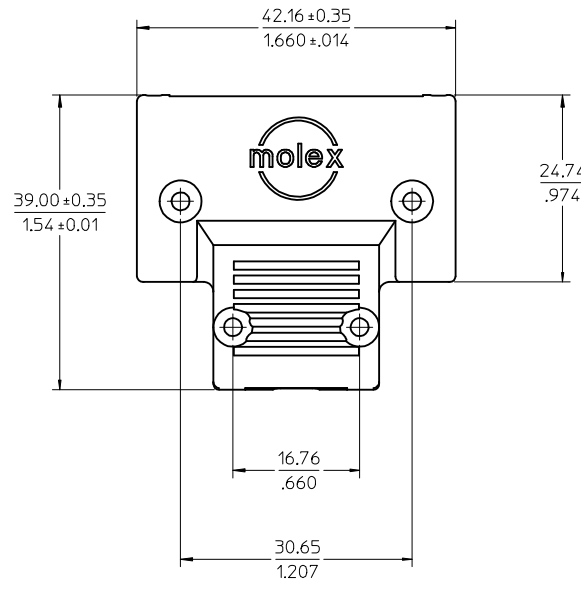
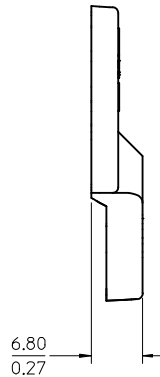
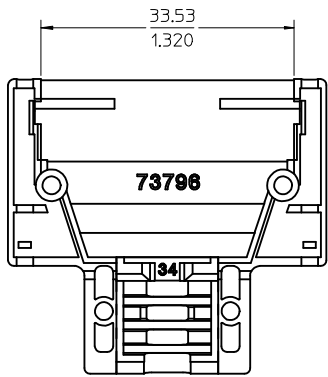

MATERIAL NUMBER	FINISH	WIRE AWG	LOGO
73796-2018	NICKEL (SEE NOTE 4)	28 AWG	MOLEX
73796-2015	BLACK (SEE NOTE 2)	28 AWG	MOLEX
73796-2012	BLACK (SEE NOTE 2)	30 AWG	HP
73796-2009	BLACK (SEE NOTE 2)	30 AWG	NO LOGO
73796-2006	NICKEL (SEE NOTE 4)	30 AWG	MOLEX
73796-2003	BLACK (SEE NOTE 2)	30 AWG	MOLEX
73796-2027	BLACK (SEE NOTE 2)	34 AWG	MOLEX
73796-2030	NICKEL (SEE NOTE 4)	34 AWG	MOLEX

REVISED EC NO: UCP2004-1796 DRWN: RL WHITE 2004/08/10 CHKD: BBARKER 2004/08/10 APPR: SMILLER 2004/08/18	DESCRIPTION REV	QUALITY SYMBOLS	GENERAL TOLERANCES (UNLESS SPECIFIED)	SCALE 2:1	DESIGN UNITS METRIC	THIRD ANGLE PROJECTION	REVISE ON CAD ONLY
		▼ - 0 ∇ - 0	mm INCH 4 PLACES ± --- ± --- 3 PLACES ± --- ± .005 2 PLACES ± 0.13 ± .010 1 PLACE ± 0.25 ± --- ANGULAR ± 1/2°	DIMENSION STYLE MM/IN		TITLE	
		DRAFT WHERE APPLICABLE	DRAWN BY DATE KSTILES 10/11/2002 CHECKED BY DATE KSTILES 10/14/2002 APPROVED BY DATE MBANAKIS 10/18/2002	MOLEX INCORPORATED SEE CHART SD-73796-003		SHEET NO. 1 OF 1	
		MUST REMAIN WITHIN DIMENSIONS	THIS DRAWING CONTAINS INFORMATION THAT IS PROPRIETARY TO MOLEX INCORPORATED AND SHOULD NOT BE USED WITHOUT WRITTEN PERMISSION				