

PART NUMBER	REVISION	DESCRIPTION	FEED TYPE
2150067-1	D	FINE CRIMP HEIGHT ADJUST	MECHANICAL
2150067-2	D	FINE CRIMP HEIGHT ADJUST	PNEUMATIC
7-2150067-1	D	MECHANICAL AND CRIMP TOOLING KIT	MECHANICAL
7-2150067-2	D	PNEUMATIC AND CRIMP TOOLING KIT	PNEUMATIC
7-2150067-7	A	CRIMP TOOLING KIT	-

ATLANTIC VERSION TERMINATOR INTERFACE ADAPTER



APPLICATOR DATA		
CRIMP	SIZE	TYPE
WIRE	1.78 mm [.070]	F
INSUL	3.05 mm [.120]	O

APPLICATOR INSTRUCTIONS 408-35043

TERMINAL DATA: TE TERMINAL		TE CRIMP SPECIFICATION	
TERMINAL NAME: .250 SERIES AUTOMOTIVE POSITIVE LOCK RECEP			
WIRE STRIP LENGTH		INSULATION DIAMETER RANGE	
4.20-5.20 mm [.165-.205 IN]		∅1.50-2.40 mm [.059-.094 IN]	
TERMINAL APPLICATION SPECIFICATION	114-5060		
TERMINALS APPLIED			
TE TERMINAL	TE TERMINAL	TE TERMINAL	TE TERMINAL
170452-1	170452-2	368037-2	

WIRE SIZE	CRIMP HEIGHT mm [INCH]	CRIMP HEIGHT REFERENCE SETTING
0.50mm2	1.36 +/- 0.05 [.054 +/- .002]	5.4
0.30mm2	1.27 +/- 0.05 [.050 +/- .002]	6.4

- 1 RECOMMENDED SPARE PARTS
- 2 REFER TO SUPPLIED INSTRUCTION SHEET FOR CLEANING, LUBRICATION AND STORAGE OF APPLICATOR.
- 3 APPLY PART NUMBER 2-23419-6 LOCTITE TO THREADS OF ITEM 242. APPLY PART NUMBER 1-23419-5 LOCTITE TO THREADS OF ITEM 50.
- 4 CRIMP HEIGHT REFERENCE SETTING WAS THE SETTING USED WHEN THE APPLICATOR WAS QUALIFIED AT THE FACTORY. ADJUSTMENT MAY BE NECESSARY WHEN RUNNING APPLICATOR IN THE FIELD.
- 5. UNLESS SPECIFIED OTHERWISE TORQUE VALUES SHALL BE USED PER DOCUMENT, 101-35000.

***WARNING**
ON INSTALLATION, SET WIRE DISC TO CRIMP HEIGHT REFERENCE SETTING FOR LARGEST WIRE SIZE. CRIMP HEIGHT REFERENCE SETTINGS GREATER THAN THE VALUE SHOWN MAY CAUSE DAMAGE TO THE CRIMP TOOLING. REFER TO THE INSTRUCTION SHEET FOR PROPER SETUP AND ADJUSTMENTS.

ATLANTIC VERSION
Shown on sheets 1 of 4 & 2 of 4
(Pacific version shown on sheets 3 of 4 & 4 of 4)

LOC	DIST	REVISIONS					
A	66	P	LTN	DESCRIPTION	DATE	OWN	APVD
		B		ECR-15-004305	18MAR2015	YY	JT
		B1		ECR-17-00027	04JAN2017	YY	JDG
		C		ECR-18-001800	06FEB2018	YY	TE
		D		ECR-19-011792	25JUL2019	TB	TE

-	1	-	1	-	2119641-1	FEED CAM, AIR FEED	248					
-	1	1	1	1	2119082-9	CAM, SNAIL, INSULATION ADJUSTMENT	244					
-	1	1	1	1	2079764-1	WASHER, WAVE SPRING, CREST-TO-CREST	243					
-	1	1	1	1	2119083-1	RETAINER, INSULATION DIAL	242					
-	-	1	-	1	2119580-1	MECHANICAL FEED ASSEMBLY	239					
-	1	-	1	-	2844940-4	AIR FEED MODULE	238					
-	1	1	1	1	1-18028-0	WASHER, FLAT, REG M8	192					
-	1	1	1	1	6-993111-6	PIN, SLOTTED SPRING 3.0 X 14.0	177					
-	1	1	1	1	8-22280-7	SPRING, COMPRESSION	176					
-	1	1	1	1	1752353-2	GUIDE PIN,HOLDDOWN	175					
-	1	1	1	1	1901680-2	GUIDE PIN,HOLDDOWN	174					
-	REF	REF	REF	REF	994970-2	COUNTER, MAGNETIC	164					
-	1	1	1	1	455888-6	SPACER, CRIMPER	82					
-	1	1	1	1	1803607-4	DOCUMENTATION PACKAGE	71					
-	2	2	2	2	2-18032-2	SCR, SET, FLT PNT, M3 X 10.0	70					
-	1	1	1	1	2119740-1	TAG, IDENTIFICATION	67					
-	2	2	2	2	2168078-1	SCREW, DRIVE, RH, RoHS, 2 x .188	66					
-	1	1	1	1	1901681-1	HOLDDOWN, TERMINAL	65					
-	1	1	1	1	2168083-2	SCR, SKT HD CAP, RoHS, M4 X 8.0	60					
-	1	1	1	1	5-18022-5	SCR, HEX HD CAP, M4 X 6.0	59					
-	-	1	-	1	2063961-1	FEED FINGER	58					
-	4	4	4	4	2168400-4	SHCS, LOW HEAD, RoHS, M4 X 8	57					
-	2	2	2	2	2168083-8	SCR, SKT HD CAP, RoHS, M4 X 16	56					
-	2	2	2	2	5018030-1	NUT, HEX, REG, RoHS, M3	54					
-	2	2	2	2	986965-8	NUT, LOCK, HEX, TORQUE (M4)	53					
-	1	1	1	1	1-5018030-0	NUT, HEX, REG, RoHS, M3.5	52					
-	1	-	1	-	2063961-9	FEED FINGER	51					
-	1	1	1	1	1752354-6	STANDOFF,HOLD-DOWN	50					
-	1	2	1	2	18023-9	SCR, SKT HD CAP M4 X 6.0	49					
-	-	1	-	1	2119652-1	FEED CAM, PRE FEED	48					
-	-	1	-	1	2119653-1	FEED CAM, POST FEED	47					
-	1	1	1	1	2119655-5	APPLICATOR BASIC ASSEMBLY, EF	46					
-	1	1	1	1	1803517-1	RAM ASSEMBLY, EF ATLANTIC	44					
-	1	1	1	1	1803602-1	SCR, BHSC, RoHS (M8 X 25)	41					
-	8	8	8	8	1-18028-2	WASHER, FLAT, REG M4	33					
-	2	2	2	2	2168083-9	SCR, SKT HD CAP, RoHS, M4 X 20	31					
-	2	2	2	2	2168083-2	SCR, SKT HD CAP, RoHS, M4 X 8.0	29					
-	1	1	1	1	240639-1	STRIPPER (MACHINING)	27					
-	2	2	2	2	1-2168083-5	SCR, SKT HD CAP, RoHS, M4 X 30	25					
-	1	1	1	1	1752371-5	PLATE, STRIP GUIDE	24					
-	2	2	2	2	2-22281-3	SPRING, COMPRESSION	22					
-	1	1	1	1	1803292-4	DRAG	20					
-	2	2	2	2	1901259-3	GUIDE, LOWER STRIP	18					
-	4	4	4	4	1-2079383-1	SCR, BHSC, RoHS (M6 X 12)	17					
-	1	1	1	1	5-240641-2	SPACER	16					
-	1	1	1	1	1752360-1	SPACER,HOLD-DOWN	13					
-	1	1	1	1	240644-1	PLATE, REAR SHEAR	11					
-	-	-	-	-	-	-	10					
-	1	1	1	1	690482-4	PLATE, FRONT SHEAR	9					
-	1	2	2	1	1803000-8	ANVIL, COMBINATION, END FEED	8					
-	1	1	1	1	1-2217206-0	BLADE, SLUG	7					
-	1	1	1	1	2-240641-5	SPACER	5					
-	1	1	1	1	238011-4	BLOCK, CRIMPER SPACER	4					
-	1	2	2	1	1633965-2	CRIMPER, INSULATION O PREMIUM	3					
-	1	1	1	1	455888-8	SPACER, CRIMPER	2					
-	1	2	2	1	1-456404-8	CRIMPER, WIRE PREMIUM	1					
-	77	-	72	-	71	-	2	-	1	PART NO	DESCRIPTION	ITEM NO

DIMENSIONS: mm 		TOLERANCES UNLESS OTHERWISE SPECIFIED: 0 PLC ± 1 PLC ± 2 PLC ± 3 PLC ± 4 PLC ± ANGLES ± FINISH		DWN Y. YIN 21FEB2012 CHK G. BAILEY 21FEB2012 APVD S. XI 21FEB2012		TE Connectivity Harrisburg, PA 17105-3608	
MATERIAL:		FINISH:		NAME Ocean End Feed Applicator		SIZE A1 00779 C=2150067	
WEIGHT:		SCALE: 1:1		SHEET 1 OF 4		REV D	

LOC	DIST	REV	DESCRIPTION	DATE	OWN	APVD
A	66		SEE SHEET 1			

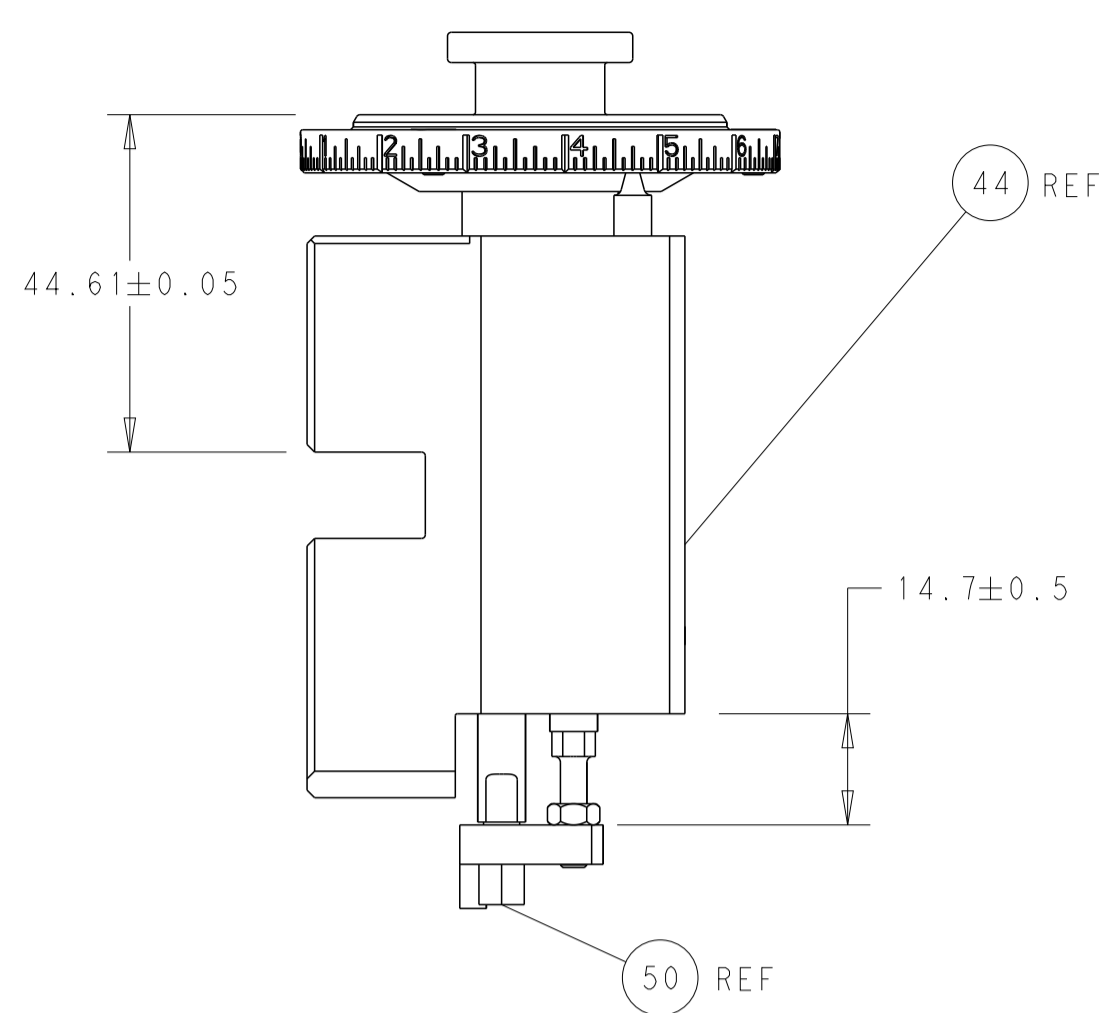

RAM AND HOLDDOWN SET-UP

FEED TYPE
MECHANICAL

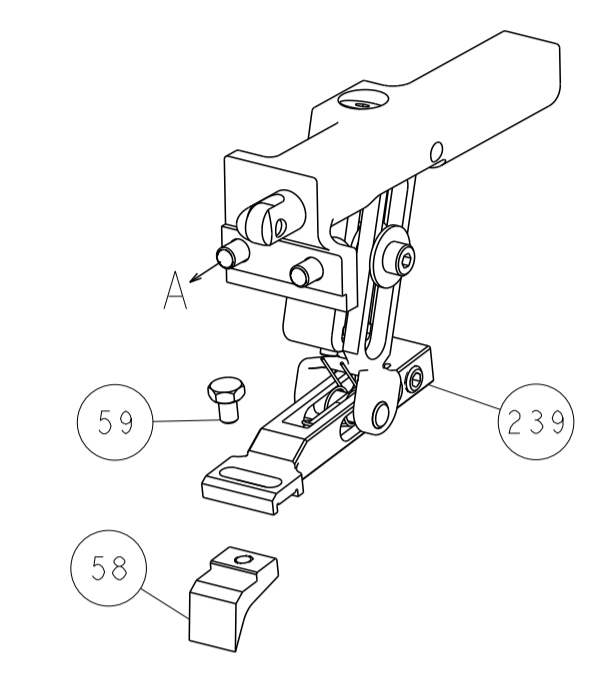

PNEUMATIC

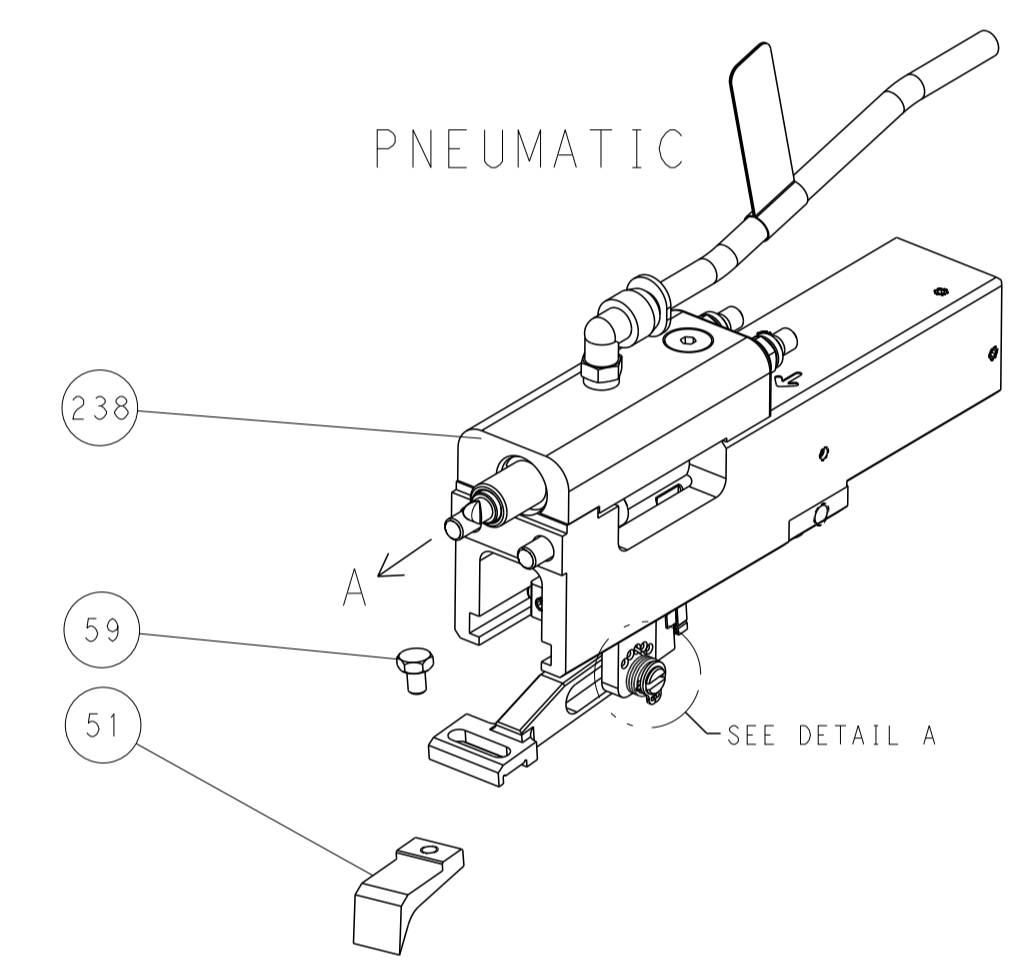

FEED SPRING
SETTING POSITION

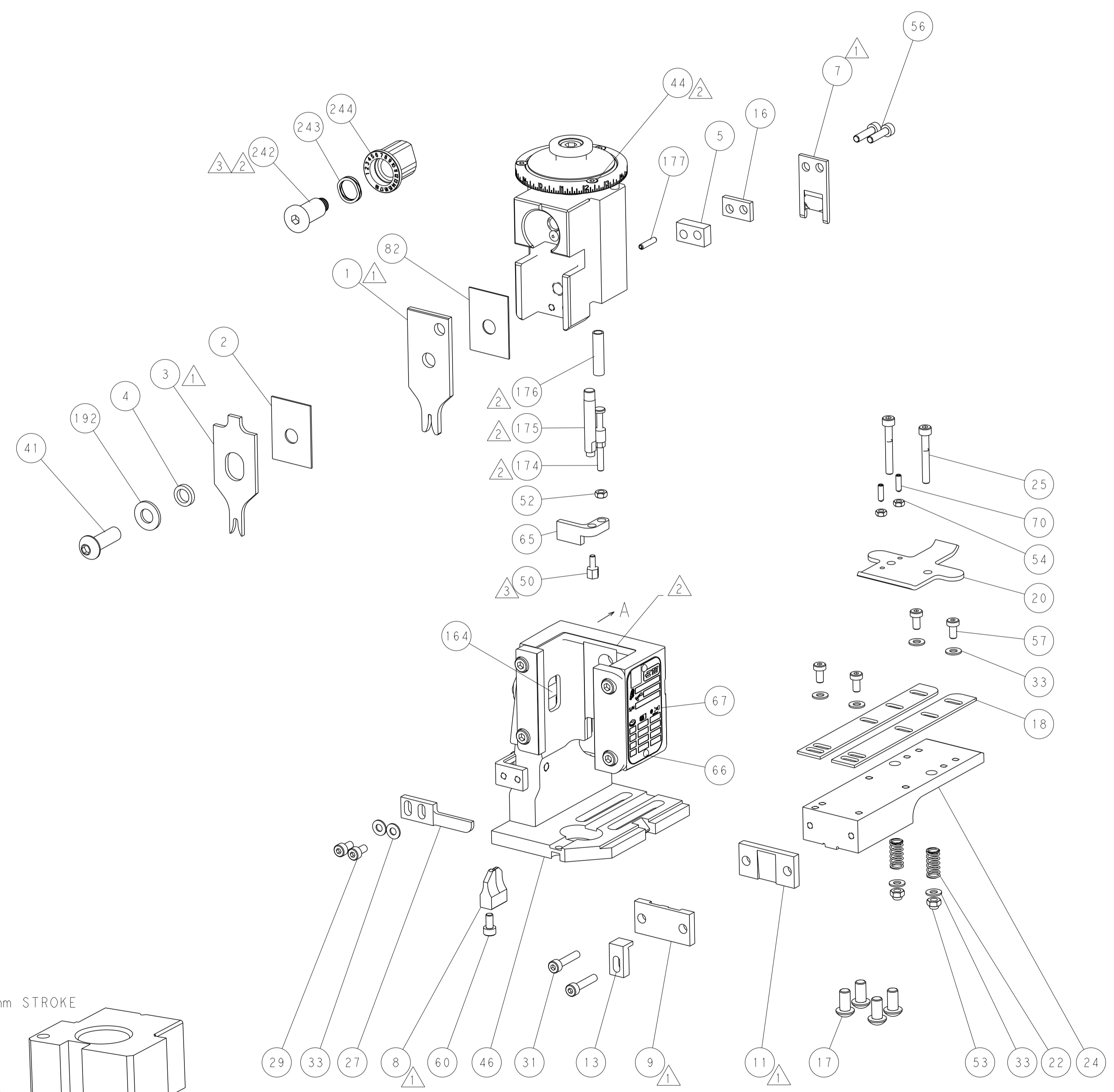
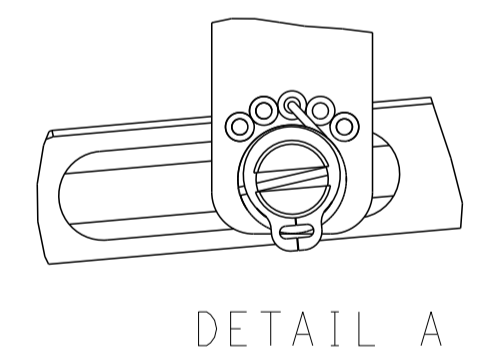

CAM POSITIONS

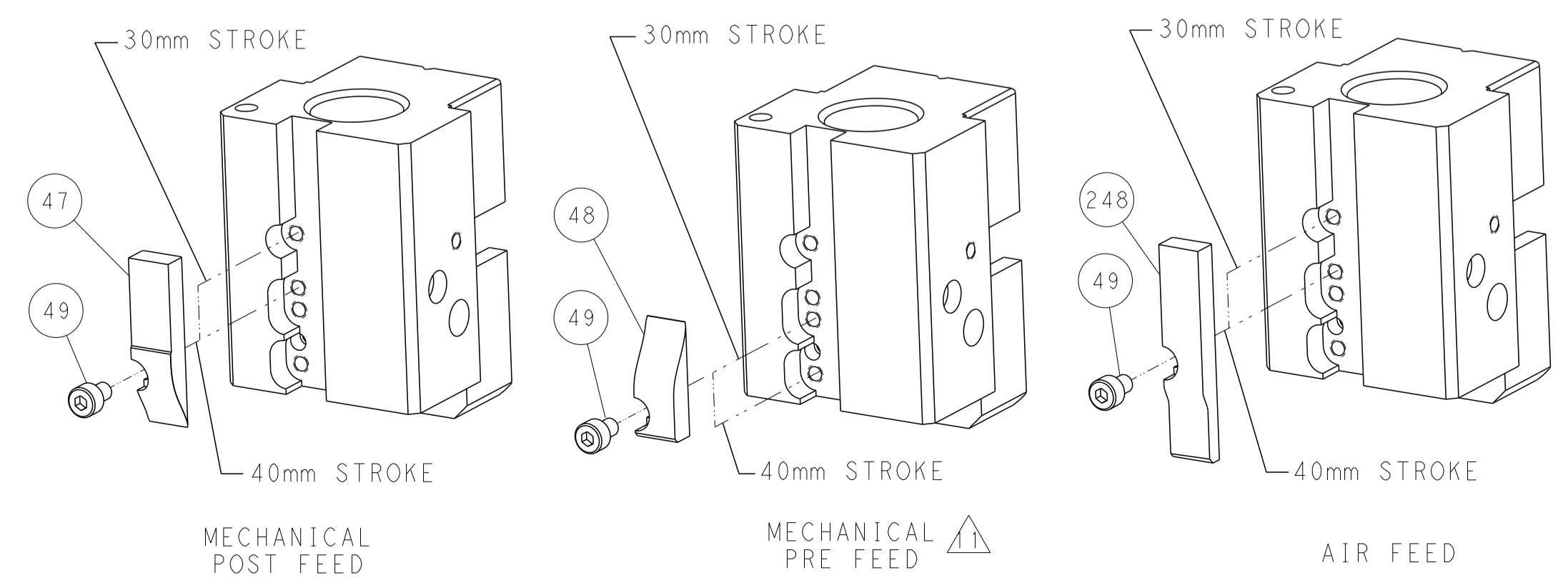

ATLANTIC VERSION
 Shown on sheets 1 of 4 & 2 of 4
 (Pacific version shown on sheets 3 of 4 & 4 of 4)

DIMENSIONS: mm 		TOLERANCES UNLESS OTHERWISE SPECIFIED: 0 PLC ± 1 PLC ± 2 PLC ± 3 PLC ± 4 PLC ± ANGLES ± FINISH		DWN Y. YIN 21FEB2012 CHK G. BAILEY 21FEB2012 APVD S. XI 21FEB2012 PRODUCT SPEC APPLICATION SPEC WEIGHT Customer Accessible Production Drawing		NAME Ocean End Feed Applicator SIZE CAGE CODE DRAWING NO. A1 00779 C=2150067 SCALE 1:1 SHEET 2 OF 4 REV D		RESTRICTED TO	
THIS IS DRAWING IS UNPUBLISHED. RELEASED FOR PUBLICATION BY TYCO ELECTRONICS CORPORATION. ALL RIGHTS RESERVED.				TE Connectivity Harrisburg, PA 17105-3608		SHEETS 3 & 4 ARE NOT REQUIRED FOR ATLANTIC VERSION			

PART NUMBER	REVISION	DESCRIPTION	FEED TYPE
2-2150067-1	D	FINE CRIMP HEIGHT ADJUST	MECHANICAL
2-2150067-2	D	FINE CRIMP HEIGHT ADJUST	PNEUMATIC
7-2150067-7	A	CRIMP TOOLING KIT	-

PACIFIC VERSION TERMINATOR
 INTERFACE ADAPTER

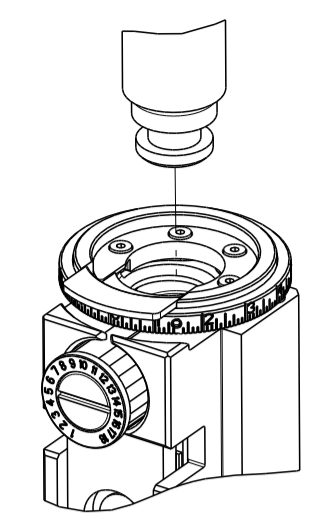

APPLICATOR DATA

CRIMP	SIZE	TYPE
WIRE	1.78 mm (.070)	F
INSUL	3.05 mm (.120)	O

APPLICATOR INSTRUCTIONS
 408-35043

TERMINAL DATA: TE TERMINAL TE CRIMP SPECIFICATION

TERMINAL NAME: .250 SERIES AUTOMOTIVE POSITIVE LOCK RECEP

WIRE STRIP LENGTH	INSULATION DIAMETER RANGE
4.20-5.20 mm (.165-.205 IN)	1.50-2.40 mm (.059-.094 IN)

TERMINAL APPLICATION SPECIFICATION 114-5060

TERMINALS APPLIED

TE TERMINAL	TE TERMINAL	TE TERMINAL	TE TERMINAL
170452-1	170452-2	368037-2	

WIRE SIZE	CRIMP HEIGHT mm [INCH]	CRIMP HEIGHT REFERENCE SETTING
0.50mm ²	1.36 +/- 0.05 [.054 +/- .002]	5.4
0.30mm ²	1.27 +/- 0.05 [.050 +/- .002]	6.4

- RECOMMENDED SPARE PARTS
- REFER TO SUPPLIED INSTRUCTION SHEET FOR CLEANING, LUBRICATION AND STORAGE OF APPLICATOR.
- APPLY PART NUMBER 2-23419-6 LOCTITE TO THREADS OF ITEM 242. APPLY PART NUMBER 1-23419-5 LOCTITE TO THREADS OF ITEM 50.
- CRIMP HEIGHT REFERENCE SETTING WAS THE SETTING USED WHEN THE APPLICATOR WAS QUALIFIED AT THE FACTORY. ADJUSTMENT MAY BE NECESSARY WHEN RUNNING APPLICATOR IN THE FIELD.
- UNLESS SPECIFIED OTHERWISE TORQUE VALUES SHALL BE USED PER DOCUMENT, 101-35000.

***WARNING**
 ON INSTALLATION, SET WIRE DISC TO CRIMP HEIGHT REFERENCE SETTING FOR LARGEST WIRE SIZE. CRIMP HEIGHT REFERENCE SETTINGS GREATER THAN THE VALUE SHOWN MAY CAUSE DAMAGE TO THE CRIMP TOOLING. REFER TO THE INSTRUCTION SHEET FOR PROPER SETUP AND ADJUSTMENTS.

LOC	DIST	REVISIONS					
		P	LTN	DESCRIPTION	DATE	OWN	APVD
A	66	-	-	SEE SHEET 1	-	-	-

-	1	1	2119082-9	CAM, SNAIL, INSULATION ADJUSTMENT	244	
-	1	1	2079764-1	WASHER, WAVE SPRING, CREST-TO-CREST	243	
-	1	1	2119083-1	RETAINER, INSULATION DIAL	242	
-	-	1	2119580-1	MECHANICAL FEED ASSEMBLY	239	
-	1	-	2844940-4	AIR FEED MODULE	238	
-	1	1	1-18028-0	WASHER, FLAT, REG M8	192	
-	4	4	2079383-9	SCR, BHSC, RoHS (M6 X 20)	186	
-	1	1	6-993111-6	PIN, SLOTTED SPRING 3.0 X 14.0	177	
-	1	1	8-22280-7	SPRING, COMPRESSION	176	
-	1	1	1752353-2	GUIDE PIN,HOLDDOWN	175	
-	1	1	1901680-2	GUIDE PIN,HOLDDOWN	174	
-	REF	REF	994970-2	COUNTER, MAGNETIC	164	
-	1	-	2119641-2	FEED CAM, AIR FEED	152	
-	1	1	2168083-8	SCR, SKT HD CAP, RoHS, M4 X 16	144	
-	-	1	2119653-2	FEED CAM, POST FEED	142	
-	1	1	2119655-6	APPLICATOR BASIC ASSEMBLY, EF	141	
-	1	1	1803518-1	RAM ASSEMBLY, EF PACIFIC	140	
-	1	1	455888-6	SPACER, CRIMPER	82	
-	1	1	1803607-4	DOCUMENTATION PACKAGE	71	
-	2	2	2-18032-2	SCR, SET, FLT PNT, M3 X 10.0	70	
-	1	1	2119943-1	WASHER, SPACER	69	
-	1	1	2119740-1	TAG,IDENTIFICATION	67	
-	2	2	2168078-1	SCREW, DRIVE, RH, RoHS, 2 x .188	66	
-	1	1	1901681-1	HOLDDOWN, TERMINAL	65	
-	1	1	5-18022-5	SCR, HEX HD CAP, M4 X 6.0	59	
-	-	1	2063961-1	FEED FINGER	58	
-	4	4	2168400-4	SHCS, LOW HEAD, RoHS, M4 X 8	57	
-	2	2	2168083-8	SCR, SKT HD CAP, RoHS, M4 X 16	56	
-	2	2	5018030-1	NUT, HEX, REG, RoHS, M3	54	
-	2	2	986965-8	NUT, LOCK, HEX, TORQUE (M4)	53	
-	1	1	1-5018030-0	NUT, HEX, REG, RoHS, M3.5	52	
-	1	-	2063961-9	FEED FINGER	51	
-	1	1	1752354-6	STANDOFF,HOLD-DOWN	50	
-	1	2	18023-9	SCR, SKT HD CAP M4 X 6.0	49	
-	-	1	2119652-1	FEED CAM, PRE FEED	48	
-	1	1	1803602-1	SCR, BHSC, RoHS (M8 X 25)	41	
-	8	8	1-18028-2	WASHER, FLAT, REG M4	33	
-	2	2	2168083-9	SCR, SKT HD CAP, RoHS, M4 X 20	31	
-	2	2	2168083-2	SCR, SKT HD CAP, RoHS, M4 X 8.0	29	
-	1	1	240639-1	STRIPPER (MACHINING)	27	
-	2	2	1-2168083-5	SCR, SKT HD CAP, RoHS, M4 X 30	25	
-	1	1	1752371-5	PLATE, STRIP GUIDE	24	
-	2	2	2-22281-3	SPRING, COMPRESSION	22	
-	1	1	1803292-4	DRAG	20	
-	2	2	1901259-3	GUIDE, LOWER STRIP	18	
-	1	1	5-240641-2	SPACER	16	
-	1	1	1752360-1	SPACER,HOLD-DOWN	13	
-	1	1	240644-1	PLATE, REAR SHEAR	11	
-	-	-	-	-	10	
-	1	1	690482-4	PLATE, FRONT SHEAR	9	
-	1	1	1803000-8	ANVIL, COMBINATION, END FEED	8	
-	1	1	1-2217206-0	BLADE, SLUG	7	
-	1	1	2-240641-5	SPACER	5	
-	1	1	238011-4	BLOCK, CRIMPER SPACER	4	
-	1	1	1633965-2	CRIMPER, INSULATION O PREMIUM	3	
-	1	1	455888-8	SPACER, CRIMPER	2	
-	1	1	1-456404-8	CRIMPER, WIRE PREMIUM	1	
-	77	22	21	PART NO	DESCRIPTION	ITEM NO

PACIFIC VERSION
 Shown on sheets 3 of 4 & 4 of 4
 (Atlantic version shown on sheets 1 of 4 & 2 of 4)

DIMENSIONS: mm 		TOLERANCES UNLESS OTHERWISE SPECIFIED: 0 PLC ± 1 PLC ± 2 PLC ± 3 PLC ± 4 PLC ± ANGLES ± FINISH		DWN Y. YIN 21FEB2012 CHK G. BAILEY 21FEB2012 APVD S. XI 21FEB2012 PRODUCT SPEC APPLICATION SPEC WEIGHT SCALE 1:1		NAME Ocean End Feed Applicator SIZE CAGE CODE DRAWING NO A1 00779 C=2150067 RESTRICTED TO Customer Accessible Production Drawing SHEET 3 OF 4 REV D	
-----------------------	--	---	--	--	--	--	--

LOC	DIST	REV	DESCRIPTION	DATE	OWN	APVD
A	66		SEE SHEET 1			

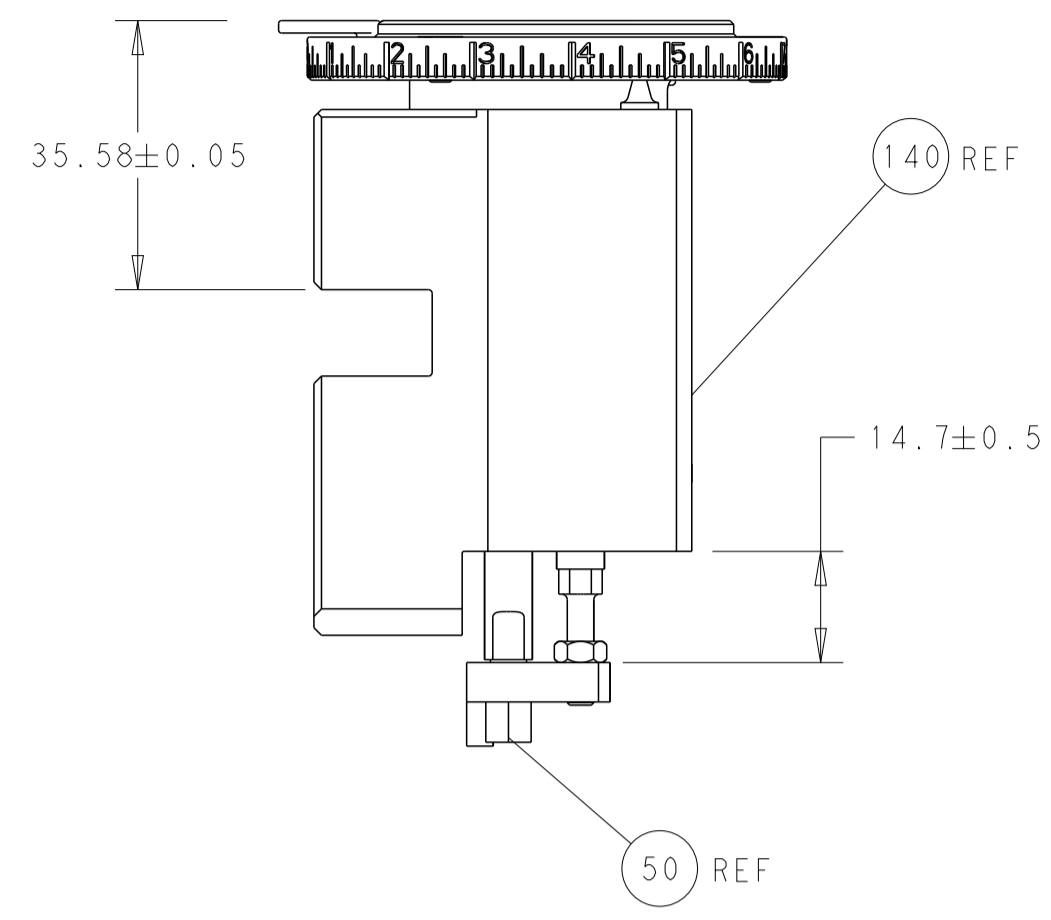

RAM AND HOLDDOWN SET-UP

FEED TYPE
MECHANICAL

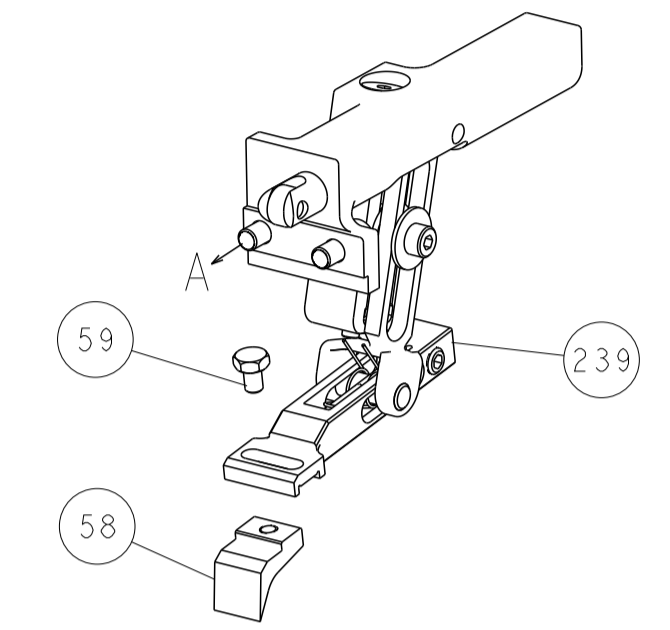

PNEUMATIC

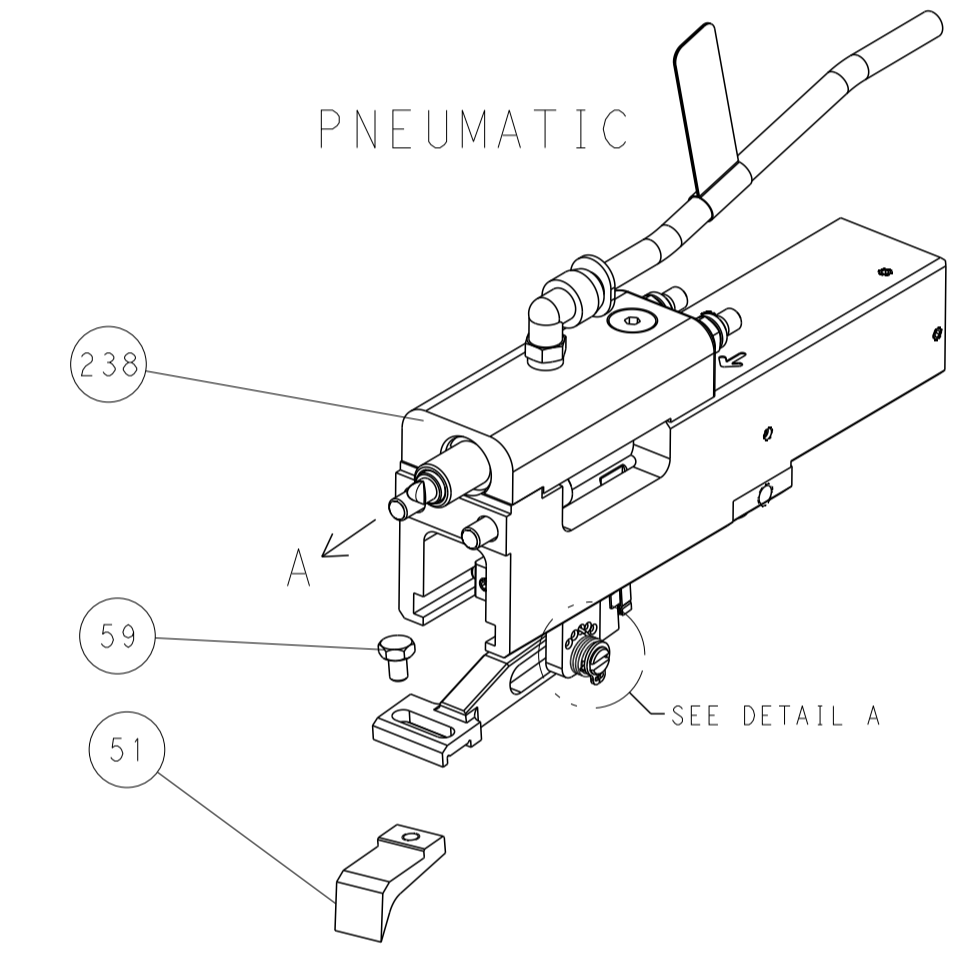

FEED SPRING
SETTING POSITION

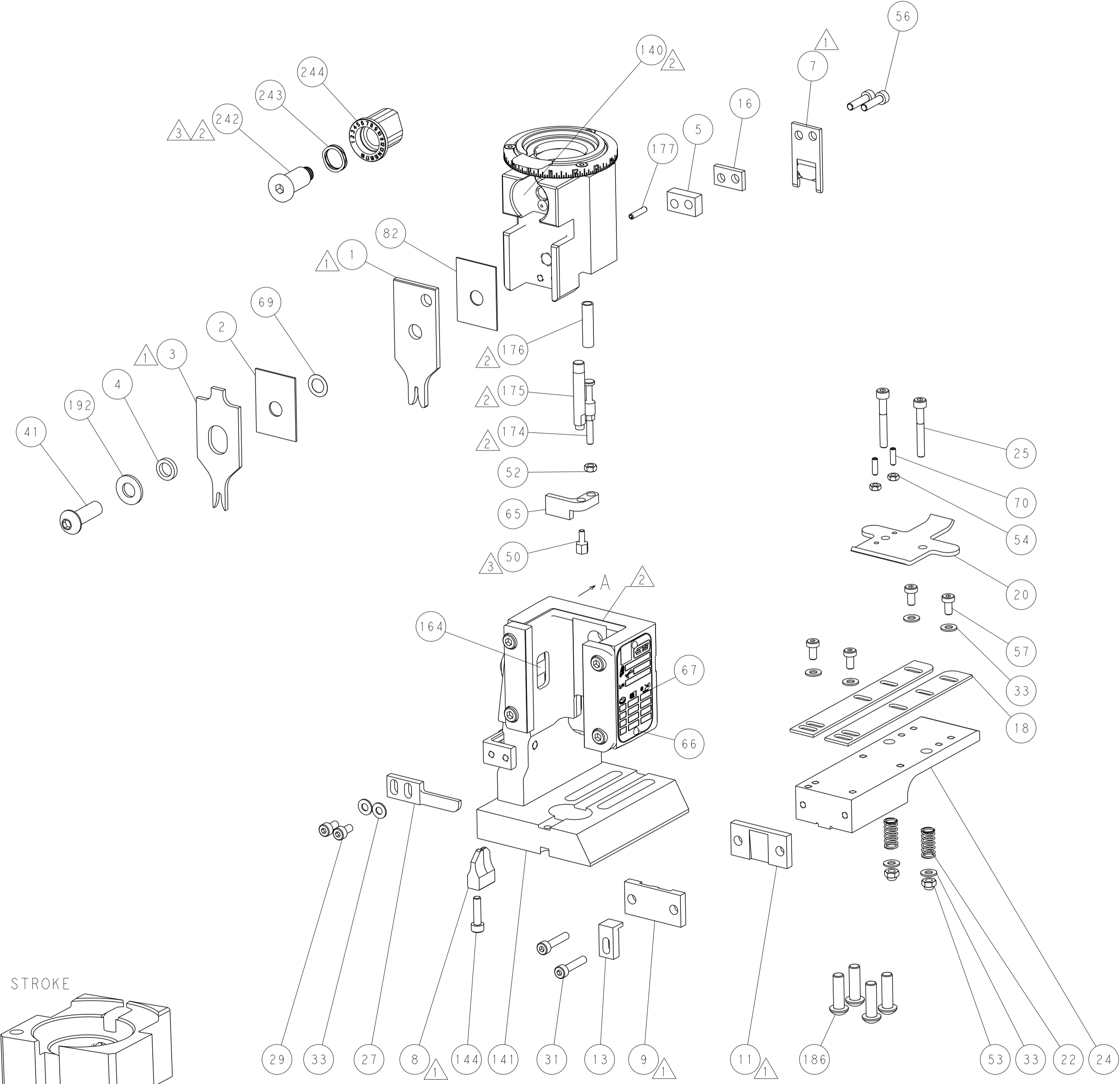
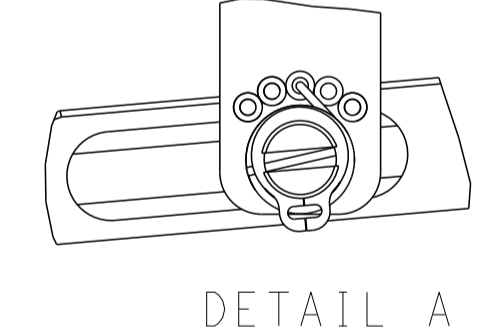

CAM POSITIONS

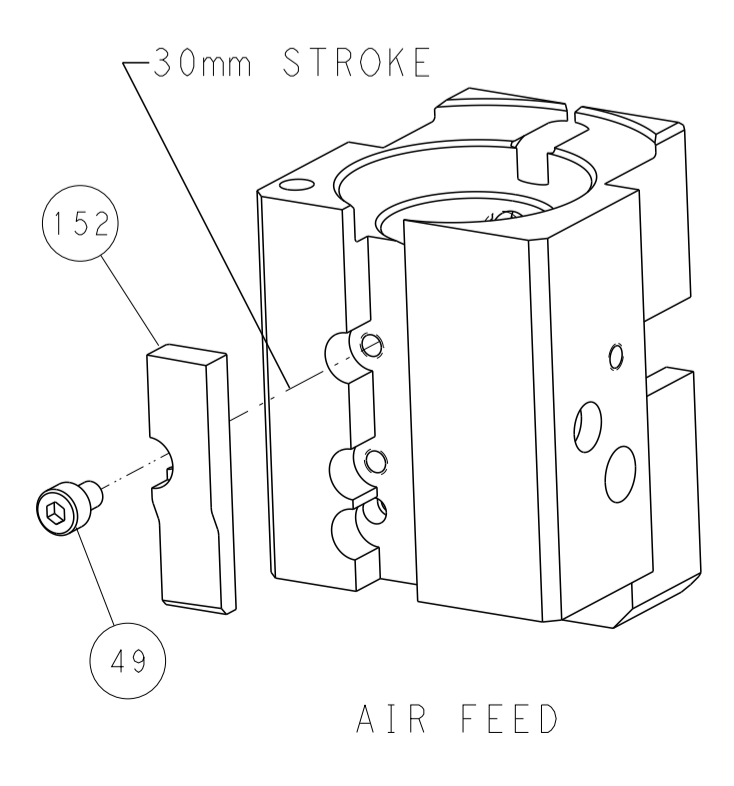
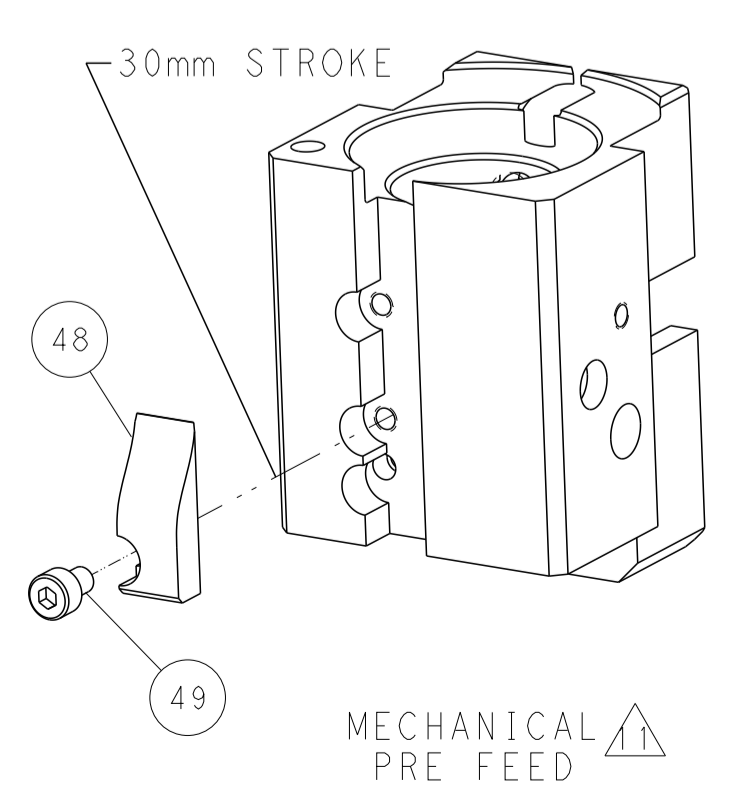
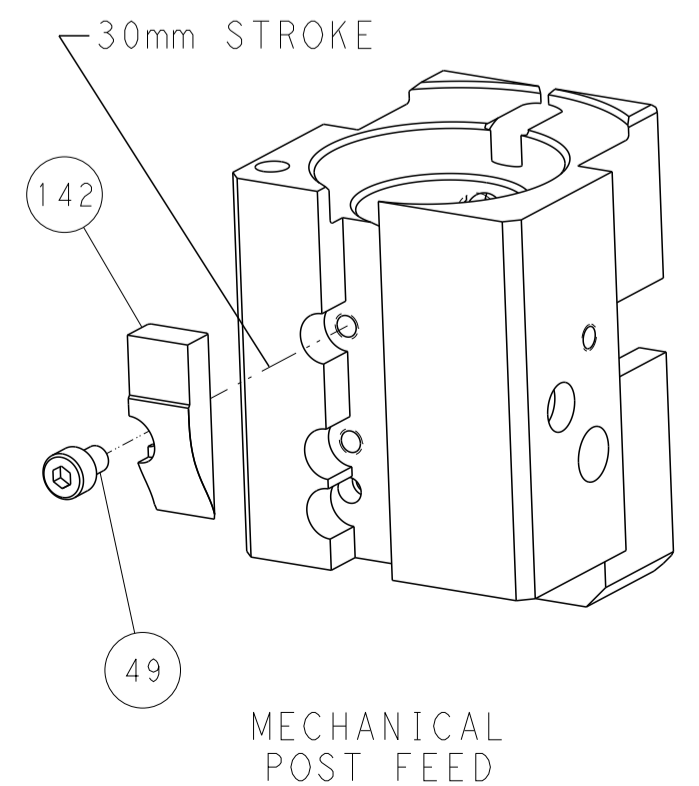

PACIFIC VERSION
 Shown on sheets 3 of 4 & 4 of 4
 (Atlantic version shown on sheets 1 of 4 & 2 of 4)

DIMENSIONS: mm 		TOLERANCES UNLESS OTHERWISE SPECIFIED: 0 PLC ± 1 PLC ± 2 PLC ± 3 PLC ± 4 PLC ± ANGLES ± FINISH		DWN Y. YIN 21FEB2012 CHK G. BAILEY 21FEB2012 APVD S. XI 21FEB2012 NAME PRODUCT SPEC APPLICATION SPEC WEIGHT Customer Accessible Production Drawing		STE TE Connectivity Harrisburg, PA 17105-3608 NAME Ocean End Feed Applicator SIZE CAGE CODE DRAWING NO A1 00779 C=2150067 SCALE 1:1 SHEET 4 OF 4 REV D	
-----------------------	--	---	--	---	--	---	--