

THIS DRAWING IS UNPUBLISHED. RELEASED FOR PUBLICATION
 © COPYRIGHT - By - ALL RIGHTS RESERVED.

LOC	DIST	REVISIONS			DATE	DWN	APVD
AJ	16	P	LTR	DESCRIPTION			
		D2		ECR-12-005726	27MAR12	RK	MY

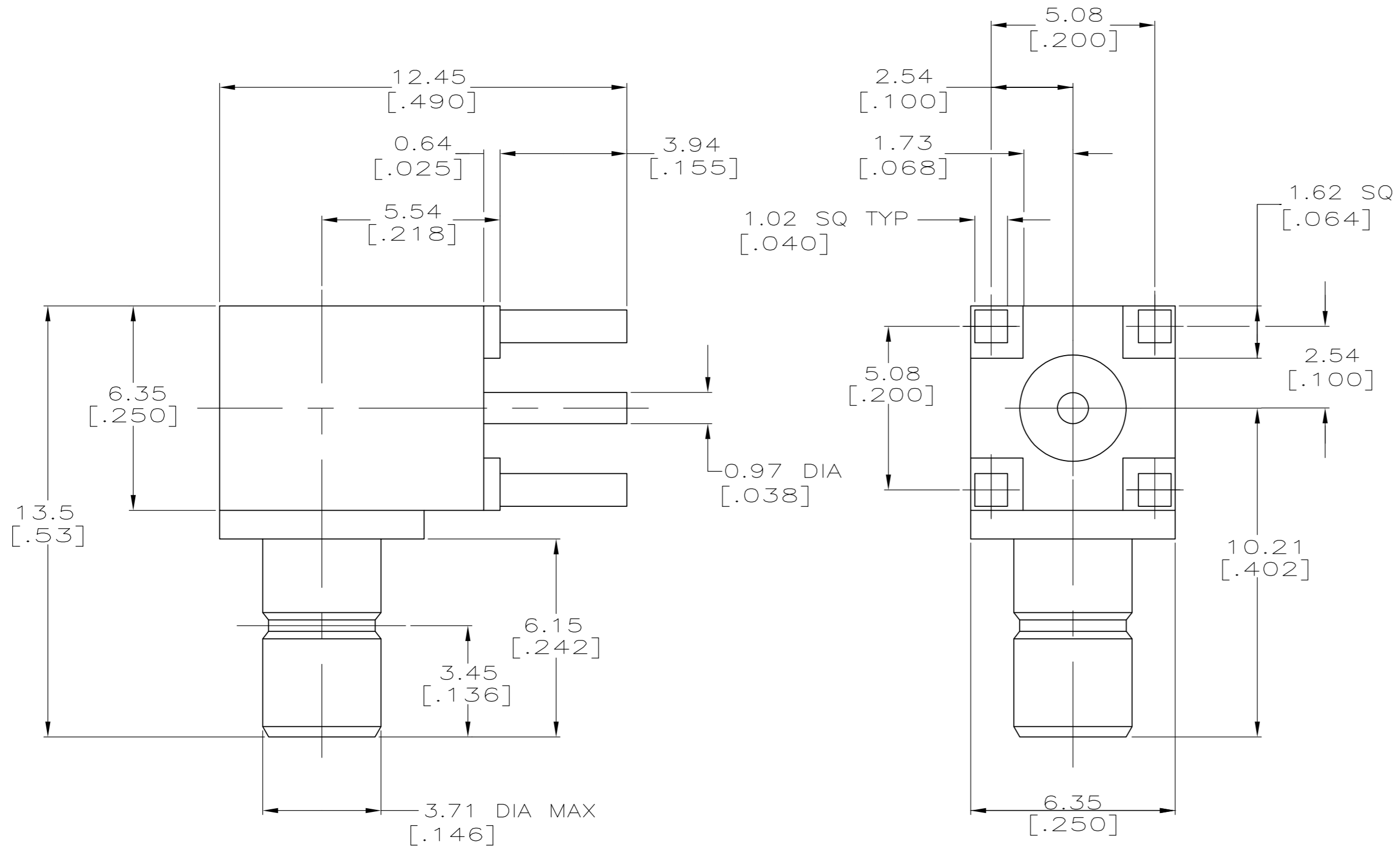

- 1 MATERIALS:
 BODY (LEG): ZINC ALLOY (ZAMAK 3)
 BODY (FRONT): BRASS PER QQ-B-626
 CENTER CONTACT: BRASS PER QQ-B-626
 INSULATORS: PTFE PER ASTM-D-1710
- 2 MATERIALS:
 BODY (LEG): BRASS PER MIL-C-21768
 BODY (FRONT): BRASS PER QQ-B-626
 CENTER CONTACT: BRASS PER QQ-B-626
 INSULATORS: PTFE PER ASTM-D-1710
- 3 FINISH:
 CENTER CONTACT: GOLD PL PER MIL-G-45204
 BODY (LEG): NICKEL PL PER 112-25-1
 BODY (FRONT): GOLD PL PER 112-162-5
- 4 FINISH:
 CENTER CONTACT: GOLD PL PER MIL-G-45204
 BODY (LEG): GOLD PL PER 112-162-5
 BODY (FRONT): GOLD PL PER 112-162-5
- 5 FINISH:
 CENTER CONTACT: GOLD PL PER MIL-G-45204
 BODY (LEG): NICKEL PL PER 112-25-1
 BODY (FRONT): NICKEL PL PER 112-25-1
- 6. INTERFACE PER MIL-C-39012
- 7 FINISH:
 CENTER CONTACT: GOLD PL PER MIL-G-45204
 BODY (LEG): TIN-LEAD PL PER ASTM-B-545
 BODY (FRONT): GOLD PL PER 112-162-5
- 8 FINISH:
 CENTER CONTACT: GOLD PL PER MIL-G-45204
 BODY (LEG): TIN-LEAD PL PER ASTM-B-545
 BODY (FRONT): NICKEL PL PER 112-25-1

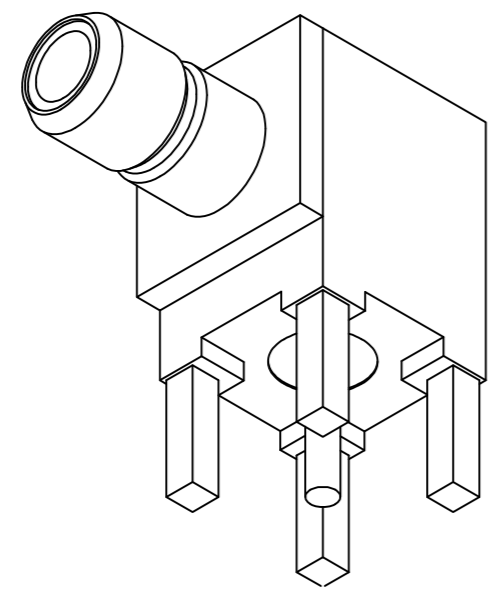

ISOMETRIC VIEW

SUPERSEDED BY 414337-1	2 8	414026-6
SUPERSEDED BY 414026-2	2 7	414026-5
OBSOLETE	2 3	414026-4
	2 5	414026-3
	2 4	414026-2
	1 3	414026-1
NOTES	PART NUMBER	

THIS DRAWING IS A CONTROLLED DOCUMENT.		DWN B. WERNER 11-26-90	TE Connectivity	
DIMENSIONS: mm [INCHES]		CHK J. McLEOD 2-4-91		
TOLERANCES UNLESS OTHERWISE SPECIFIED:		APVD J. McLEOD 2-4-91	NAME SMB,RIGHT ANGLE,JACK RECEPTACLE,PCB MOUNTING	
0 PLC ± -		PRODUCT SPEC	SIZE A2	
1 PLC ± -		APPLICATION SPEC	CAGE CODE 00779	
2 PLC ± .25 [.010]			DRAWING NO C=414026	
3 PLC ± .13 [.005]			RESTRICTED TO	
4 PLC ± -			SCALE 8:1	
ANGLES ± -			SHEET 1 of 1	
FINISH		WEIGHT -	REV D2	
1 2		CUSTOMER DRAWING		
3 4 5 7 8				