



Automotive HDMI

MX50/53 Series

CONNECTOR

MB-0242-2

August 2016

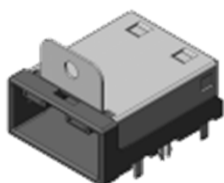

Receptacle Connector

(Type E)
MX50019NQ1



Plug Connector
(Type E)
MX50019FQ1



Inline Connector
(Straight Type)
(Type A)
MX53019MB1

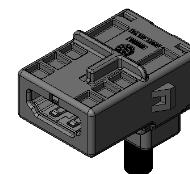

Inline Connector
(Angle Type)
(Type A)
MX53B19MB1

Recently for car interiors, the demand for infotainment devices such as blu-ray players and connectivity with digital portable devices like smartphones has been increasing. To meet this demand, JAE has developed the MX50/53 Series HDMI connector for automotive applications, and now a new Type A Inline Connector (Angle Type) has been added to enhance the line-up.

The MX50/53 Series is a connector compatible with the HDMI standard Type E which was standardized for automotive applications. The connector is designed to satisfy high-speed transmission performance while taking into account automotive use requirements, and it achieves both mechanical and environment suitability through features such as exclusively developed shielded wires.

**HDMI: High-Definition Multimedia Interface, trademark of HDMI Licensing, LLC.

Features

- 1.5mm horizontal pitch, 2-row, 19 position. (Type E)
- Impedance matching design, compatible with high-speed transmission.
- Mechanical lock to resist twisting in the mated connector. (Type E)
- HDMI Type A inline product is also available.
- Supplied as a harness product to ensure transmission performance reliability.

General Specifications

- Number of Contacts: 19 position
- Contact Resistance: Contact area, 30mΩmax.; Shell area, 50mΩmax.
(amount of change from initial)
- Rated Voltage: AC500V (un-mated)
- Operating Temperature: -40 Deg. C to +85 Deg. C
- Rated Current: 0.5A per terminal
- Insulation Resistance: 100MΩmin. (un-mated)
- Applicable Board Thickness: 1.6mm
- Applicable Wire: Shielded twist pair wire (only for harness)

Materials and Finishes

- Receptacle Connector

Component	Material / Finish
Pin Contact	Brass / Contact area: Au plating Terminal area: Sn plating
Housing	30%GF SPS, other
Shell	Copper alloy / Sn plating, other

- Plug Connector

Component	Material / Finish
Socket Contact	Copper alloy / Contact area: Au plating Terminal area: Sn plating
Housing	PBT, other
Shell	Copper alloy / Sn plating, other

- Type A Inline Connector (common for Straight and Angle Type)

Component	Material / Finish
Pin Contact	Brass / Au plating
Housing	PBT, other
Shell	Copper alloy / Sn plating, other

External Dimensions

■ Receptacle Connector (MX50019NQ1) Drawing No. SJ109697 (Type E) Unit: mm

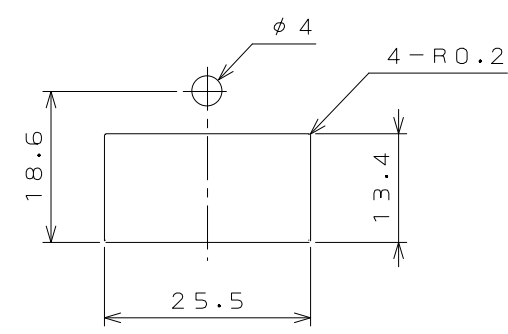
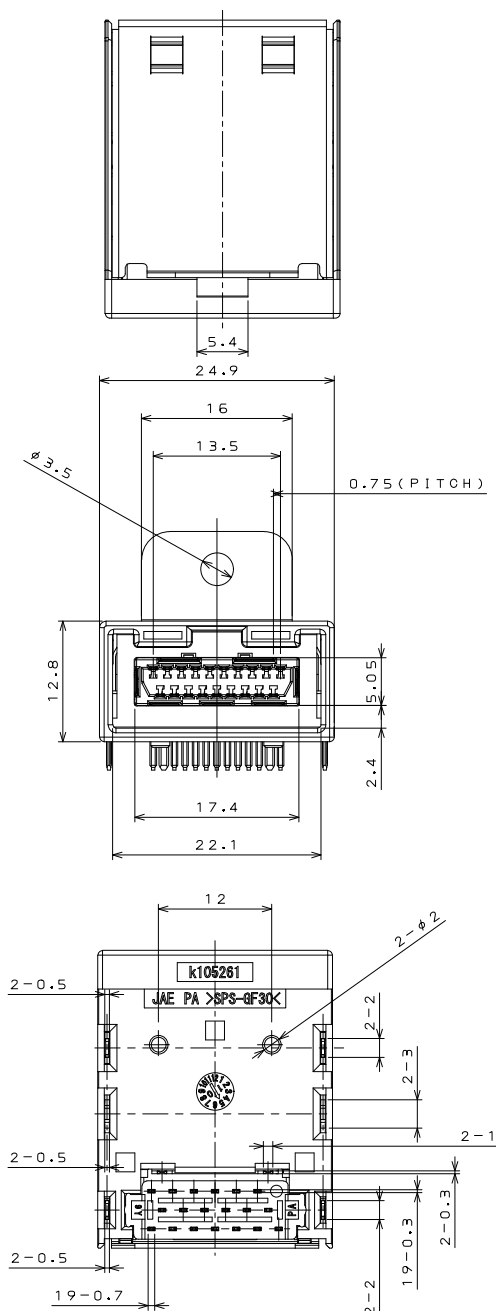

PANEL CUT OUT DIMENSION (REF.)
パネル開口寸法 (参考)

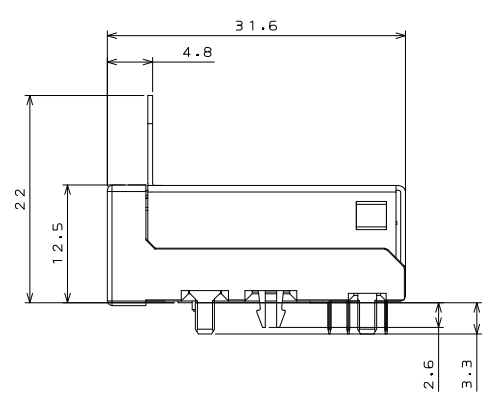

Note) Please contact us concerning the attachment method to the flange, whether the products are with or without flange, and the position of the flange.

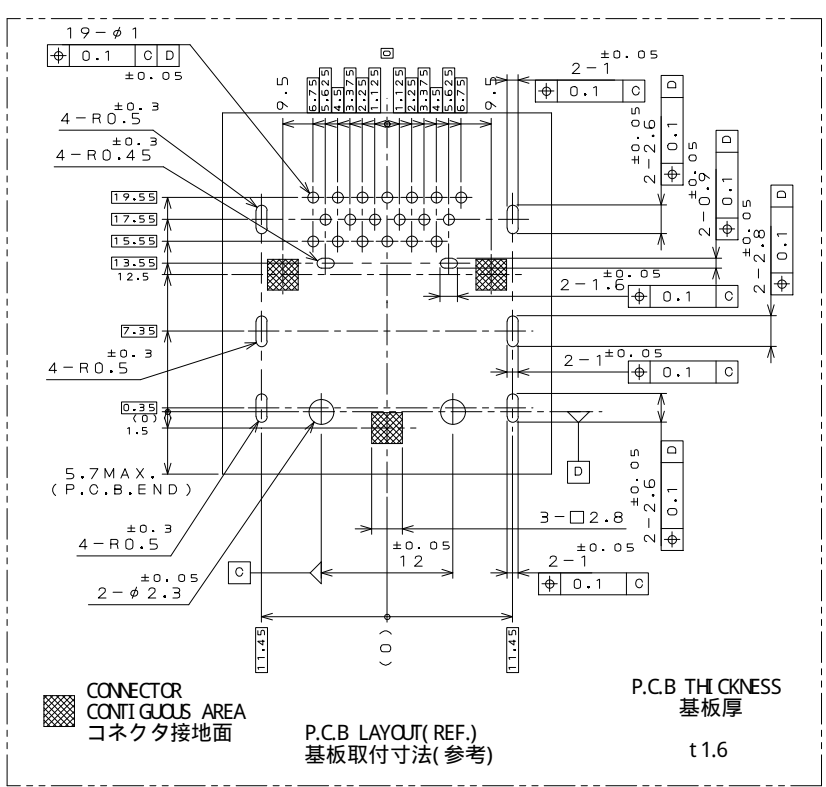

External Dimensions

- Plug Connector (MX50019FQ1) (for reference)
(Type E)

Unit: mm

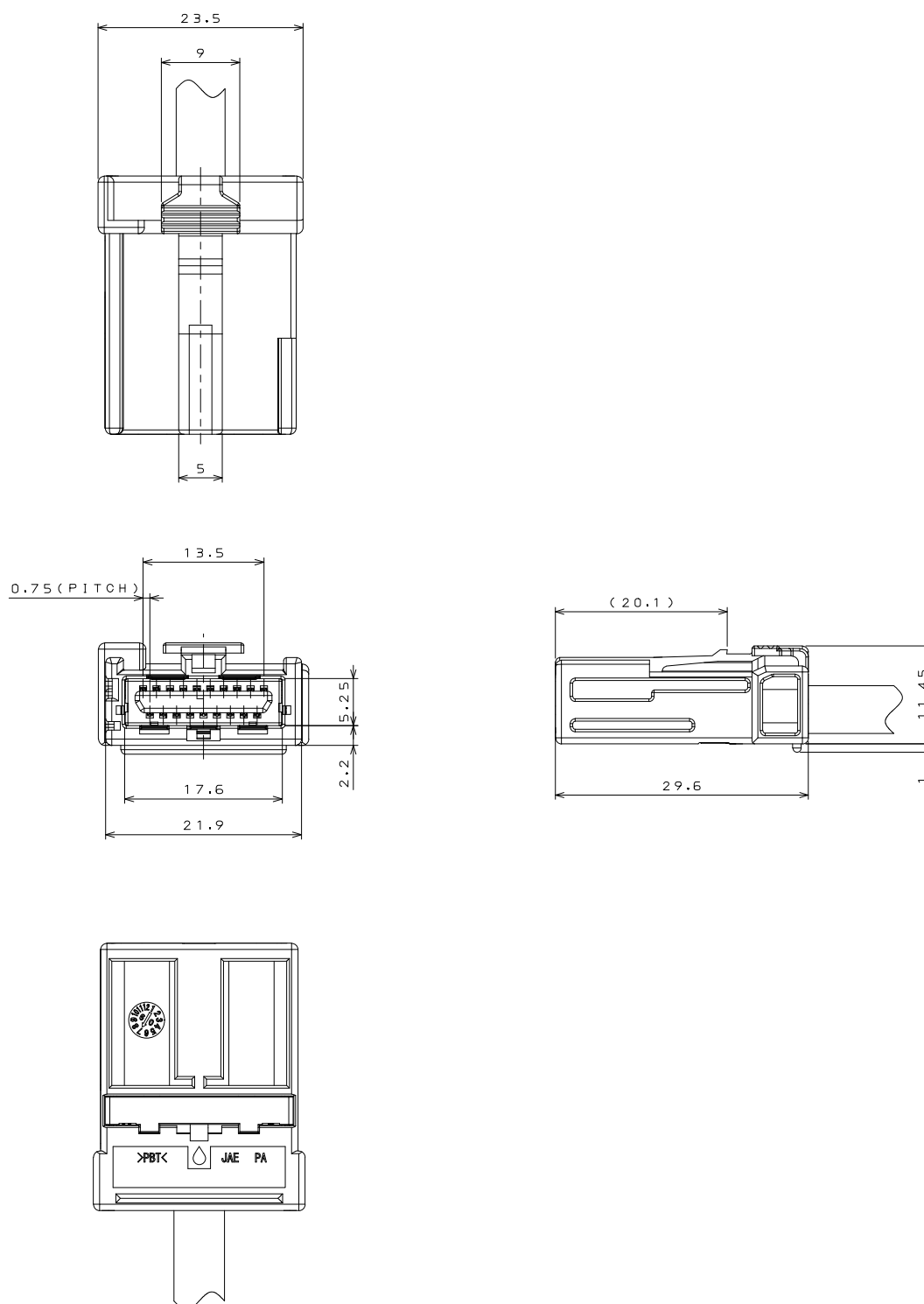

Note : Plug Connector is a harness product.
It is not sold as an individual connector.

External Dimensions

- Inline Connector: Straight Type (MX53019MB1) (for reference)
(Type A) Unit: mm

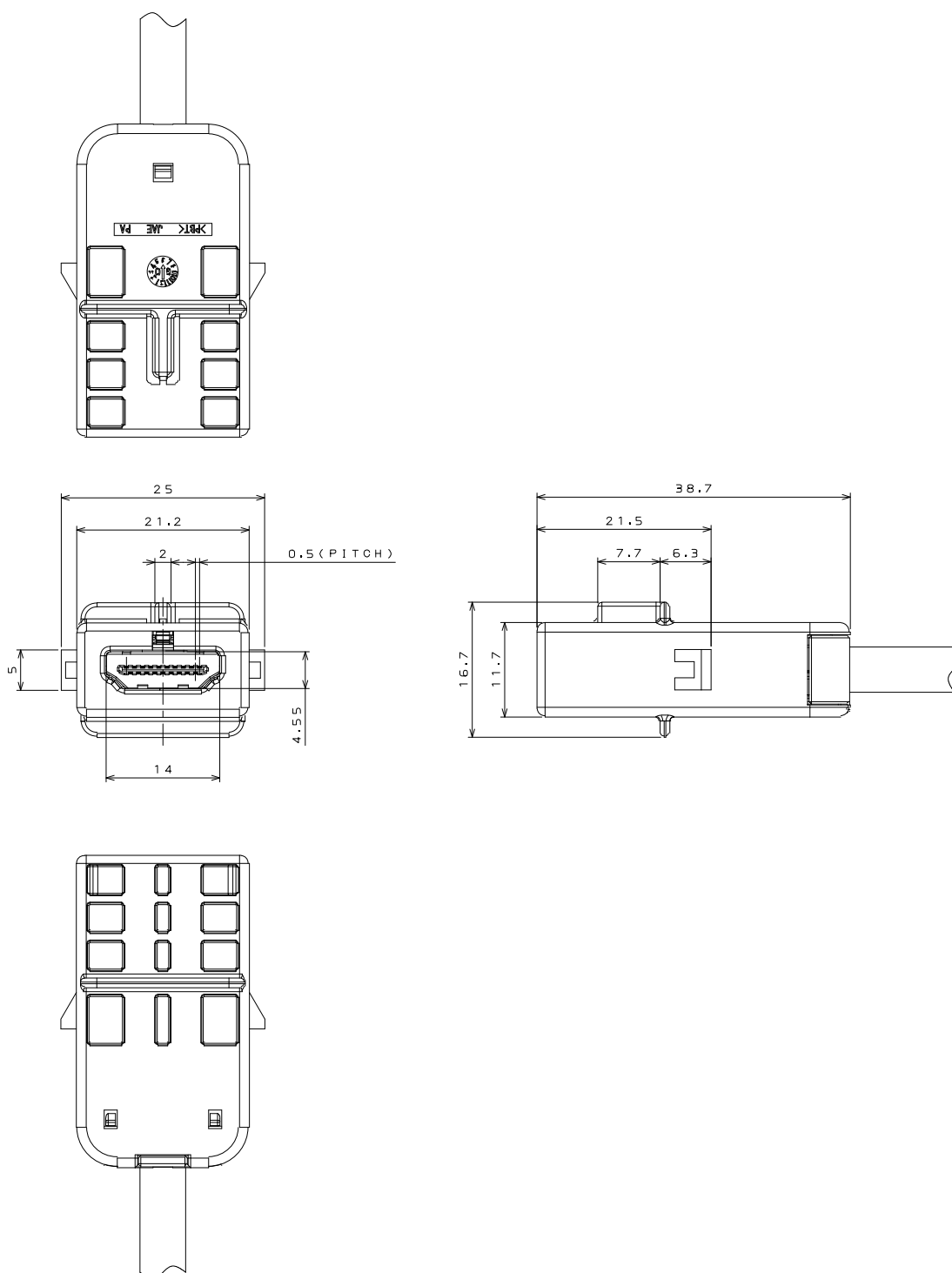

Note :

Type A Inline Connector (Straight Type) is a harness product.
It is not sold as an individual connector.

External Dimensions

- Inline Connector: Angle Type (MX53B19MB) (for reference)
(Type A) Unit: mm

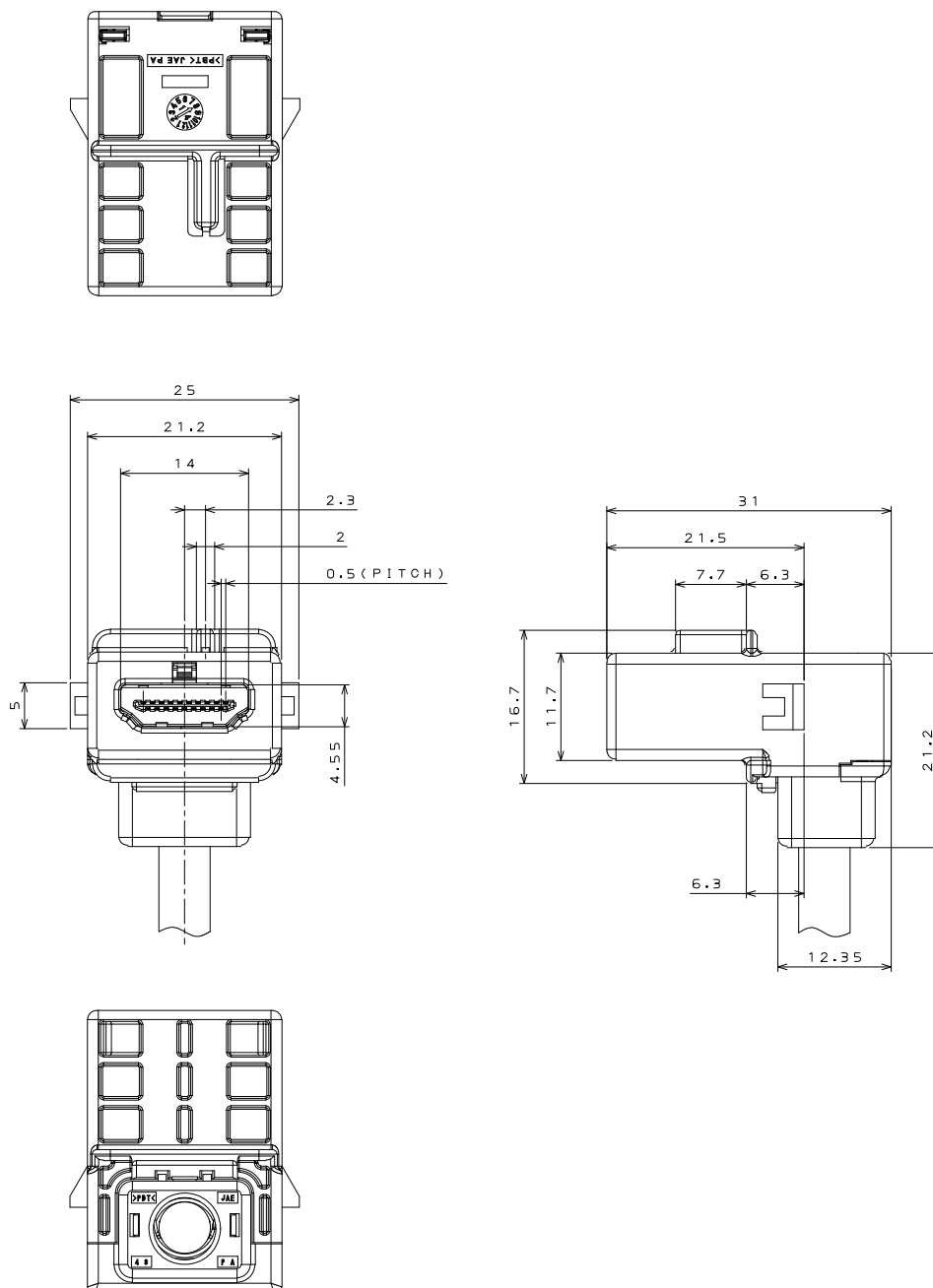

Note :

Type A Inline Connector (Angle Type) is a harness product.
It is not sold as an individual connector.

Other

Specifications

JACS-10628 (Type E Connector)
JACS-10660 (Type A Inline Connector)

Notice:

1. The values specified in this brochure are only for reference. The products and their specifications are subject to change without notice. Contact our sales staff for further information before considering or ordering any of our products. For purchase, a product specification must be agreed upon.

2. Users are requested to provide protection circuits and redundancy circuits to ensure safety of the equipment, and sufficiently review the suitability of JAE's products to the equipment.

3. The products presented in this brochure are designed for the uses recommended below.

We strongly suggest you contact our sales staff when considering use of any of the products in any other way than the recommended applications or for a specific use that requires an extremely high reliability.

(1) Applications that require consultation:

(i) Please contact us if you are considering use involving a quality assurance program that you specify or that is peculiar to the industry, such as:

Automotive electrical components, train control, telecommunications devices (mainline), traffic light control, electric power, combustion control, fire prevention or security systems, disaster prevention equipment, etc.

(ii) We may separately give you our support with a quality assurance program that you specify, when you think of a use such as :

Aviation or space equipment, submarine repeaters, nuclear power control systems, medical equipment for life support, etc.

(2) Recommended applications include:

Computers, office appliances, telecommunications devices (terminals, mobile units), measuring equipment, audiovisual equipment, home electric appliances, factory automation equipment, etc.

Japan Aviation Electronics Industry, Limited

* The specifications in this brochure are subject to change without notice. Please contact JAE for information.