

RAIN SENSOR

RC-SPC1KA is a thick film technology rain sensor. This device is realized in Allumina (AL₂O₃) substrate, this material is endowed with a big reliability from an electrical thermal point of view.

The sensor consists of three parts :

- 1) Capacitive sensor (Face A)
- 2) Heater generator
- 3) Temperature Sensor

The Face A is the sensitivity area (capacitive sensor) this area is exposed to natural agent (rain); In dry condition the value of the capacitor is nominal 100pF, In presence of the rain the capacitance goes to high valued respect the dry condition; The ratio changing is over 420%, in the table N.1 you can verify the capacitance change characteristics.

On Face B is present the heating circuit the temperature sensor (NTC component) and the connection interface (six pads).

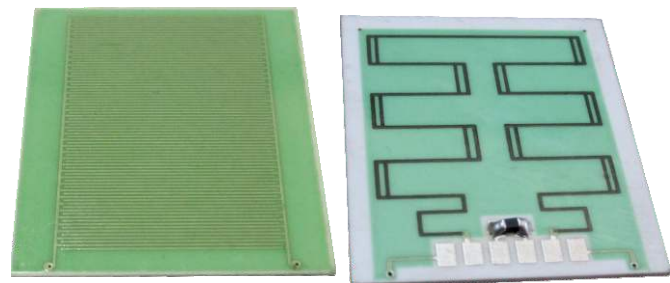

Face A
Capacitive Sensor

Face B
Heating circuit +
NTC component

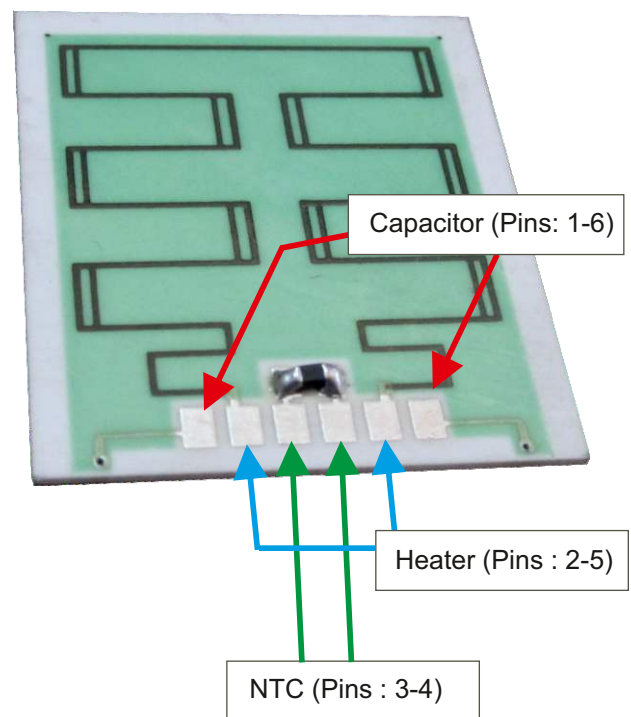

Electrical Parameters:

Capacity Value : 100pF 10%

R Value(heater) : 42 ohm 10%

NTC Value : 1K+- 10%

Mechanical Dimensions:

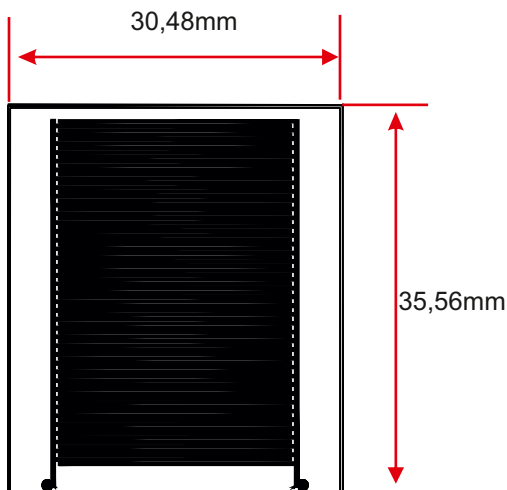

Applications :

- Home and building automation
- Metereological Reading
- Agriculture Automation

RAIN SENSOR

Capacitive change characteristic

Sensitive area		Capacitance
% Dry	% water	pF
100	0	100
75	25	320
60	40	450
50	50	2000
0	100	>3000

Table 1

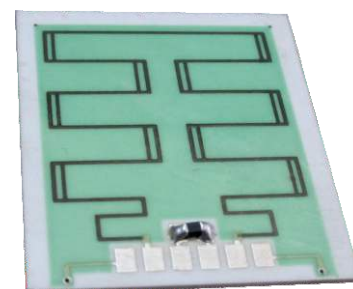

On the rear of the rain sensor there is a temperature sensor NTC with a nominal resistance value 1Kohm (25°C), it's possible use this sensor to monitor the environment temperature. It's possible to control the heater against particular environment condition as frost and dump.

With these 3 functions :

- Measure the capacitance (Table 1)
- Measure the environment temperature (Table 2)
- Heater control (Table 3)

It's possible establish if it's raining or not.

NTC characteristic

T (°C)	Rnom (Ohm)
-5	3572
0	2844
5	2280
10	1839
15	1492
20	1218
25	1000
30	825
35	685
40	571
45	479
50	403
55	341
60	290
65	247
70	212
75	182
80	157
85	136

Table 2

Heater Time to rise different temperature

t (sec)	°C Sensor Substrate
0	27
15	40
30	50
45	60
60	70
75	75
90	77
105	78
120	81
135	83
150	85

Table 3

Note : The values contained in this page are considered typical properties only and are not intended to be used as specification limits. The above characteristics are to be verified in customer application.

The sensor can't support temperature higher than 200 °C , otherwise the soldering will be damaged.

RAIN SENSOR - Mechanical Dimensions

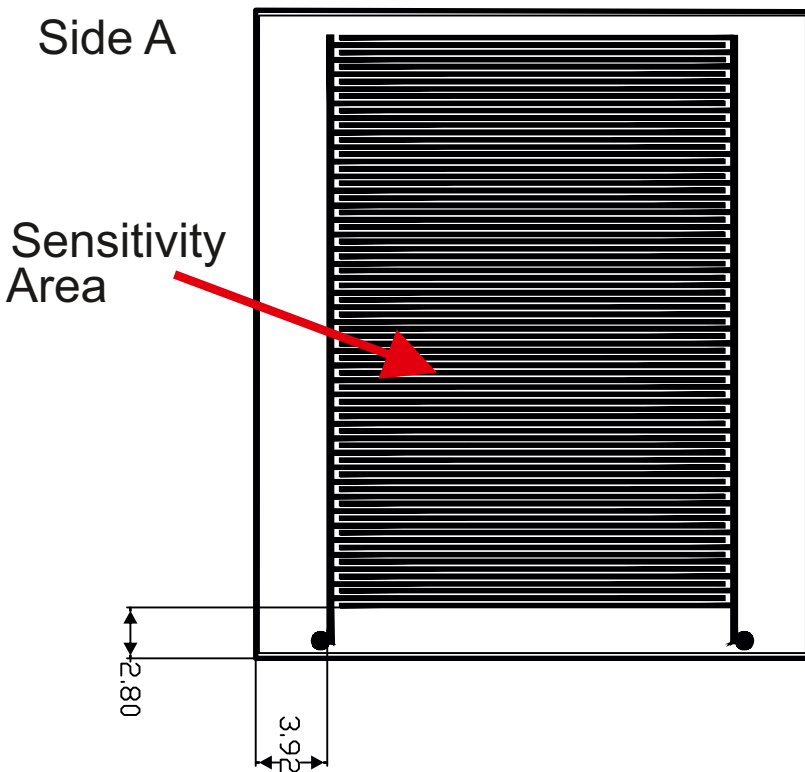

Note :Enclouser Consideration

For a good application, an enclosure that respects the following characteristics must be realized :

- Only the active surface of the sensor (sensitivity area - Face A) must be exposed to atmospheric agents.
- Face B must be protected as much as possible from the ingress of water by means of suitable sealants

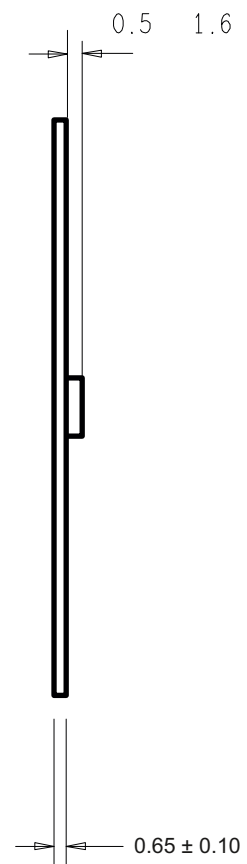
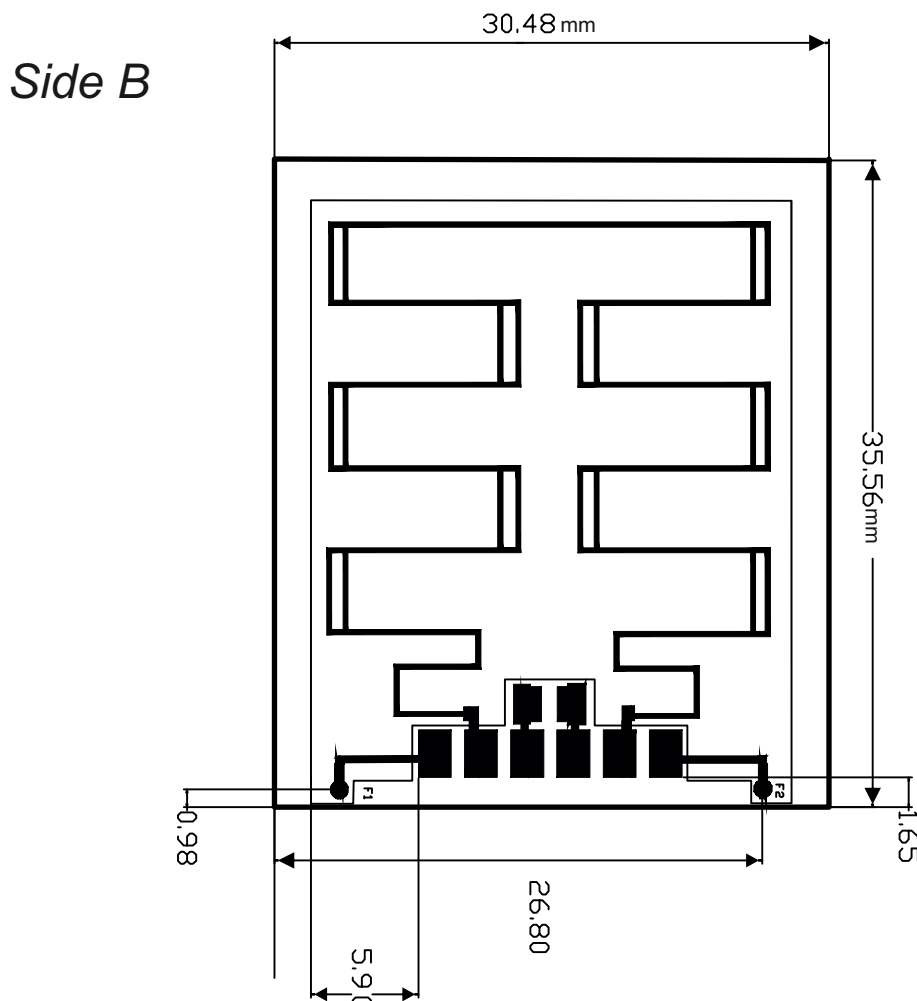

RAIN SENSOR - Application

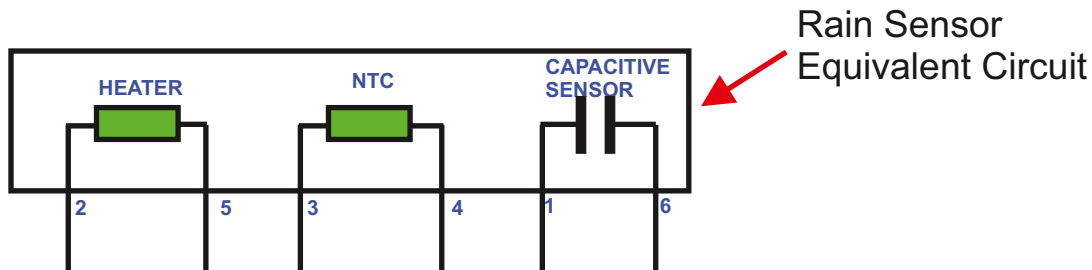

To read the changing of sensor capacitance, it's possible to do in two methods :

- Frequency measurements (counter mode) - Picture 1
- Pulse measurements (timer mode) - Picture 2

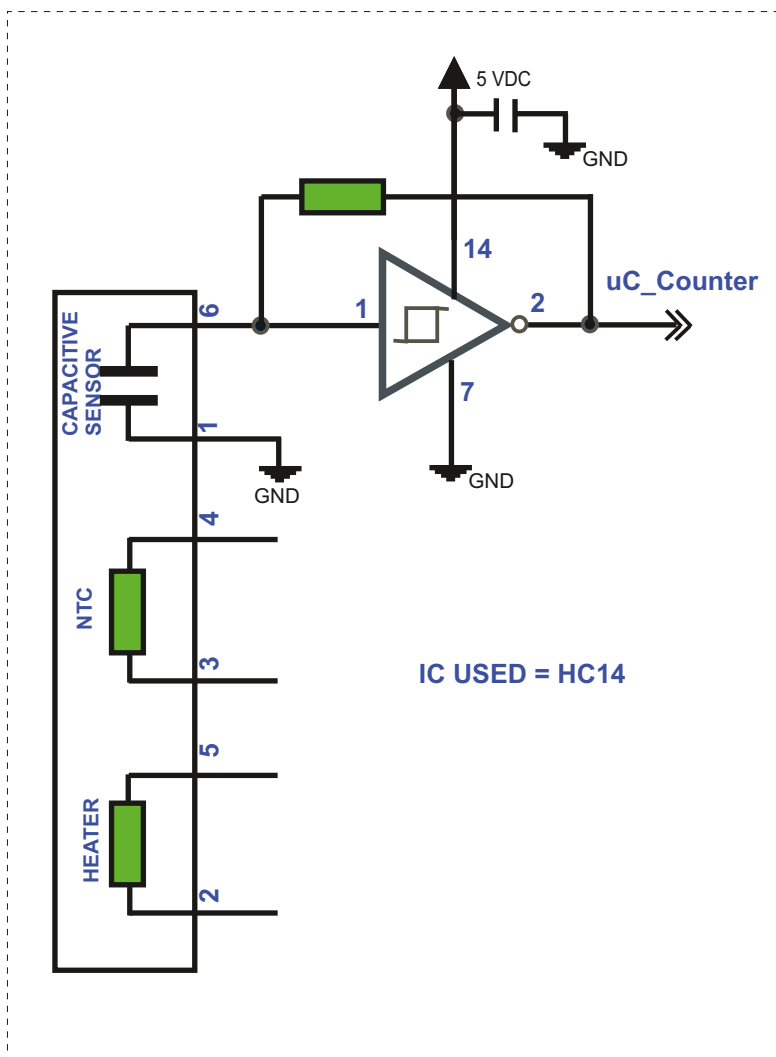

Picture 1

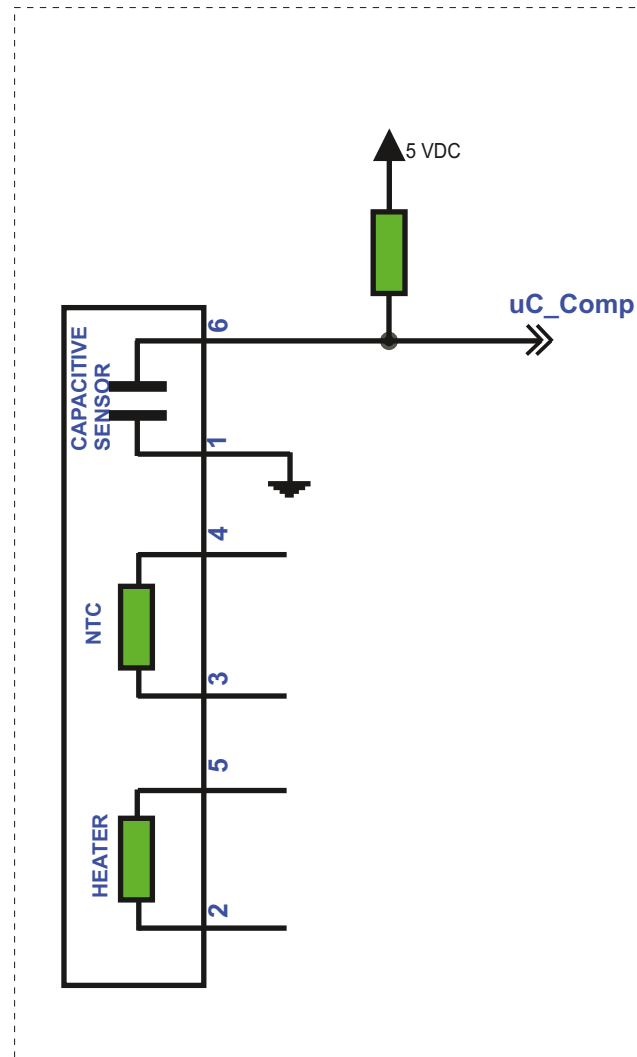

Picture 2

RAIN SENSOR - Application

To make the temperature measure you can use the following schematics:

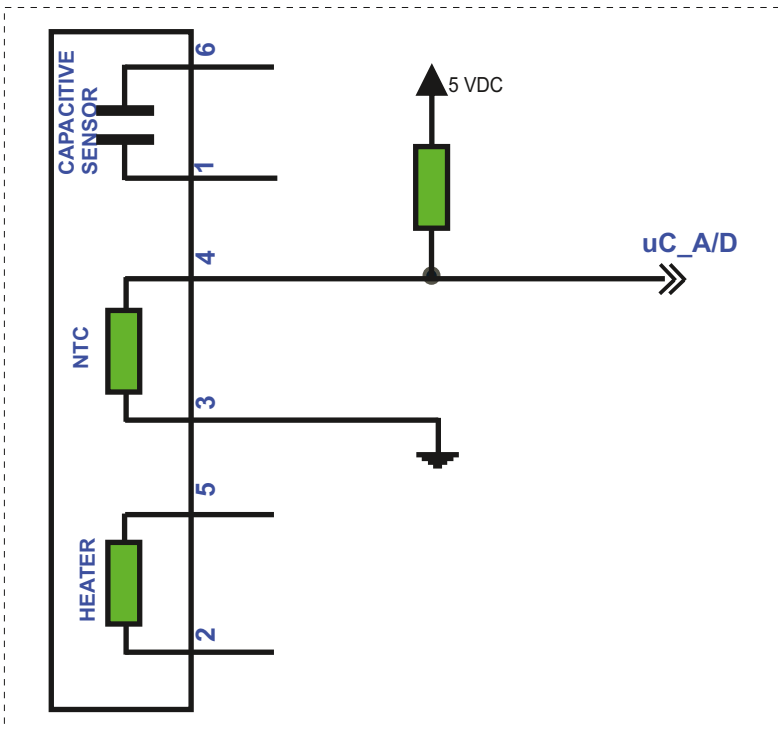

To drive the HEADER measure you can use the following schematics:

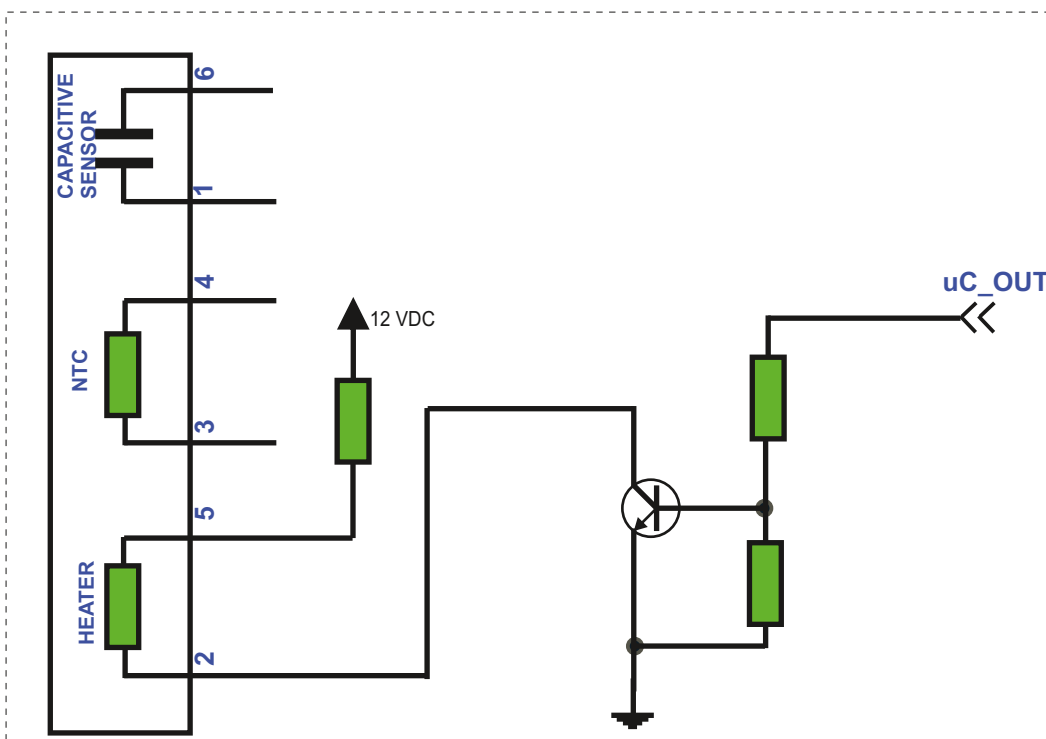

It's necessary a low cost NPN transistor with $I_C < 500\text{mA}$ / $V_{CE} < 25\text{V}$ for 12Volt standard bus voltage.

The nominal resistance is 42 Ohm .