

WIRING DIAGRAM

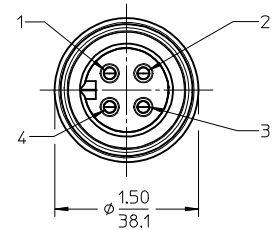
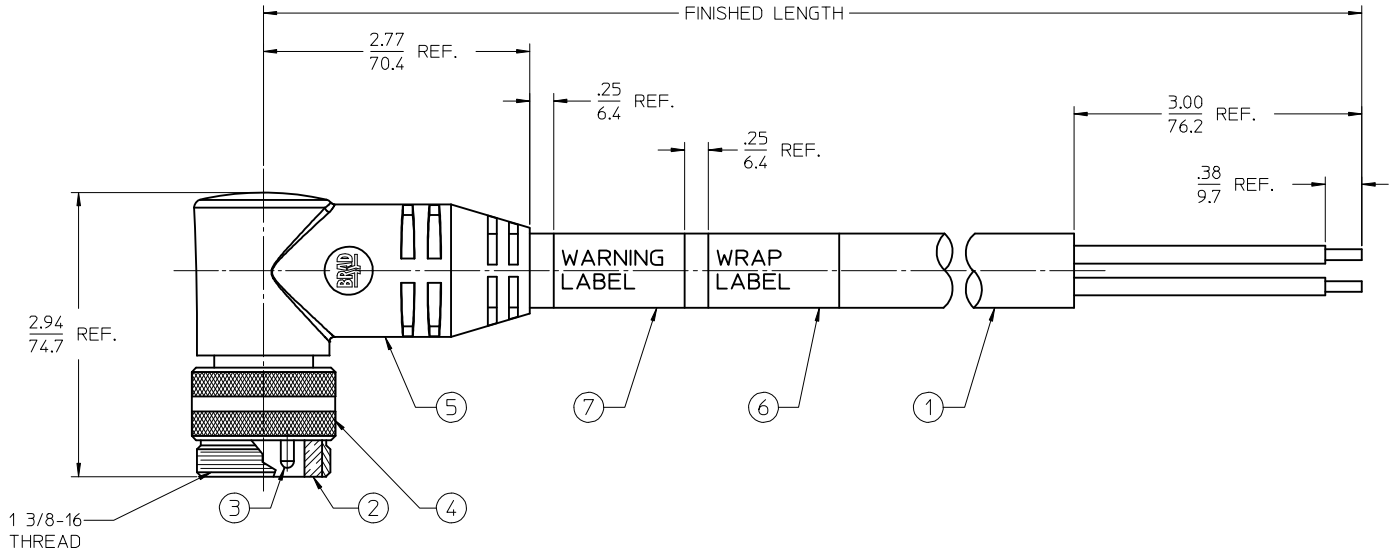

MALE FACE VIEW

NOTES:

- 1) MATERIAL: SEE TABLE
- 2) FINISHES: SEE TABLE
- 3) WRAP LABEL IS MARKED WITH P/N, DATE CODE VOLTAGE & AMPERAGE
- 4) MATES WITH: QUICK CHANGE 4 POLE RECEPTACLE
- 5) ELECTRICAL DATA:  
 10AWG UL TYPE: TC-ER STRANDED CABLE  
 MAX VOLTAGE: 600V  
 MAX CURRENT: 32A  
 PROTECTION IP67 (WHEN MATED)  
 TEMPERATURE RANGE: -20°C TO 90°C
- 6) PACKAGING:  
 CABLE ASSEMBLIES ARE BAGGED SEPERATLY IN POLY BAGS WITH BAR CODE LABEL ATTACHED TO OUTSIDE OF BAG.
- 7) ASSEMBLY IS RoHS COMPLIANT

PART NUMBER LEGEND

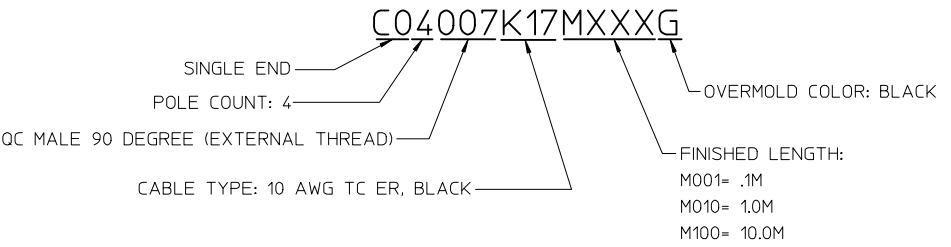

7	1	WARNING LABEL	VINYL	ORANGE/BLACK
6	1	WRAP LABEL	VINYL	BLACK/YELLOW
5	1	OVERMOLD	PVC	BLACK
4	1	COUPLING	ALUMINUM	CLEAR ANODIZE
3	4	CONTACT PIN	Cu ALLOY	GOLD PLATED
2	1	INSERT	PVC	BLACK
1	1	CABLE, 10/3 TC-ER (SEE NOTE 5)	TPE JACKET	BLACK
ITEM	QTY.	DESCRIPTION	MATERIAL	FINISH

RELEASED	EC NO: IPG2016-0989	2016/01/29
DRWNR:STONE	2016/01/29	
CHKD:		
APPR: BWOODMAN	2016/03/25	
DESCRIPTION		

QUALITY SYMBOLS	GENERAL TOLERANCES (UNLESS SPECIFIED)
▽=0	
▽=0	
	ANGULAR ± 1°
	DRAFT WHERE APPLICABLE MUST REMAIN WITHIN DIMENSIONS

DIMENSION STYLE	SCALE	DESIGN UNITS
IN/MM	1:1	INCH
DRAWN BY	DATE	TITLE
RSTONE	2016/01/29	QUICK CHANGE 4 POLE MALE 90 DEG 10/4 TPE BLACK
CHECKED BY	DATE	
APPROVED BY	DATE	
BWOODMAN	2016/03/25	
MATERIAL NO.	DOCUMENT NO.	SHEET NO.
-	SD-130063-098	1 OF 1

THIRD ANGLE PROJECTION	
THIS DRAWING CONTAINS INFORMATION THAT IS PROPRIETARY TO MOLEX INCORPORATED AND SHOULD NOT BE USED WITHOUT WRITTEN PERMISSION	