

PRODUCT NUMBER	DIM "A"	DIM "B"	APPLICATION
78628-001	.860 [21.84]	.300 [7.62]	E.S.D., SEE SHT. 4
78628-001LF	.860 [21.84]	.300 [7.62]	E.S.D., SEE SHT. 4
78628-002	.775 [19.68]	.380 [9.65]	MECH., SEE SHT. 2&3
78628-002LF	.775 [19.68]	.380 [9.65]	MECH., SEE SHT. 2&3

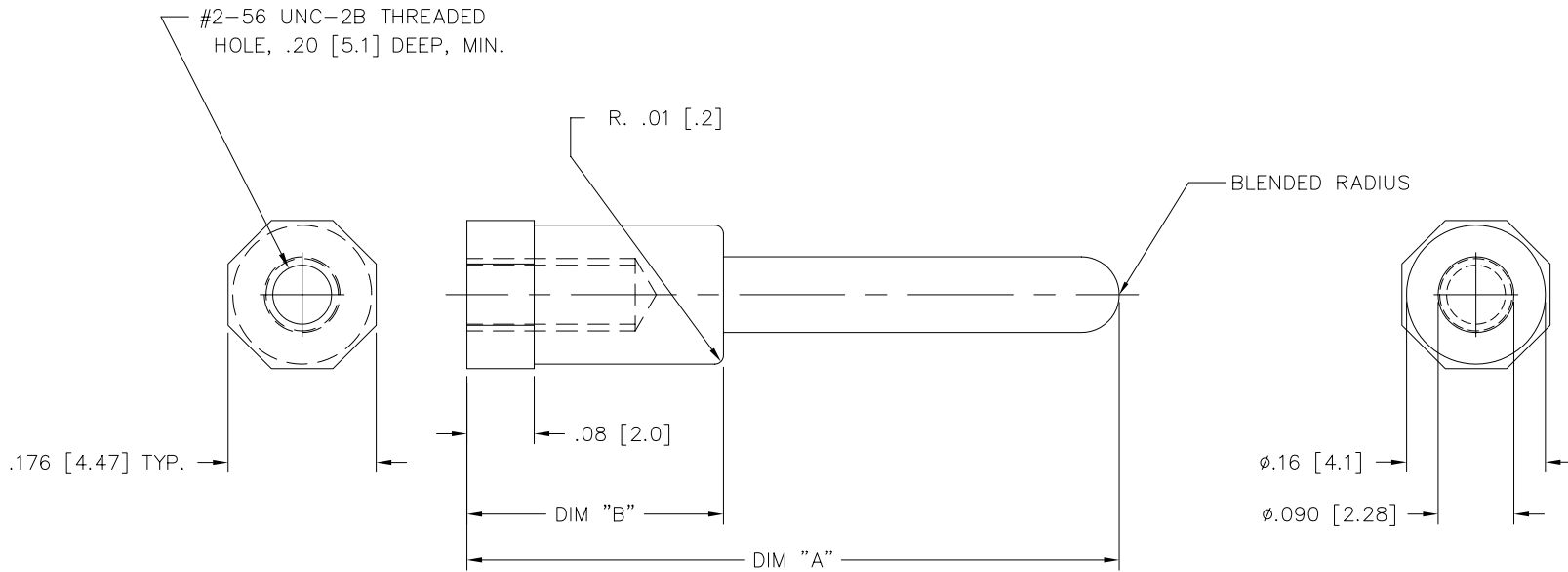

NOTES:

- ① MATERIAL: AISI 416 STAINLESS STEEL.
2. THIS PRODUCT WITH AN LF SUFFIX MEETS EUROPEAN UNION DIRECTIVES AND OTHER COUNTRY REGULATIONS AS DESCRIBED IN GS-22-008.
3. THIS PRODUCT IS NOT INTENDED TO BE EXPOSED TO MANUFACTURING SOLDER PROCESSES.

mat'l. code				surface		tolerance		projection		product family	
NOTE 1				ISO 1302 ✓		ISO 406 ISO 1101				HPC	
ltr	ecn no	dr	date	tolerances unless otherwise specified						title	
B	V31851	GIP	11/11/93	angles	.XX±.01/.3		INCH/MM		END MOUNTED GUIDE PIN		
C	V40690	RMP	3/29/94	linear	.xxx±.005/.13		scale 1:1		dwg no		
D	V00719	LSS	4/6/00	0°±2'	.xxxx±.0020/.051				sheet 1 of 4 size		
E	V05-0974	LP	10/31/05	dr	L.SANDERS	4/6/00			78628		
F	M06-0260	MHT	7/07/06	enr	M.GRAY	4/6/00			A3		
				chr	M.GRAY	4/6/00			type Product Customer Drawing		
				appd	M.GRAY	4/6/00					
sheet index	revision	F									
	sheet	1									

PRODUCT NO.
78628-002
78628-002LF

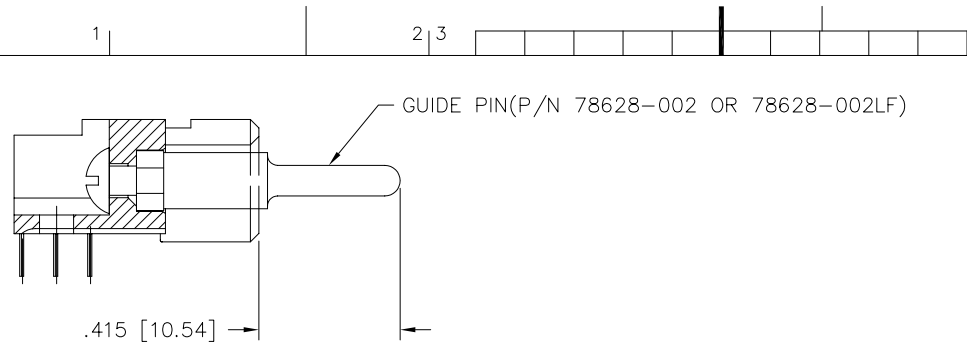

GUIDE PIN, MOUNTED TO RECPT.

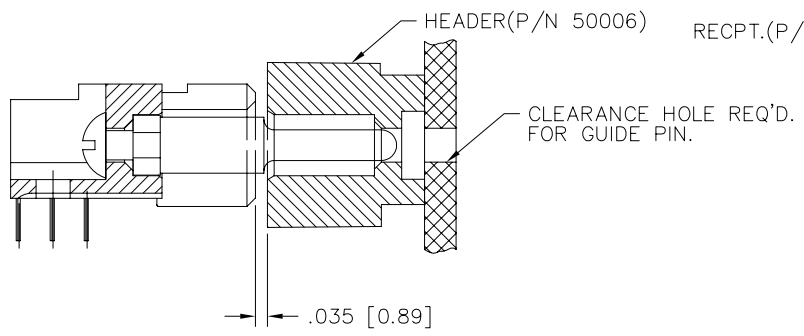

GUIDE PIN FIRST CONTACT

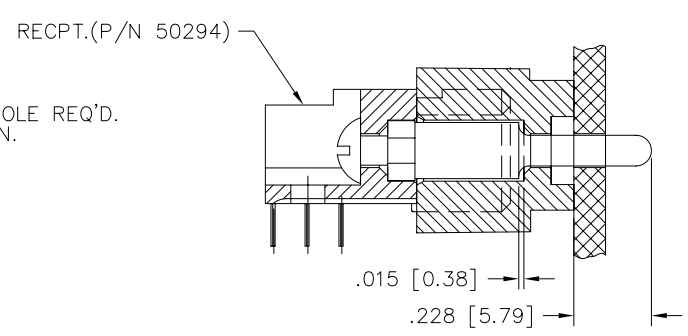

HOUSING FULLY MATED

END MOUNTED GUIDE PIN ON RECEPTACLE
(MECHANICAL)

NOTES:
1. P/N 78628-002 / 78628-002LF TO BE USED IN MECHANICAL APPLICATIONS ONLY, IT CAN BE MOUNTED IN RECPT. OR HEADERS, DESIGNED TO MAKE FIRST CONTACT WHEN HOUSING FACES ARE .035" APART.

mat'l. code		surface ISO 1302 ✓		tolerance ISO 406 ISO 1101		projection ⊕		product family HPC		
ltr	ecn	no	dr	date		tolerances unless otherwise specified		title		
F						.XX±.01/.3		END MOUNTED GUIDE PIN		
						linear .XXX±.005/.13		INCH/MM		
						0'±2'		scale 1:1		
						.XXX±.0020/.051		dwg no		
						dr L.SANDERS 4/6/00		sheet 2 of 4 size		
						enr M.GRAY 4/6/00		78628 A3		
						chr M.GRAY 4/6/00		type Product Customer Drawing		
						appd M.GRAY 4/6/00				
sheet	revision									
index	sheet									

Copyright FCJ
FCJconnect.com

PRODUCT NO.
78628-002
78628-002LF

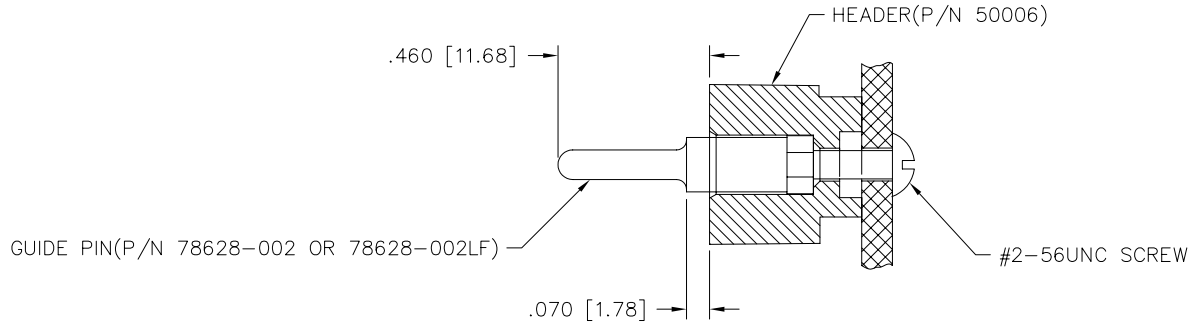

GUIDE PIN, MOUNTED TO HEADER

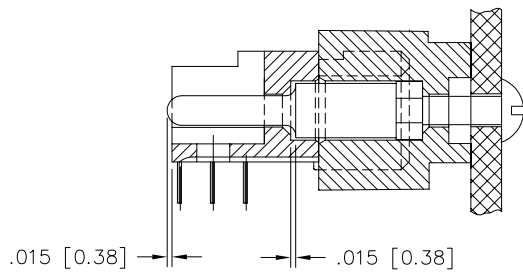

HOUSING FULLY MATED

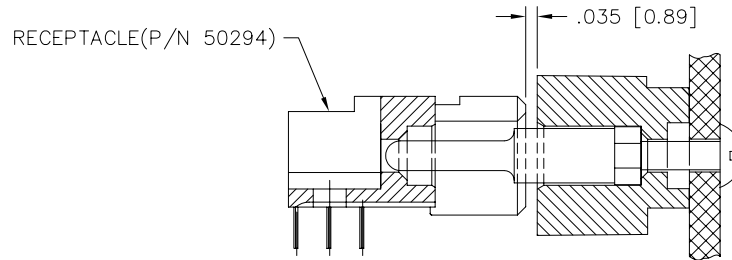

GUIDE PIN FIRST CONTACT

END MOUNTED GUIDE PIN ON HEADER
(MECHANICAL)

NOTES:

1. P/N 78628-002 / 78628-002LF TO BE USED IN MECHANICAL APPLICATIONS ONLY, IT CAN BE MOUNTED IN RECEPT OR HEADERS, DESIGNED TO MAKE FIRST CONTACT WHEN HOUSING FACES ARE .035" APART.

mat'l. code		surface ISO 1302 ✓		tolerance ISO 406 ISO 1101		projection ⊕		product family HPC	
ltr	ecn	no	dr	date		tolerances unless otherwise specified		title	
F						angles	linear	.XX±.01/.3	INCH/MM
						0'±2'		.xxx±.005/.13	
								.xxxx±.0020/.051	
				dr		L.SANDERS		4/6/00	
				enr		M.GRAY		4/6/00	
				chr		M.GRAY		4/6/00	
				appd		M.GRAY		4/6/00	
sheet index		revision sheet							



dwg no 78628 sheet 3 of 4 size A3
type Product Customer Drawing

FCJ
FCJconnect.com

Copyright FCJ

PRODUCT NO.
78628-001
78628-001LF

NOTES:

- P/N 78628-001 / 78628-001LF TO BE USED FOR ELECTRICAL DISCHARGE APPLICATIONS, MOUNTED IN HEADER ONLY. DESIGNED TO MAKE CONTACT WHEN HOUSING FACES ARE .060" APART.

mat'l. code		surface ISO 1302 <input checked="" type="checkbox"/>		tolerance ISO 406 ISO 1101		projection 		product family HPC			
ltr	ecn	no	dr	date	tolerances unless otherwise specified		title				
F					angles	linear	.XX±.01/.3	INCH/MM	END MOUNTED GUIDE PIN		
					0'±2'		.xxx±.005/.13				
							.xxx±.0020/.051	scale 1:1			
					dr	L.SANDERS	4/6/00		dwg no	sheet 4 of 4	size
					enr	M.GRAY	4/6/00		78628	A3	
					chr	M.GRAY	4/6/00				
					appd	M.GRAY	4/6/00		type	Product Customer Drawing	
sheet index	revision sheet										