

LOC		DIST		REVISIONS			
CM	00	F	LTR	DESCRIPTION	DATE	DMN	APVD
		F		REVISED PER ECO-12-016926	04OCT12	KH	SM
		F1		ECR-12-016748	30AUG13	M.T	D.Z

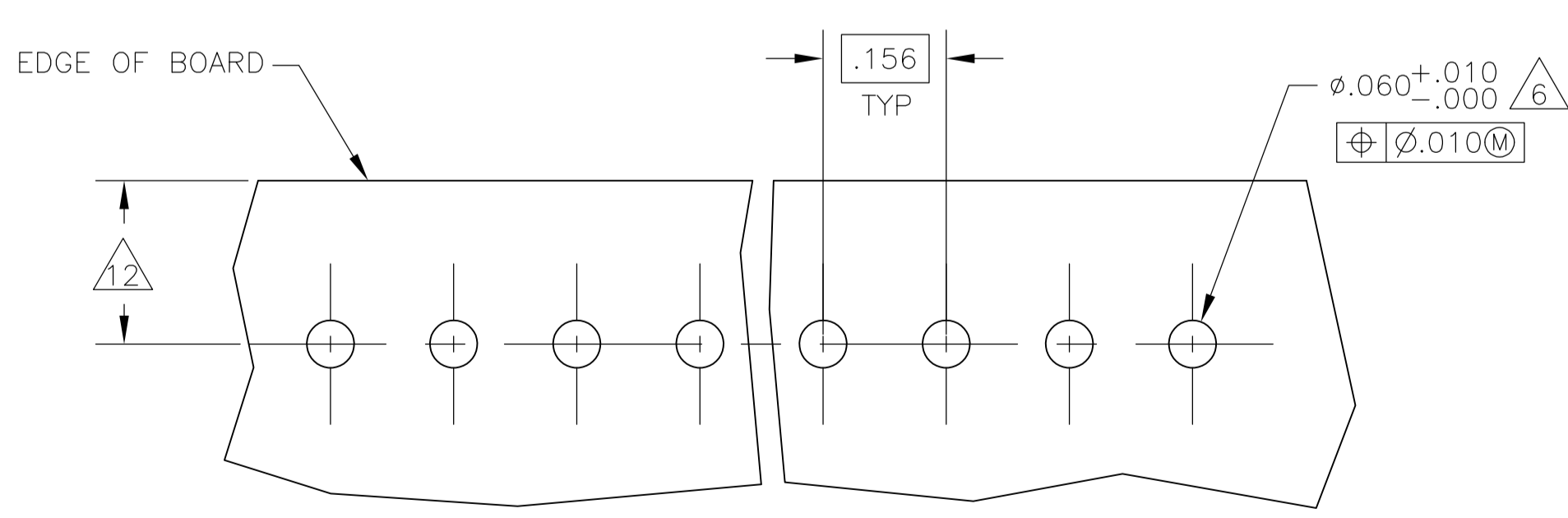
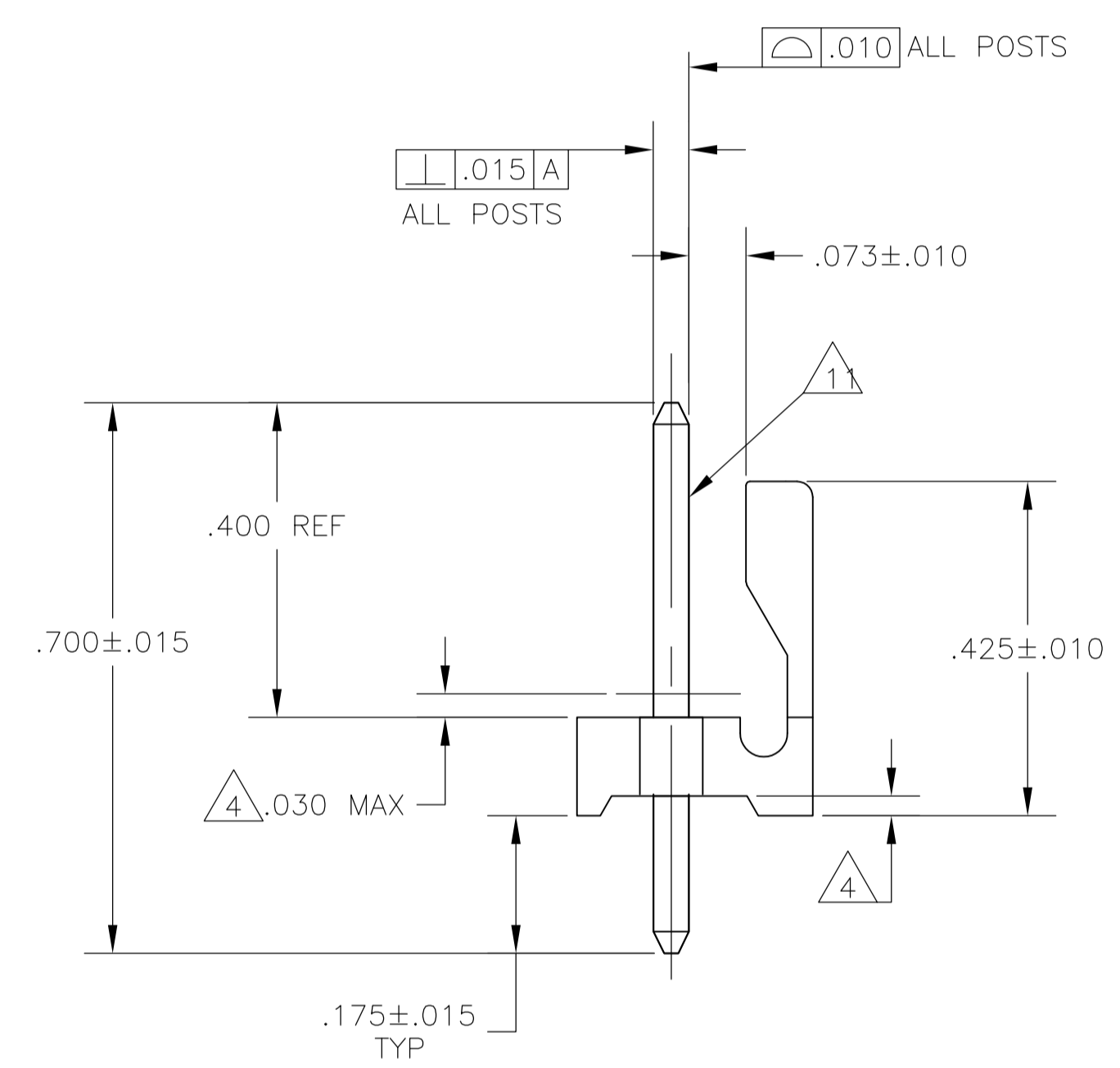
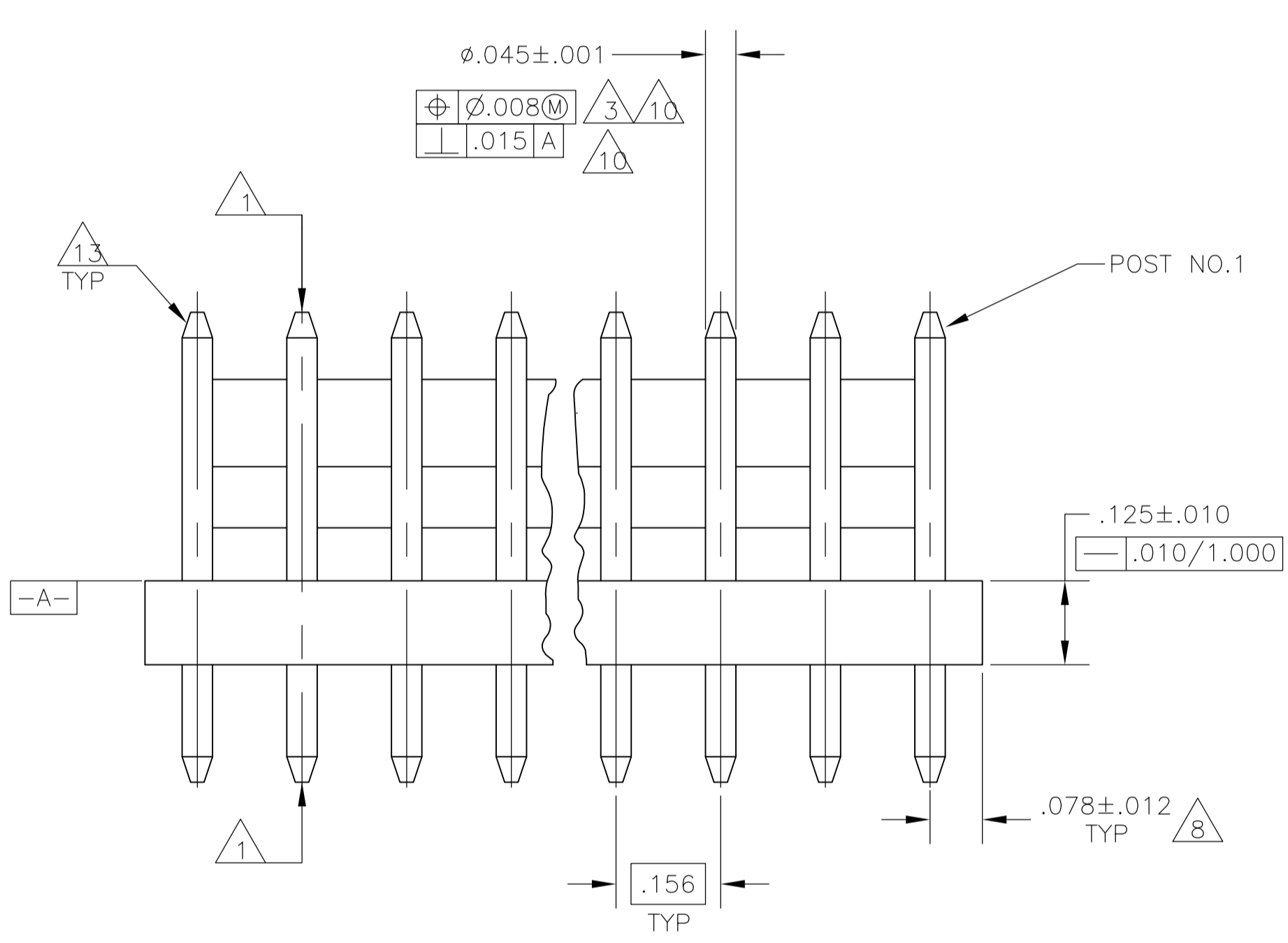
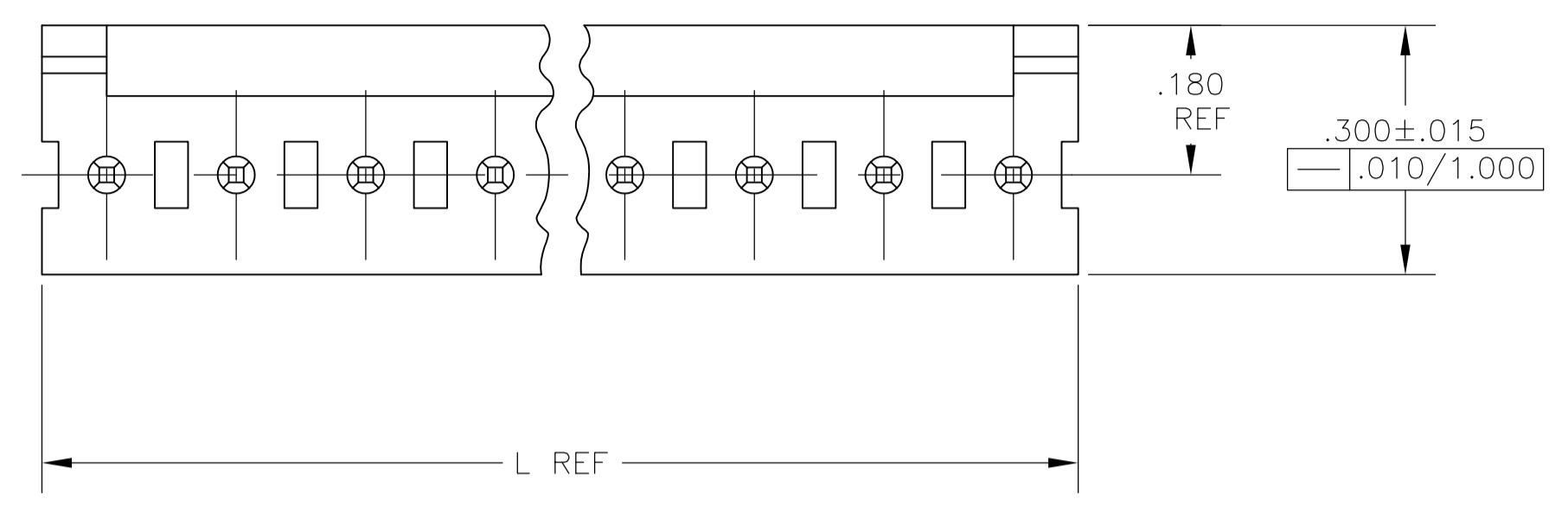

[IN]	MM	[IN]	MM
.060	1.52	1.000	25.40
.051	1.30	.750	19.05
.046	1.17	.450	11.43
.045	1.14	.425	10.80
.030	0.76	.300	7.62
.015	0.38	.180	4.57
.012	0.30	.175	4.45
.010	0.25	.156	3.96
.008	0.20	.125	3.18
.005	0.13	.078	1.98
.003	0.08	.073	1.85
.001	0.03	.068	1.73
.000	0.00	.063	1.60
[IN]	MM	[IN]	MM

CONVERSION TABLE

(F1) RECOMMENDED MOUNTING HOLE PATTERN FOR .109 ± 0.016 THICK P.C. BOARD

- 1 POST TO WITHSTAND 13 NEWTONS (3LBS.) MIN. AXIAL FORCE IN BOTH DIRECTIONS SHOWN WITHOUT DISLODGING.
- 2 TOLERANCES APPLY TO SOLDER SIDE OF BOARD.
- 3 MEASURED AT SURFACE -A-
- 4 PLASTIC FLASH PERMITTED IN THIS AREA.
- 5 PARTS COMPLY WITH AMP SOLDERABILITY SPEC. NO. 109-11-2.
- 6 ONE HOLE MAY BE UNDERSIZED (.051/.046 DIA.) FOR ASSEMBLY RETENTION DURING WAVE SOLDERING.
- 7 MATERIAL: HEADER-THERMOPLASTIC POLYESTER GLASS-FILLED 94V-0 (NATURAL) POST-COPPER ALLOY (TIN PLATED)
- 8 COORDINATE DIMENSION APPLIES FROM CENTER OF ACTUAL FEATURE.
- 9 PLASTIC BURRS CAUSED BY CUT-OFF TOOLING ARE PERMITTED WITHIN THE MAXIMUM TOLERANCE ENVELOPE.
- 10 POST TO BE MEASURED WHEN STRIP IS HELD FLAT.
- 11 POST MUST WITHSTAND TWO 90° BENDS AGAINST EXTRUSION WITHOUT BREAKING.
- 12 DIMENSION SHOULD BE .175 MIN WHEN MATING WITH A MTA 156 CONNECTOR ASSEMBLY OR A SL-156 CONNECTOR ASSEMBLY.
- 13 PIN BURR OF .005 MAX. VERTICAL AND .003 MAX. HORIZONTAL PERMITTED AT POST TIPS ON BOTH ENDS.

95.10	3.744	24	2-644753-4
91.14	3.588	23	2-644753-3
87.17	3.432	22	2-644753-2
83.21	3.276	21	2-644753-1
79.25	3.120	20	2-644753-0
75.29	2.964	19	1-644753-9
71.32	2.808	18	1-644753-8
67.36	2.652	17	1-644753-7
63.40	2.496	16	1-644753-6
59.44	2.340	15	1-644753-5
55.47	2.184	14	1-644753-4
51.51	2.028	13	1-644753-3
47.55	1.872	12	1-644753-2
43.59	1.716	11	1-644753-1
39.62	1.560	10	1-644753-0
35.66	1.404	9	644753-9
31.70	1.248	8	644753-8
27.74	1.092	7	644753-7
23.77	.936	6	644753-6
19.81	.780	5	644753-5
15.85	.624	4	644753-4
11.89	.468	3	644753-3
7.92	.312	2	644753-2
MM	[IN]	NUMBER OF POSITIONS	PART NUMBER

THIS DRAWING IS A CONTROLLED DOCUMENT.

DIMENSIONS: INCHES	TOLERANCES UNLESS OTHERWISE SPECIFIED:	0 PLC ± -	1 PLC ± -	2 PLC ± -	3 PLC ± .005	4 PLC ± -	ANGLES ± -
--------------------	----------------------------------------	-----------	-----------	-----------	--------------	-----------	------------

MATERIAL	FINISH	WEIGHT	SIZE	CAGE CODE	DRAWING NO	RESTRICTED TO
			A1		00779	

STE TE Connectivity

MTA-.156 HEADER ASSEMBLY, FRICTION LOCK, STRAIGHT .045 ROUND POST, TIN PLATED, SPECIAL

07NOV02
07NOV02
07NOV02

APVD: D. ROSSI
NAME: D. ROSSI

APPLICATION SPEC

CUSTOMER DRAWING SCALE: 5:1 SHEET 1 OF 1 REV F1