



LC78211, 78212, 78213

CMOS LSI

Analog Function Switch

ON Semiconductor®

<http://onsemi.com>

Applications

Function switching under serial data control in amplifiers, receivers, and other electronic equipment.

Features

- Two sets of eight (or in the LC78213, seven) built-in circuits with three switching configurations available based on differing internal connections.
- Control according to serial data sent from a microprocessor, and easy connection to 5 V microprocessors.
- Two identical products can be connected to a shared bus due to the provision of a select pin (S).
- A reset pin that turns off all analog switches.
- A ± 20 V withstand voltage rating allows these products to provide a wide dynamic range.

Specifications

Absolute Maximum Ratings at $T_a = 25^\circ\text{C}$

Parameter	Symbol	Conditions	Ratings	Unit
Maximum supply voltage	$V_{DD \text{ max}}$	V_{DD}	-0.3 to +20	V
	$V_{EE \text{ max}}$	V_{EE}	-20 to +0.3	V
Maximum input voltage	V_{I1}	DI, CL, CE, S, $\overline{\text{RES}}$	-0.3 to +20	V
	V_{I2}	L1 to L8, R1 to R8, LCOM1 to LCOM4, RCOM1 to RCOM4	$V_{EE} - 0.3$ to $V_{DD} + 0.3$	V
Analog switch potential difference when on	ΔV_{ON}	With the switch on	0.5	V
Allowable power dissipation	$P_d \text{ max}$	$T_a \leq 75^\circ\text{C}$	100	mW
Operating temperature range	T_{opr}		-30 to +75	$^\circ\text{C}$
Storage temperature range	T_{stg}		-40 to +125	$^\circ\text{C}$

Stresses exceeding those listed in the Maximum Ratings table may damage the device. If any of these limits are exceeded, device functionality should not be assumed, damage may occur and reliability may be affected.

Package Dimensions

unit : mm

PDIP30 / DIP30SD (400mil)

CASE 646AZ

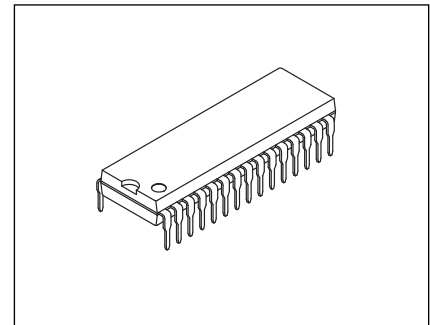
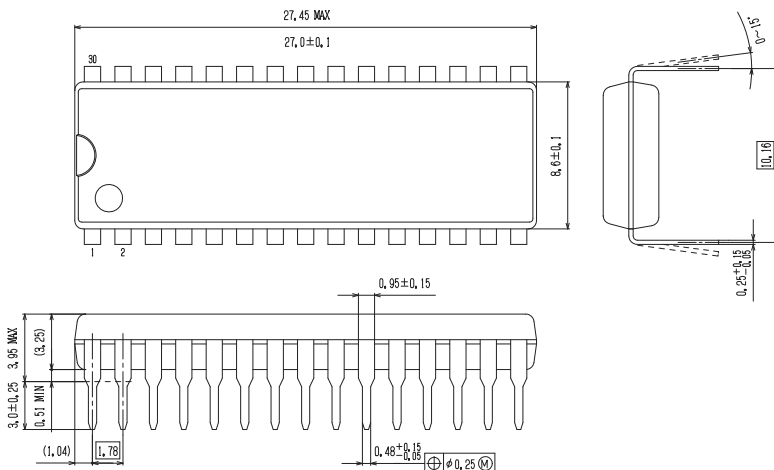

DIP30SD (400mil)

ORDERING INFORMATION

See detailed ordering and shipping information on page 6 of this data sheet.

Pin Assignments

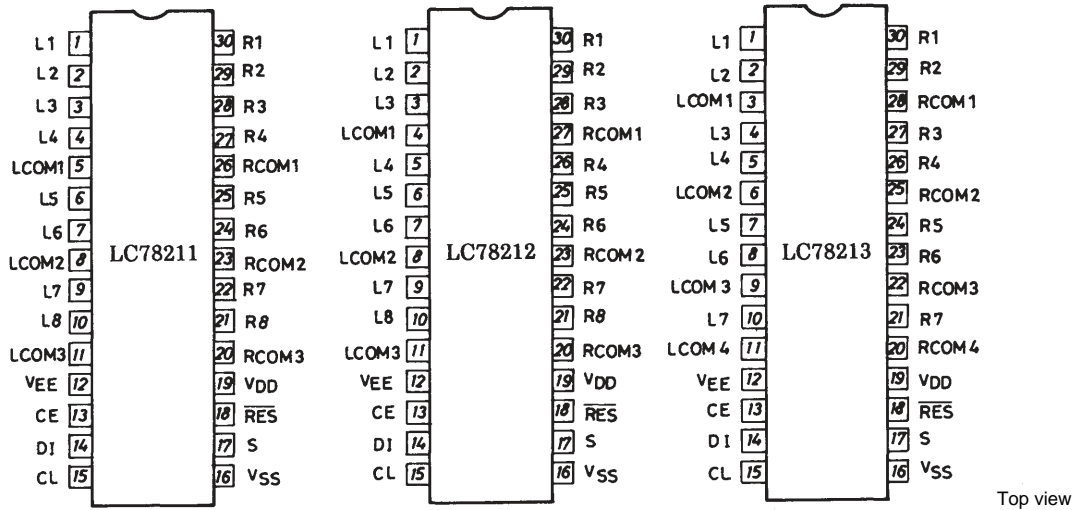

Top view

Allowable Operating Ranges at $T_a = 25^\circ\text{C}$, $V_{SS} = 0\text{ V}$, $|V_{DD}| \geq |V_{EE}|$

Parameter	Symbol	Conditions	min	typ	max	Unit
Maximum supply voltage	V_{DD}	$V_{DD} - V_{EE} \geq 12\text{ V}$; V_{DD}	6.0		18.5	V
	V_{EE}	$V_{DD} - V_{EE} \geq 12\text{ V}$; V_{EE}	-18.5		0	V
Input high level voltage	V_{IH1}	DI, CL, CE	4.0		18.5	V
	V_{IH2}	S, RES	$0.7 V_{DD}$		V_{DD}	V
Input low level voltage	V_{IL1}	DI, CL, CE	0		0.7	V
	V_{IL2}	S, RES	0		$0.3 V_{DD}$	V
Analog switch input voltage range	V_{IN}	L1 to L8, R1 to R8, LCOM1 to LCOM4, RCOM1 to RCOM4	V_{EE}		V_{DD}	V
Low level clock pulse width	$t_{\phi L}$	CL	0.5			μs
High level clock pulse width	$t_{\phi H}$	CL	0.5			μs
Setup time	$t_{\text{set up}}$	CL, DI	0.5			μs
	$t1^*$	CL, CE	0.5			μs
	$t2^*$	CL, CE	0.5			μs
	$t3^*$	CL, CE	0.5			μs
Minimum reset pulse width	t_{wRES}	$V_{DD} \geq 6\text{ V}$; $\overline{\text{RES}}$	1.0			μs
Hysteresis	V_H	CL, CE, DI	0.3			V

Note: * CE, CL and DI waveforms

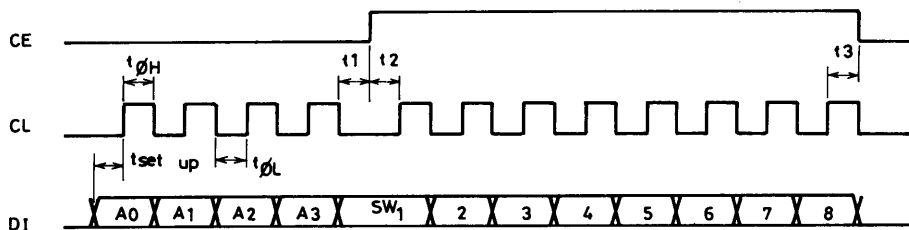

LC78211, 78212, 78213

Electrical Characteristics at $T_a = 25^\circ\text{C}$, $V_{SS} = 0\text{ V}$

Parameter	Symbol	Conditions	min	typ	max	Unit
Analog switch on resistance	R_{ON1}	$I = 1\text{ mA}$, $V_{DD} - V_{EE} = 12\text{ V}$: L1 to L8, R1 to R8, LCOM1 to LCOM4, RCOM1 to RCOM4		150		Ω
	R_{ON2}	$I = 1\text{ mA}$, $V_{DD} - V_{EE} = 37\text{ V}$: L1 to L8, R1 to R8, LCOM1 to LCOM4, RCOM1 to RCOM4		70		Ω
Total harmonic distortion	THD1	$V_{IN} = 1\text{ V}_{rms}$, $f = 1\text{ kHz}$, $V_{DD} - V_{EE} = 37\text{ V}$: L1 to L8, R1 to R8, LCOM1 to LCOM4, RCOM1 to RCOM4		0.0015	0.01	%
	THD2	$V_{IN} = 0.1\text{ V}_{rms}$, $f = 1\text{ kHz}$, $V_{DD} - V_{EE} = 37\text{ V}$: L1 to L8, R1 to R8, LCOM1 to LCOM4, RCOM1 to RCOM4		0.01	0.05	%
Feedthrough	F_{TH}	$V_{IN} = 0\text{ dBV}$, $f = 10\text{ kHz}$, $V_{DD} - V_{EE} = 37\text{ V}$: L1 to L8, R1 to R8, LCOM1 to LCOM4, RCOM1 to RCOM4		55		dB
Crosstalk	CT	$V_{IN} = 0\text{ dBV}$, $f = 10\text{ kHz}$, $V_{DD} - V_{EE} = 37\text{ V}$: L1 to L8, R1 to R8, LCOM1 to LCOM4, RCOM1 to RCOM4		75		dB
Input high level current	I_{IH}	$V_I = 18.5\text{ V}$: DI, CL, CE, S, $\overline{\text{RES}}$			+10	μA
Input low level current	I_{IL}	$V_I = 0\text{ V}$: DI, CL, CE, S, RES	-10			μA
Analog switch leakage current (off state)	I_{OFF}	$V_I = V_{EE}$ to $V_{EE} + 37\text{ V}$: L1 to L8, R1 to R8, LCOM1 to LCOM4, RCOM1 to RCOM4	-10		+10	μA
Current drain	I_{DD}	V_{DD}			1.0	mA

Equivalent Circuit Block Diagrams

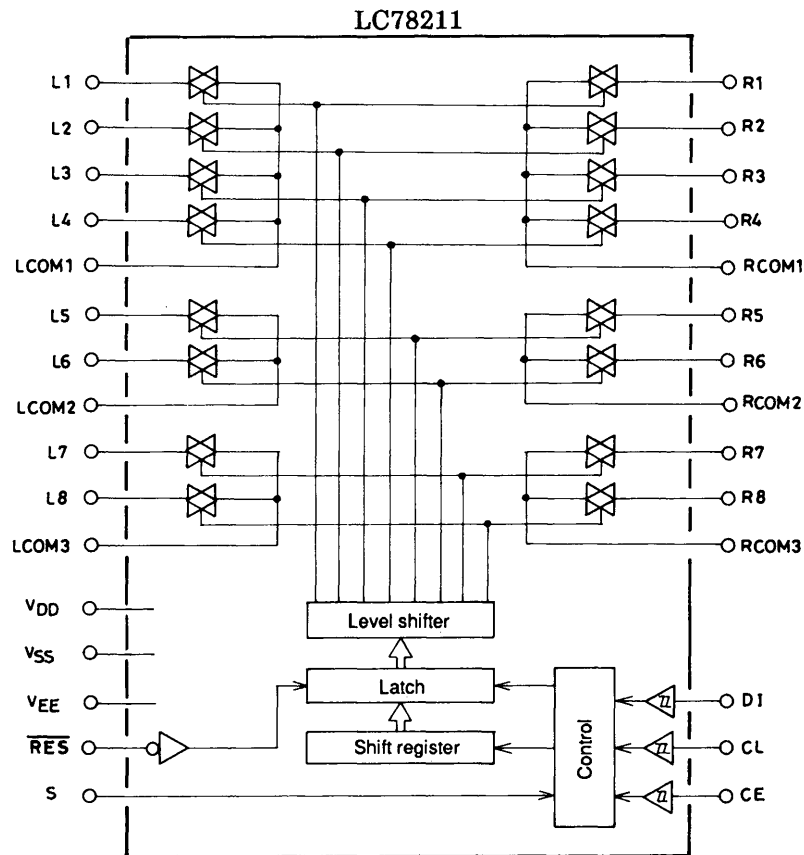

Continued on next page.

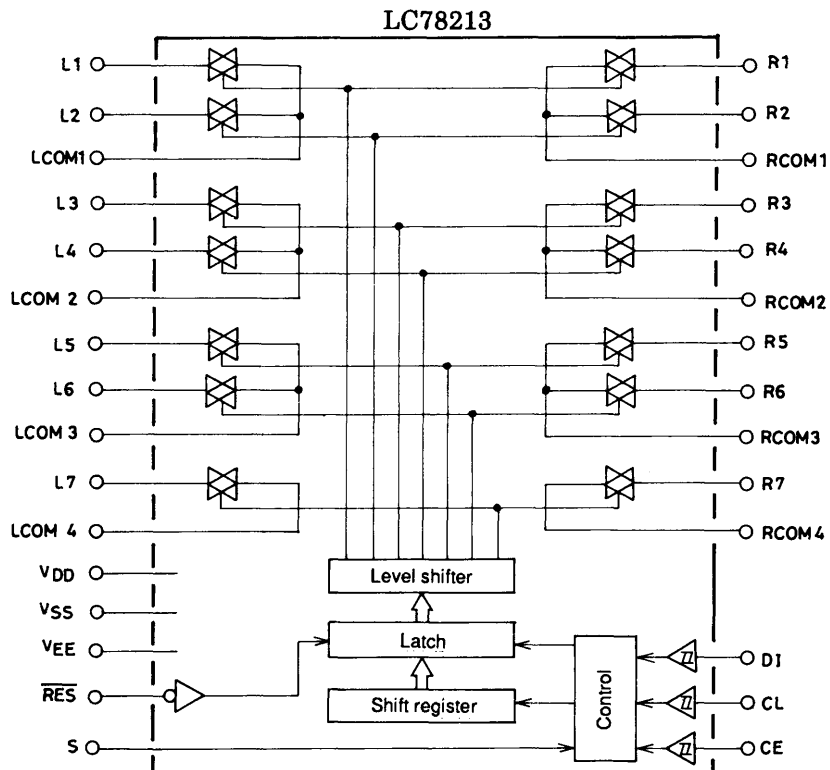
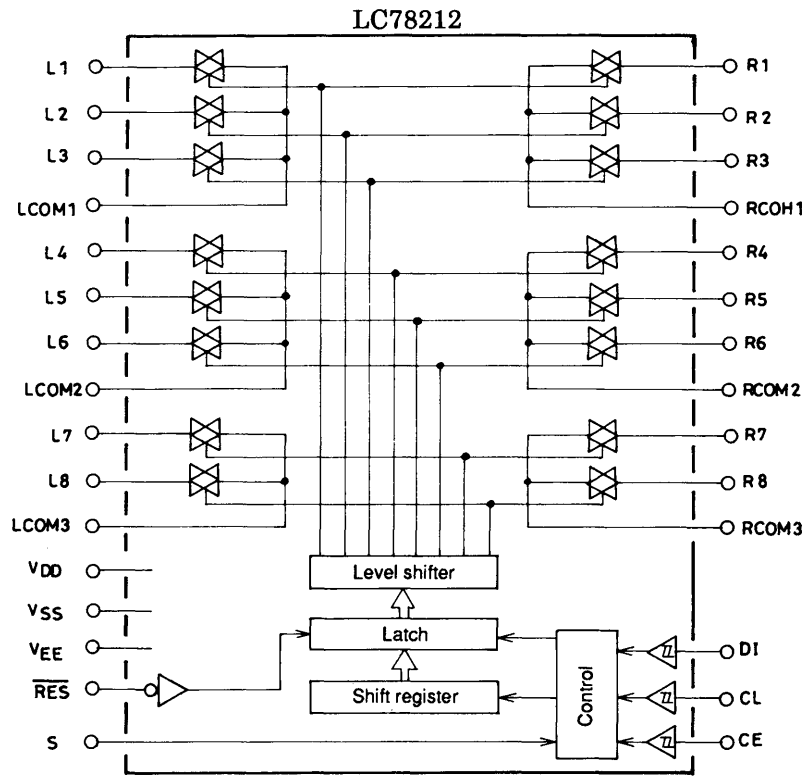

LC78211, 78212, 78213

Continued from preceding page.

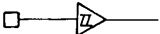

LC78211, 78212, 78213

Pin Functions

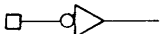
Pin	I/O	Internal equivalent circuit	Pin function																																											
V _{DD} , V _{SS} , V _{EE}			Power supply																																											
L1 to L8, R1 to R8, LCOM1 to LCOM4, RCOM1 to RCOM4		See the block diagram.	Analog switch input and output																																											
CL, DI, CE	I		Serial data input (Schmitt buffer) CLClock input DIData input CEChip enable																																											
S	I		Selection of one of two chips The address is set to the values shown in the table below according to the level input to the S pin. <table border="1" style="margin-left: 20px;"> <thead> <tr> <th rowspan="2">Product</th> <th rowspan="2">S pin level</th> <th colspan="4">Address</th> </tr> <tr> <th>A₀</th> <th>A₁</th> <th>A₂</th> <th>A₃</th> </tr> </thead> <tbody> <tr> <td rowspan="2">LC78211</td> <td>L</td> <td>0</td> <td>1</td> <td>0</td> <td>1</td> </tr> <tr> <td>H</td> <td>1</td> <td>1</td> <td>0</td> <td>1</td> </tr> <tr> <td rowspan="2">LC78212</td> <td>L</td> <td>0</td> <td>0</td> <td>1</td> <td>1</td> </tr> <tr> <td>H</td> <td>1</td> <td>0</td> <td>1</td> <td>1</td> </tr> <tr> <td rowspan="2">LC78213</td> <td>L</td> <td>0</td> <td>1</td> <td>1</td> <td>1</td> </tr> <tr> <td>H</td> <td>1</td> <td>1</td> <td>1</td> <td>1</td> </tr> </tbody> </table>	Product	S pin level	Address				A ₀	A ₁	A ₂	A ₃	LC78211	L	0	1	0	1	H	1	1	0	1	LC78212	L	0	0	1	1	H	1	0	1	1	LC78213	L	0	1	1	1	H	1	1	1	1
Product	S pin level	Address																																												
		A ₀	A ₁	A ₂	A ₃																																									
LC78211	L	0	1	0	1																																									
	H	1	1	0	1																																									
LC78212	L	0	0	1	1																																									
	H	1	0	1	1																																									
LC78213	L	0	1	1	1																																									
	H	1	1	1	1																																									
$\overline{\text{RES}}$	I		Reset input The states of the analog switches are undefined when power is first applied. Setting this pin low will force all switches the off state.																																											

Operation

1. Data Input Procedure

The LC78211, LC78212 and LC78213 are controlled by inputting specified data to the CL, DI and CE pins. The input data consists of 12 bits, of which four bits are address and eight bits are data.

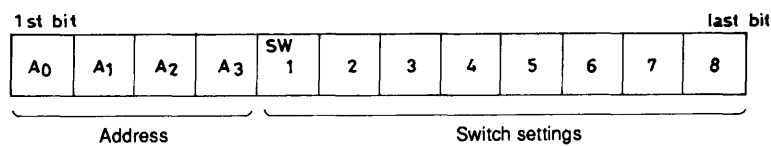

Bits correspond to the L1 to L8 and R1 to R8 analog switches, and a value of one turns the corresponding switch on, and a value of zero turns it off.

- 0Off
- 1On

The address is used when the chip is connected to a shared bus. The data (address) that must be transmitted depends on the S pin and the particular product as shown in the table below.

Product	S pin level	Address			
		A ₀	A ₁	A ₂	A ₃
LC78211	L	0	1	0	1
	H	1	1	0	1
LC78212	L	0	0	1	1
	H	1	0	1	1
LC78213	L	0	1	1	1
	H	1	1	1	1

Note: The bit for switch eight in the LC78213 is a “don’t care” bit, that is it can be either 0 or 1 without affecting chip function. This is because the LC78213 has two sets of seven (not eight) circuits.

LC78211, 78212, 78213

2. DI, CL and CE Timing

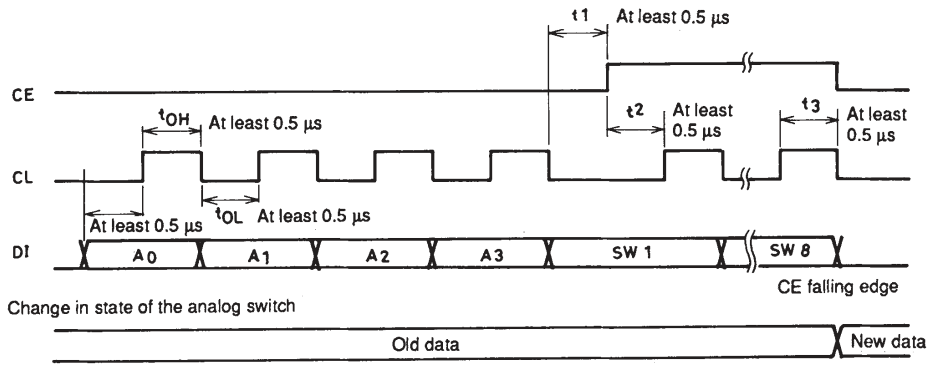

Data is read in on the rising edge of CL and latched on the falling edge of CE.

3. Notes on the Reset Pin

The states of the analog switches are undefined when power is first applied. However, it is possible to use the reset pin to force all switches to the off state by connecting an RC circuit to this pin.

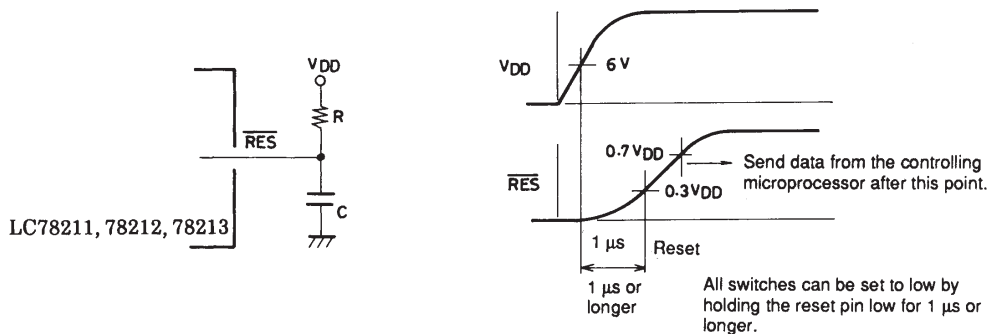

4. Using a CCB Bus with Multiple ICs

The LC78211, LC78212 and LC78213 retain their prior state until they receive data with a matching address.

5. Replacing Earlier Models

Caution is required when replacing an LC7821N, LC7823N and LC7823N with an LC78211, LC78212 and LC78213, since the S pin threshold levels differ.

6. Handling of Unused Input Pins

We recommend connecting any unused switch pin to V_{SS} through a resistor of up to a few 100 k to prevent damage from static electricity.

ORDERING INFORMATION

Device	Package	Shipping (Qty / Packing)
LC78211-E	DIP30SD(400mil) (Pb-Free / Halogen Free)	20 / Fan-Fold
LC78212-E	DIP30SD(400mil) (Pb-Free / Halogen Free)	20 / Fan-Fold
LC78213-E	DIP30SD(400mil) (Pb-Free / Halogen Free)	20 / Fan-Fold

ON Semiconductor and the ON logo are registered trademarks of Semiconductor Components Industries, LLC (SCILLC). SCILLC owns the rights to a number of patents, trademarks, copyrights, trade secrets, and other intellectual property. A listing of SCILLC's product/patent coverage may be accessed at www.onsemi.com/site/pdf/Patent-Marking.pdf. SCILLC reserves the right to make changes without further notice to any products herein. SCILLC makes no warranty, representation or guarantee regarding the suitability of its products for any particular purpose, nor does SCILLC assume any liability arising out of the application or use of any product or circuit, and specifically disclaims any and all liability, including without limitation special, consequential or incidental damages. "Typical" parameters which may be provided in SCILLC data sheets and/or specifications can and do vary in different applications and actual performance may vary over time. All operating parameters, including "Typicals" must be validated for each customer application by customer's technical experts. SCILLC does not convey any license under its patent rights nor the rights of others. SCILLC products are not designed, intended, or authorized for use as components in systems intended for surgical implant into the body, or other applications intended to support or sustain life, or for any other application in which the failure of the SCILLC product could create a situation where personal injury or death may occur. Should Buyer purchase or use SCILLC products for any such unintended or unauthorized application, Buyer shall indemnify and hold SCILLC and its officers, employees, subsidiaries, affiliates, and distributors harmless against all claims, costs, damages, and expenses, and reasonable attorney fees arising out of, directly or indirectly, any claim of personal injury or death associated with such unintended or unauthorized use, even if such claim alleges that SCILLC was negligent regarding the design or manufacture of the part. SCILLC is an Equal Opportunity/Affirmative Action Employer. This literature is subject to all applicable copyright laws and is not for resale in any manner.