



Low-Power, 13-Bit Voltage-Output DACs with Serial Interface

MAX535/MAX5351

General Description

The MAX535/MAX5351 combine a low-power, voltage-output, 13-bit digital-to-analog converter (DAC) and a precision output amplifier in an 8-pin μ MAX or DIP package. The MAX535 operates from a single +5V supply and the MAX5351 operates from a single +3.3V supply. Both devices draw only 280 μ A of supply current.

The output amplifier's inverting input is available to the user, allowing specific gain configurations, remote sensing, and high output current capability. This makes the MAX535/MAX5351 ideal for a wide range of applications, including industrial process control. Other features include a software shutdown and power-on reset.

The serial interface is compatible with either SPI™/QSPI™ or Microwire™. The DAC has a double-buffered input, organized as an input register followed by a DAC register. A 16-bit serial word loads data into the input register. The DAC register can be updated independently or simultaneously with the input register. All logic inputs are TTL/CMOS-logic compatible and buffered with Schmitt triggers to allow direct interfacing to optocouplers.

Applications

- Industrial Process Controls
- Automatic Test Equipment
- Digital Offset and Gain Adjustment
- Motion Control
- Remote Industrial Controls
- Microprocessor-Controlled Systems

Functional Diagram

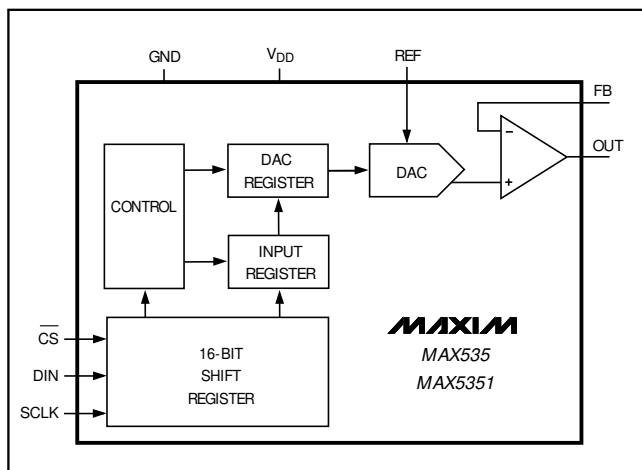

SPI and QSPI are registered trademarks of Motorola, Inc. Microwire is a registered trademark of National Semiconductor Corp.



Features

- ◆ 13-Bit DAC with Configurable Output Amplifier
- ◆ +5V Single-Supply Operation (MAX535)
+3.3V Single-Supply Operation (MAX5351)
- ◆ Low Supply Current: 0.24mA Normal Operation
2 μ A Shutdown Mode
- ◆ Available in 8-Pin μ MAX
- ◆ Power-On Reset Clears DAC Output to 0V
- ◆ SPI/QSPI and Microwire Compatible
- ◆ Schmitt-Trigger Digital Inputs for Direct Optocoupler Interface

Ordering Information

PART	TEMP. RANGE	PIN-PACKAGE	INL (LSB)
MAX535ACPA	0°C to +70°C	8 Plastic DIP	$\pm 1/2$
MAX535BCPA	0°C to +70°C	8 Plastic DIP	± 1
MAX535ACUA	0°C to +70°C	8 μ MAX†	$\pm 1/2$
MAX535BCUA	0°C to +70°C	8 μ MAX	± 1
MAX535BC/D	0°C to +70°C	Dice*	± 1

Ordering Information continued at end of data sheet.

† Contact factory for availability.

* Dice are tested at $T_A = +25^\circ\text{C}$, DC parameters only.

Pin Configuration

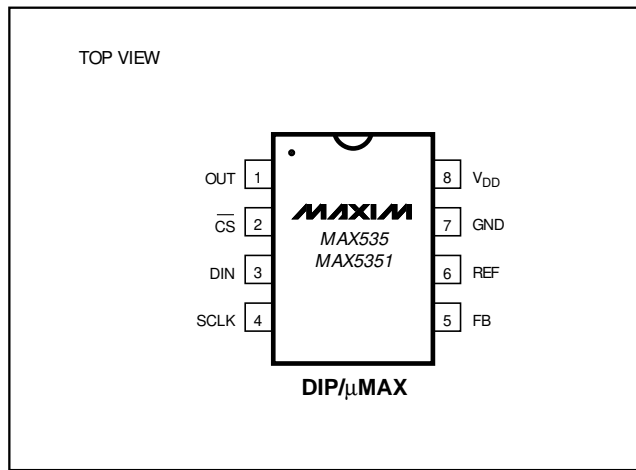

Low-Power, 13-Bit Voltage-Output DACs with Serial Interface

ABSOLUTE MAXIMUM RATINGS

V _{DD} to GND	-0.3V, +6V
REF, OUT, FB to GND	-0.3V to (V _{DD} + 0.3V)
Digital Inputs to GND	-0.3V to +6V
Continuous Current into Any Pin.....	±20mA
Continuous Power Dissipation (T _A = +70°C)	
Plastic DIP (derate 6.90mW/°C above +70°C)	552mW
μMAX (derate 4.00mW/°C above +70°C)	330mW
CERDIP (derate 8.00mW/°C above +70°C)	640mW

Operating Temperature Ranges

MAX535_C_A/MAX5351_C_A	0°C to +70°C
MAX535_E_A/MAX5351_E_A	-40°C to +85°C
MAX535BMJA/MAX5351BMJA	-55°C to +125°C
Storage Temperature Range	-65°C to +150°C
Lead Temperature (soldering, 10sec)	+300°C

Stresses beyond those listed under "Absolute Maximum Ratings" may cause permanent damage to the device. These are stress ratings only, and functional operation of the device at these or any other conditions beyond those indicated in the operational sections of the specifications is not implied. Exposure to absolute maximum rating conditions for extended periods may affect device reliability.

ELECTRICAL CHARACTERISTICS: MAX535

(V_{DD} = +5V ±10%, REF = 2.5V, GND = 0V, R_L = 5kΩ, C_L = 100pF, T_A = T_{MIN} to T_{MAX}, unless otherwise noted. Typical values are at T_A = +25°C. Output buffer connected in unity-gain configuration (Figure 8).)

PARAMETER	SYMBOL	CONDITIONS	MIN	TYP	MAX	UNITS
STATIC PERFORMANCE—ANALOG SECTION						
Resolution	N		13			Bits
Integral Nonlinearity (Note 1)	INL	MAX535A			±0.5	LSB
		MAX535B			±1.0	
		MAX535MJA			±2.0	
Differential Nonlinearity	DNL	Guaranteed monotonic			±1.0	LSB
Offset Error	V _{OS}			±0.3	±8	mV
Offset-Error Tempco	TCV _{OS}			6		ppm/°C
Gain Error (Note 1)	GE			-0.5	±6	LSB
Gain-Error Tempco				1		ppm/°C
Power-Supply Rejection Ratio	PSRR	4.5V ≤ V _{DD} ≤ 5.5V			600	μV/V
REFERENCE INPUT						
Reference Input Range	V _{REF}		0		V _{DD} - 1.4	V
Reference Input Resistance	R _{REF}	Code dependent, minimum at code 1555 hex	14	20		kΩ
MULTIPLYING-MODE PERFORMANCE						
Reference -3dB Bandwidth		V _{REF} = 0.67V _{p-p}		650		kHz
Reference Feedthrough		Input code = all 0s, V _{REF} = 3.6V _{p-p} at 1kHz		-84		dB
Signal-to-Noise Plus Distortion Ratio	SINAD	V _{REF} = 1V _{p-p} at 25kHz, code = full scale		77		dB
DIGITAL INPUTS						
Input High Voltage	V _{IH}		2.4			V
Input Low Voltage	V _{IL}				0.8	V
Input Leakage Current	I _{IN}	V _{IN} = 0V or V _{DD}		0.001	±0.5	μA
Input Capacitance	C _{IN}			8		pF

Low-Power, 13-Bit Voltage-Output DACs with Serial Interface

MAX535/MAX5351

ELECTRICAL CHARACTERISTICS: MAX535 (continued)

($V_{DD} = +5V \pm 10\%$, $REF = 2.5V$, $GND = 0V$, $R_L = 5k\Omega$, $C_L = 100pF$, $T_A = T_{MIN}$ to T_{MAX} , unless otherwise noted. Typical values are at $T_A = +25^\circ C$. Output buffer connected in unity-gain configuration (Figure 8).)

PARAMETER	SYMBOL	CONDITIONS	MIN	TYP	MAX	UNITS
DYNAMIC PERFORMANCE						
Voltage Output Slew Rate	SR			0.6		V/ μ s
Output Settling Time		To $\pm 1/2$ LSB, $V_{STEP} = 2.5V$		16		μ s
Output Voltage Swing		Rail-to-rail (Note 2)		0 to V_{DD}		V
Current into FB				0.001	± 0.1	μ A
Time to Valid Operation on Start-Up				20		μ s
Digital Feedthrough		$\overline{CS} = V_{DD}$, $DIN = 100kHz$		5		nV-s
POWER SUPPLIES						
Supply Voltage	V_{DD}		4.5		5.5	V
Supply Current	I_{DD}	(Note 3)		0.28	0.4	mA
Supply Current in Shutdown		(Note 3)		4	20	μ A
Reference Current in Shutdown				0.001	± 0.5	μ A
TIMING CHARACTERISTICS						
SCLK Clock Period	t_{CP}		100			ns
SCLK Pulse Width High	t_{CH}		40			ns
SCLK Pulse Width Low	t_{CL}		40			ns
\overline{CS} Fall to SCLK Rise Setup Time	t_{CSS}		40			ns
SCLK Rise to \overline{CS} Rise Hold Time	t_{CSH}		0			ns
DIN Setup Time	t_{DS}		40			ns
DIN Hold Time	t_{DH}		0			ns
SCLK Rise to \overline{CS} Fall Delay	t_{CS0}		40			ns
\overline{CS} Rise to SCLK Rise Hold Time	t_{CS1}		40			ns
\overline{CS} Pulse Width High	t_{CSW}		100			ns

Note 1: Guaranteed from code 22 to code 8191 in unity-gain configuration.

Note 2: Accuracy is better than 1LSB for $V_{OUT} = 8mV$ to $V_{DD} - 100mV$, guaranteed by a power-supply rejection test at the end points.

Note 3: $R_L = \infty$, digital inputs at GND or V_{DD} .

Low-Power, 13-Bit Voltage-Output DACs with Serial Interface

ELECTRICAL CHARACTERISTICS: MAX5351

($V_{DD} = +3.15V$ to $+3.6V$, $V_{REF} = 1.25V$, $GND = 0V$, $R_L = 5k\Omega$, $C_L = 100pF$, $T_A = T_{MIN}$ to T_{MAX} , unless otherwise noted. Typical values are at $T_A = +25^\circ C$. Output buffer connected in unity-gain configuration (Figure 8).)

PARAMETER	SYMBOL	CONDITIONS	MIN	TYP	MAX	UNITS
STATIC PERFORMANCE—ANALOG SECTION						
Resolution	N		13			Bits
Integral Nonlinearity (Note 4)	INL	MAX5351A			± 1	LSB
		MAX5351B			± 2	
		MAX5351MJA			± 4	
Differential Nonlinearity	DNL	Guaranteed monotonic			± 1.0	LSB
Offset Error	V_{OS}			± 0.3	± 8	mV
Offset-Error Tempco	TCV_{OS}			6		ppm/ $^\circ C$
Gain Error (Note 4)	GE			-0.5	± 6	LSB
Gain-Error Tempco				1		ppm/ $^\circ C$
Power-Supply Rejection Ratio	PSRR				600	$\mu V/V$
REFERENCE INPUT						
Reference Input Range	V_{REF}		0		$V_{DD} - 1.4$	V
Reference Input Resistance	R_{REF}	Code dependent, minimum at code 1555 hex	14	20		$k\Omega$
MULTIPLYING-MODE PERFORMANCE ($V_{DD} = +3.3V$)						
Reference -3dB Bandwidth		$V_{REF} = 0.67V_{p-p}$		650		kHz
Reference Feedthrough		Input code = all 0s, $V_{REF} = 1.9V_{p-p}$ at 1kHz		-84		dB
Signal-to-Noise Plus Distortion Ratio	SINAD	$V_{REF} = 1V_{p-p}$ at 25kHz, code = full scale		72		dB
DIGITAL INPUTS						
Input High Voltage	V_{IH}		2.4			V
Input Low Voltage	V_{IL}				0.6	V
Input Leakage Current	I_{IN}	$V_{IN} = 0V$ or V_{DD}		0.001	± 0.5	μA
Input Capacitance	C_{IN}			8		pF
DYNAMIC PERFORMANCE						
Voltage Output Slew Rate	SR			0.6		V/ μs
Output Settling Time		To $\pm 1/2LSB$, $V_{STEP} = 1.25V$		16		μs
Output Voltage Swing		Rail-to-rail (Note 5)		0 to V_{DD}		V
Current into FB				0.001	± 0.1	μA
Time to Valid Operation on Start-Up				20		μs
Digital Feedthrough		$\overline{CS} = V_{DD}$, $DIN = 100kHz$		5		nV-s
POWER SUPPLIES						
Supply Voltage	V_{DD}		3.15		3.6	V
Supply Current	I_{DD}	(Note 6)		0.24	0.4	mA
Supply Current in Shutdown		(Note 6)		1.6	10	μA
Reference Current in Shutdown				0.001	± 0.5	μA

Low-Power, 13-Bit Voltage-Output DACs with Serial Interface

MAX535/MAX5351

ELECTRICAL CHARACTERISTICS: MAX5351 (continued)

($V_{DD} = +3.15V$ to $+3.6V$, $REF = 1.25V$, $GND = 0V$, $R_L = 5k\Omega$, $C_L = 100pF$, $T_A = T_{MIN}$ to T_{MAX} , unless otherwise noted. Typical values are at $T_A = +25^\circ C$. Output buffer connected in unity-gain configuration (Figure 8).)

PARAMETER	SYMBOL	CONDITIONS	MIN	TYP	MAX	UNITS
TIMING CHARACTERISTICS						
SCLK Clock Period	t_{CP}		100			ns
SCLK Pulse Width High	t_{CH}		40			ns
SCLK Pulse Width Low	t_{CL}		40			ns
\overline{CS} Fall to SCLK Rise Setup Time	t_{CSS}		40			ns
SCLK Rise to \overline{CS} Rise Hold Time	t_{CSH}		0			ns
DIN Setup Time	t_{DS}		40			ns
DIN Hold Time	t_{DH}		0			ns
SCLK Rise to \overline{CS} Fall Delay	t_{CS0}		40			ns
\overline{CS} Rise to SCLK Rise Hold Time	t_{CS1}		40			ns
\overline{CS} Pulse Width High	t_{CSW}		100			ns

Note 4: Guaranteed from code 44 to code 8191 in unity-gain configuration.

Note 5: Accuracy is better than 1LSB for $V_{OUT} = 8mV$ to $V_{DD} - 150mV$, guaranteed by a power-supply rejection test at the end points.

Note 6: $R_L = \infty$, digital inputs at GND or V_{DD} .

Low-Power, 13-Bit Voltage-Output DACs with Serial Interface

Typical Operating Characteristics

(MAX535 only, $V_{DD} = +5V$, $R_L = 5k\Omega$, $C_L = 100pF$, $T_A = +25^\circ C$, unless otherwise noted.)

MAX535

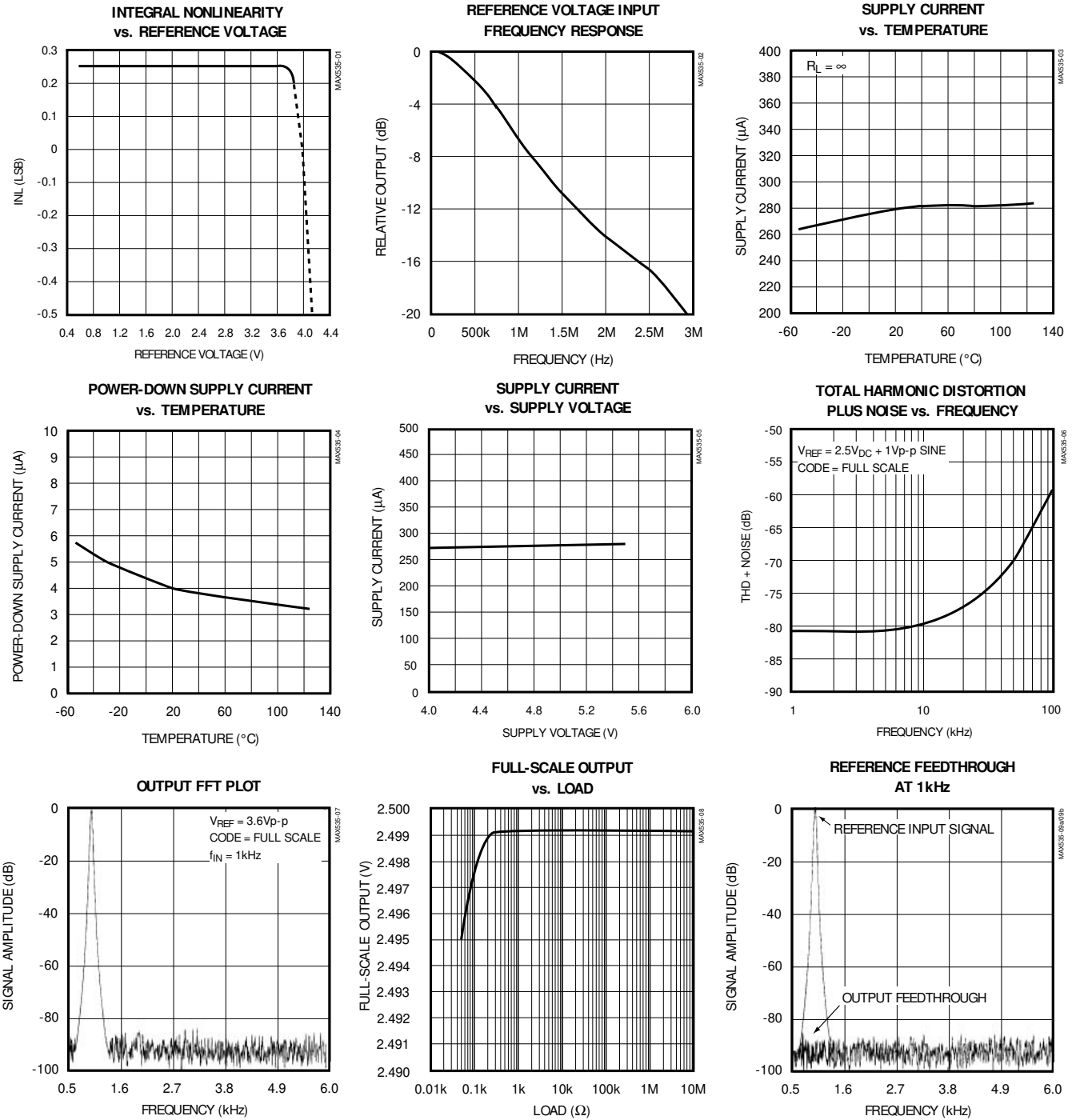

Low-Power, 13-Bit Voltage-Output DACs with Serial Interface

MAX535/MAX5351

Typical Operating Characteristics (continued)

(MAX535 only, $V_{DD} = +5V$, $R_L = 5k\Omega$, $C_L = 100pF$, $T_A = +25^\circ C$, unless otherwise noted.)

MAX535 (continued)

MAJOR-CARRY TRANSITION

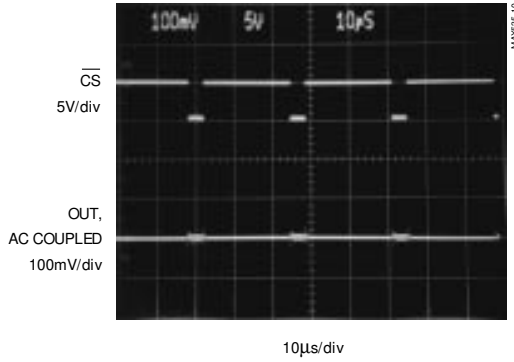

DIGITAL FEEDTHROUGH ($f_{SCLK} = 100kHz$)

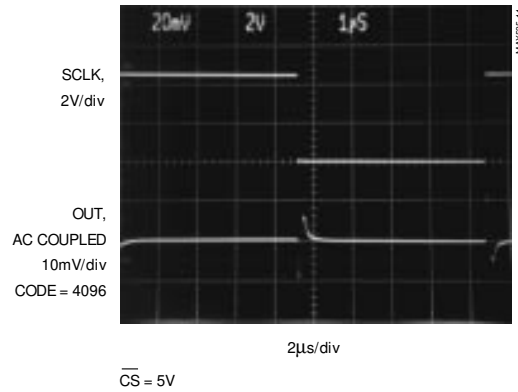

DYNAMIC RESPONSE

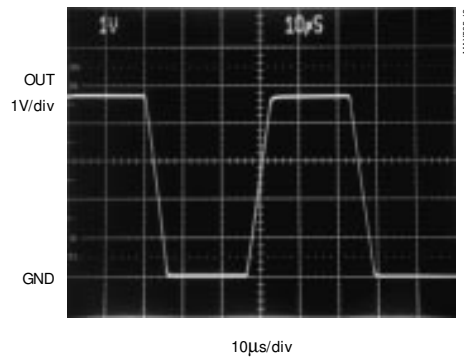

GAIN = 2, SWITCHING FROM CODE 0 TO 8040

Low-Power, 13-Bit Voltage-Output DACs with Serial Interface

Typical Operating Characteristics (continued)

(MAX5351 only, $V_{DD} = +3.3V$, $R_L = 5k\Omega$, $C_L = 100pF$, $T_A = +25^\circ C$, unless otherwise noted.)

MAX5351

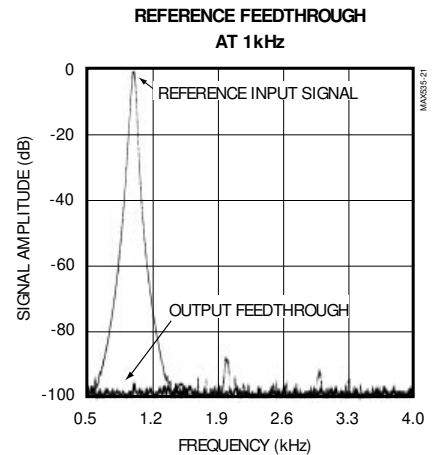
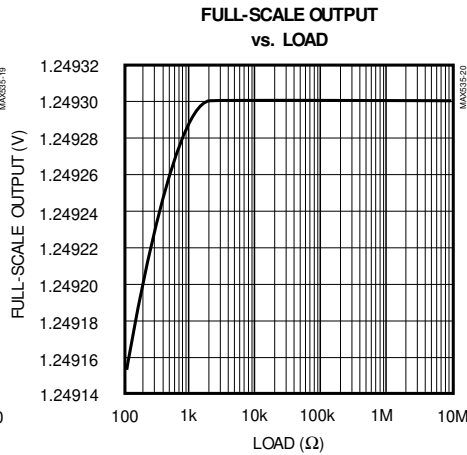
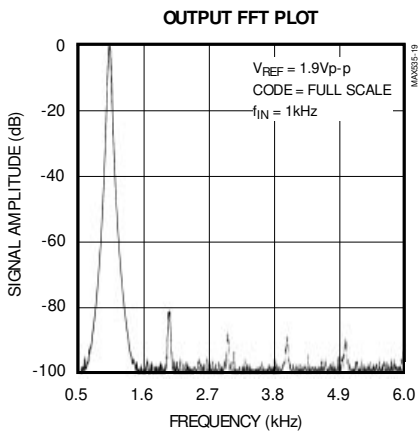
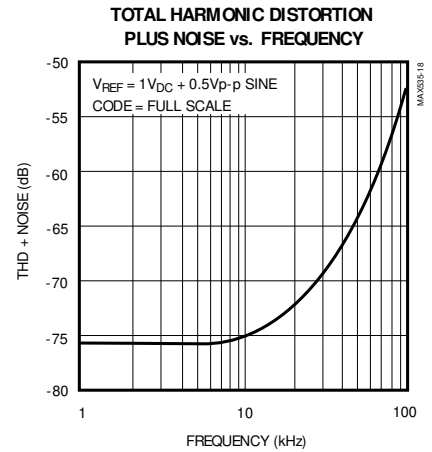
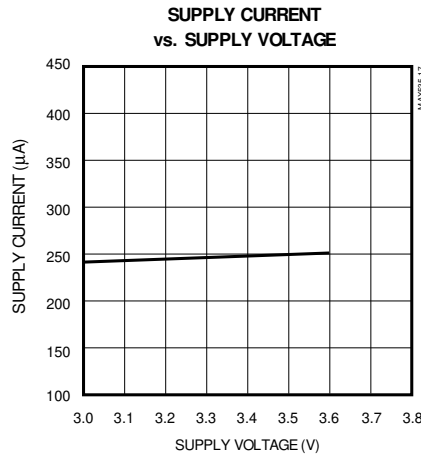
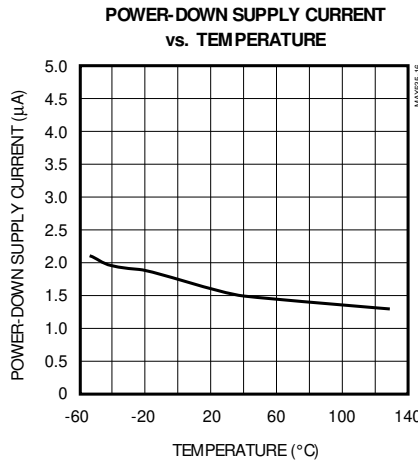
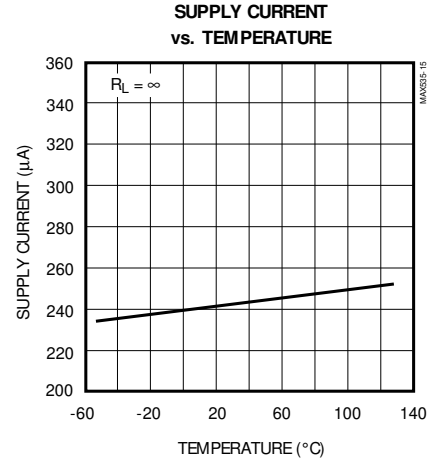
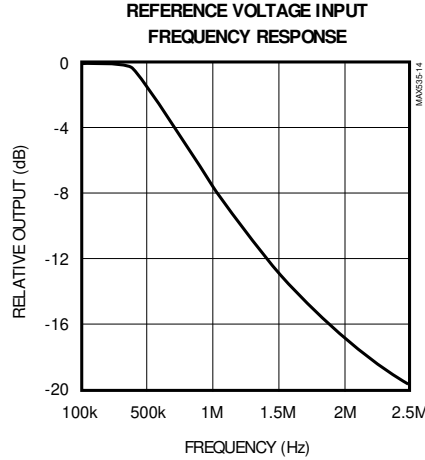
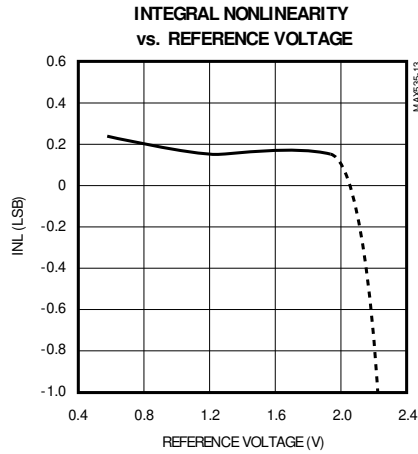

Low-Power, 13-Bit Voltage-Output DACs with Serial Interface

MAX535/MAX5351

Pin Description

PIN	NAME	FUNCTION
1	OUT	DAC Output Voltage
2	\overline{CS}	Chip-Select Input. Active low.
3	DIN	Serial-Data Input
4	SCLK	Serial-Clock Input
5	FB	DAC Output Amplifier Feedback
6	REF	Reference Voltage Input
7	GND	Ground
8	V _{DD}	Positive Power Supply

Detailed Description

The MAX535/MAX5351 contain a 13-bit, voltage-output digital-to-analog converter (DAC) that is easily addressed using a simple 3-wire serial interface. It includes a 16-bit shift register, and has a doubled-buffered input composed of an input register and a DAC register (see *Functional Diagram*). In addition to the voltage output, the amplifier's negative input is available to the user.

The DAC is an inverted R-2R ladder network that converts a 13-bit digital input into an equivalent analog output voltage in proportion to the applied reference voltage input. Figure 1 shows a simplified circuit diagram of the DAC.

Reference Inputs

The reference input accepts positive DC and AC signals. The voltage at the reference input sets the full-scale output voltage for the DAC. The reference input voltage range is 0V to (V_{DD} - 1.4V). The output voltage (V_{OUT}) is represented by a digitally programmable voltage source as:

$$V_{OUT} = (V_{REF} \times NB / 8192) \times \text{Gain}$$

where NB is the numeric value of the DAC's binary input code (0 to 8191), V_{REF} is the reference voltage, and Gain is the externally set voltage gain.

The impedance at the reference input is code dependent, ranging from a low value of 14kΩ when the DAC has an input code of 1555 hex, to a high value exceeding several giga ohms (leakage currents) with an input

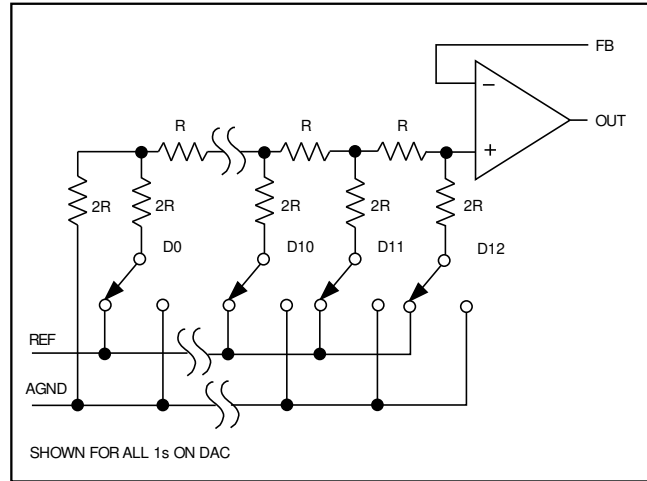

Figure 1. Simplified DAC Circuit Diagram

code of 0000 hex. Because the input impedance at the reference pin is code dependent, load regulation of the reference source is important.

The REF reference input has a 14kΩ guaranteed minimum input impedance. A voltage reference with a load regulation of 6ppm/mA, such as the MAX873, would typically deviate by 0.0062LSB (0.009LSB worst case) when driving the MAX535 reference input at 2.5V.

In shutdown mode, the MAX535/MAX5351's REF input enters a high-impedance state with a typical input leakage current of 0.001μA.

The reference input capacitance is also code dependent and typically ranges from 15pF (with an input code of all 0s) to 50pF (with an input code of all 1s).

Output Amplifier

The MAX535/MAX5351's DAC output is internally buffered by a precision amplifier with a typical slew rate of 0.6V/μs. Access to the output amplifier's inverting input provides the user greater flexibility in output gain setting/signal conditioning (see the *Applications Information* section).

With a full-scale transition at the MAX535/MAX5351 output, the typical settling time to ±1/2LSB is 16μs when loaded with 5kΩ in parallel with 100pF (loads less than 2kΩ degrade performance).

The MAX535 output amplifier's output dynamic responses and settling performances are shown in the *Typical Operating Characteristics*.

Low-Power, 13-Bit Voltage-Output DACs with Serial Interface

Shutdown Mode

The MAX535/MAX5351 feature a software-programmable shutdown that reduces supply current to a typical value of 4µA. Writing 111XXXXXXXXXXXX as the input-control word puts the MAX535/MAX5351 in shutdown mode (Table 1).

In shutdown mode, the MAX535/MAX5351 output amplifier and the reference input enter a high-impedance state. The serial interface remains active. Data in the input registers is retained in shutdown, allowing the MAX535/MAX5351 to recall the output state prior to entering shutdown. Exit shutdown mode by either recalling the previous configuration or by updating the DAC with new data. When powering up the device or bringing it out of shutdown, allow 20µs for the output to stabilize.

Serial-Interface Configurations

The MAX535/MAX5351's 3-wire serial interface is compatible with both Microwire™ (Figure 2) and SPI™/QSPI™ (Figure 3). The serial input word consists of three control bits followed by 13 data bits (MSB first), as shown in Figure 4. The 3-bit control code determines the MAX535/MAX5351's response outlined in Table 1.

The MAX535/MAX5351's digital inputs are double buffered. Depending on the command issued through the serial interface, the input register can be loaded without affecting the DAC register, the DAC register can be loaded directly, or the DAC register can be updated from the input register (Table 1).

Serial-Interface Description

The MAX535/MAX5351 require 16 bits of serial data. Table 1 lists the serial-interface programming commands. For certain commands, the 13 data bits are "don't cares." Data is sent MSB first and can be sent in two 8-bit packets or one 16-bit word (\overline{CS} must remain low until 16 bits are transferred). The serial data is composed of three control bits (C2, C1, C0), followed by the 13 data bits D12...D0 (Figure 4). The 3-bit control code determines:

- The register to be updated
- The configuration when exiting shutdown

Figure 5 shows the serial-interface timing requirements. The chip-select pin (\overline{CS}) must be low to enable the DAC's serial interface. When \overline{CS} is high, the interface control circuitry is disabled. \overline{CS} must go low at least t_{CSS} before the rising serial clock (SCLK) edge to properly clock in the first bit. When \overline{CS} is low, data is clocked into the internal shift register via the serial-data input pin (DIN) on SCLK's rising edge. The maximum guaranteed clock frequency is 10MHz. Data is latched into the MAX535/MAX5351 input/DAC register on \overline{CS} 's rising edge.

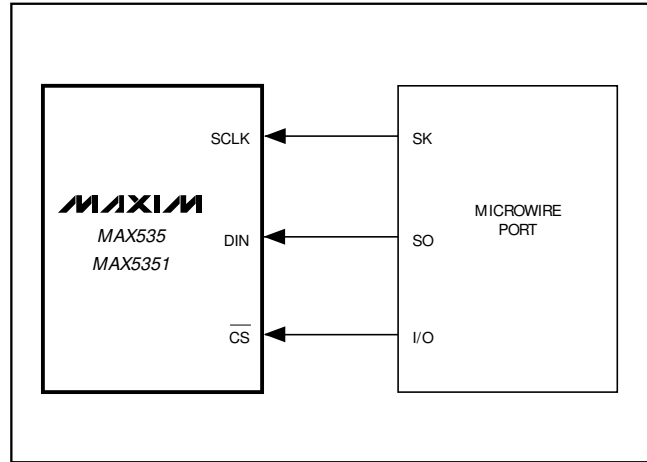

Figure 2. Connections for Microwire

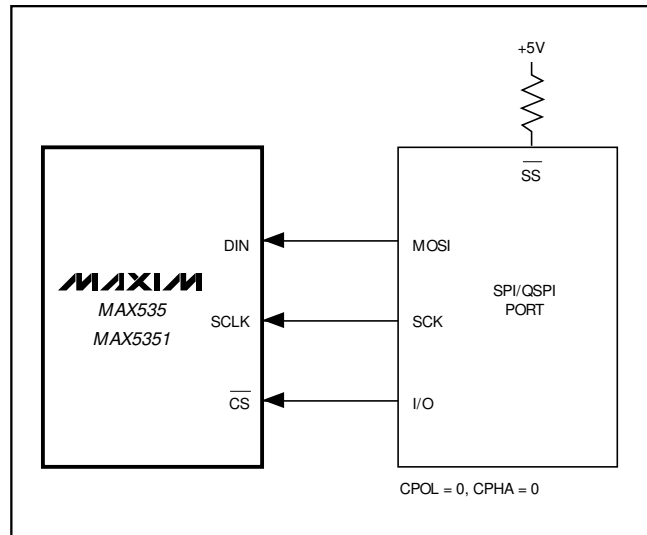

Figure 3. Connections for SPI/QSPI

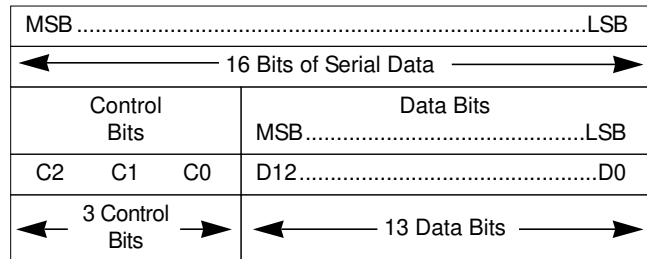

Figure 4. Serial-Data Format

Low-Power, 13-Bit Voltage-Output DACs with Serial Interface

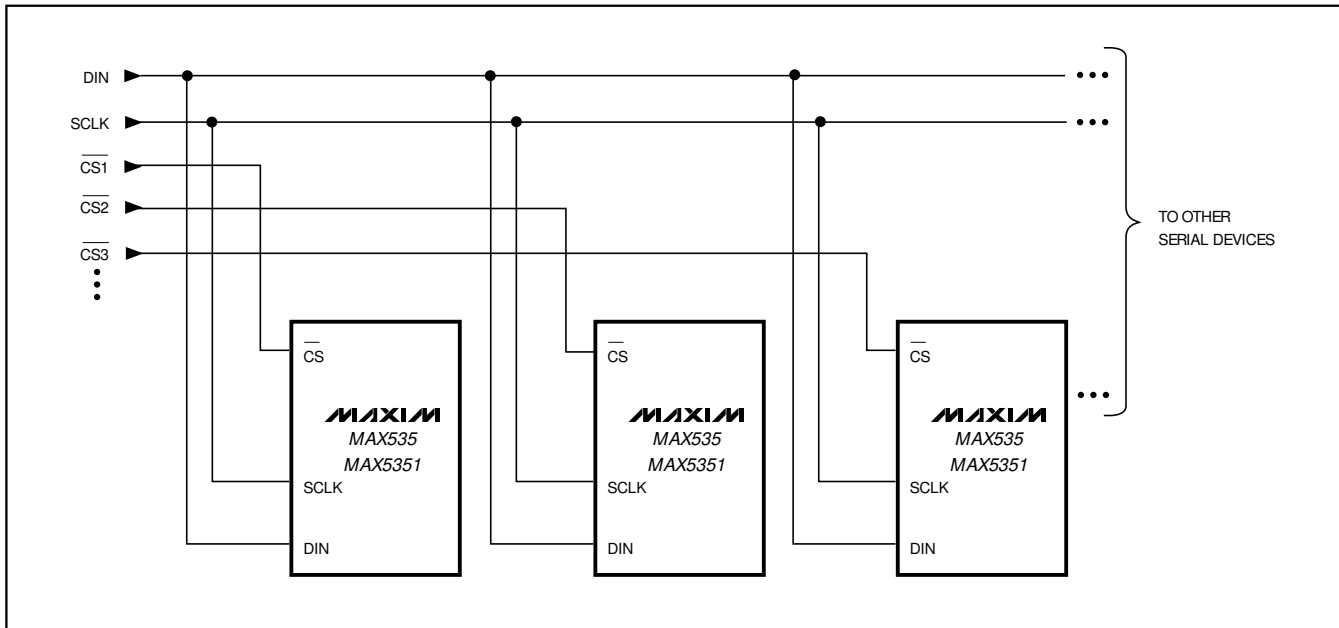

Figure 7. Multiple MAX535/MAX5351s Sharing Common DIN and SCLK Lines

Figure 7 shows a method of connecting several MAX535/MAX5351s. In this configuration, the clock and the data bus are common to all devices and separate chip-select lines are used for each IC.

Applications Information

Unipolar Output

For a unipolar output, the output voltage and the reference input have the same polarity. Figure 8 shows the MAX535/MAX5351 unipolar output circuit, which is also the typical operating circuit. Table 2 lists the unipolar output codes.

For rail-to-rail output, see Figure 9. This circuit shows the MAX535/MAX5351 with the output amplifier configured with a closed-loop gain of +2 to provide 0V to 5V full-scale range when a 2.5V reference is used. When using the MAX5351 with a 1.25V reference, this circuit provides a 0V to 2.5V full-scale range.

Bipolar Output

The MAX535/MAX5351 output can be configured for bipolar operation using Figure 10's circuit.

$$V_{OUT} = V_{REF} [(2NB / 8192) - 1]$$

where NB is the numeric value of the DAC's binary input code. Table 3 shows digital codes (offset binary) and the corresponding output voltage for Figure 10's circuit.

Table 2. Unipolar Code Table

DAC CONTENTS		ANALOG OUTPUT
MSB	LSB	
11111	1111 1111	$+V_{REF} \left(\frac{8191}{8192} \right)$
10000	0000 0001	$+V_{REF} \left(\frac{4097}{8192} \right)$
10000	0000 0000	$+V_{REF} \left(\frac{4096}{8192} \right) = \frac{+V_{REF}}{2}$
01111	1111 1111	$+V_{REF} \left(\frac{4095}{8192} \right)$
00000	0000 0001	$+V_{REF} \left(\frac{1}{8192} \right)$
00000	0000 0000	0V

Using an AC Reference

In applications where the reference has AC-signal components, the MAX535/MAX5351 have multiplying capability within the reference input range specifications. Figure 11 shows a technique for applying a sine-wave signal to the reference input where the AC signal is offset before being applied to REF. The reference voltage must never be more negative than GND.

Low-Power, 13-Bit Voltage-Output DACs with Serial Interface

Table 3. Bipolar Code Table

DAC CONTENTS			ANALOG OUTPUT
MSB	LSB		
11111	1111	1111	$+V_{REF} \left(\frac{4095}{4096} \right)$
10000	0000	0001	$+V_{REF} \left(\frac{1}{4096} \right)$
10000	0000	0000	0V
01111	1111	1111	$-V_{REF} \left(\frac{1}{4096} \right)$
00000	0000	0001	$-V_{REF} \left(\frac{4095}{4096} \right)$
00000	0000	0000	$-V_{REF} \left(\frac{4096}{4096} \right) = -V_{REF}$

The MAX535's total harmonic distortion plus noise (THD + N) is typically less than -77dB (full-scale code), and the MAX5351's THD + N is typically less than -72dB (full-scale code), given a 1Vp-p signal swing and input frequencies up to 25kHz. The typical -3dB frequency is 650kHz for both devices, as shown in the *Typical Operating Characteristics* graphs.

Digitally Programmable Current Source

The circuit of Figure 12 places an NPN transistor (2N3904 or similar) within the op-amp feedback loop to implement a digitally programmable, unidirectional current source. This circuit can be used to drive 4–20mA current loops, which are commonly used in industrial-control applications. The output current is calculated with the following equation:

$$I_{OUT} = (V_{REF} / R) \times (NB / 8192)$$

where NB is the numeric value of the DAC's binary input code and R is the sense resistor shown in Figure 12.

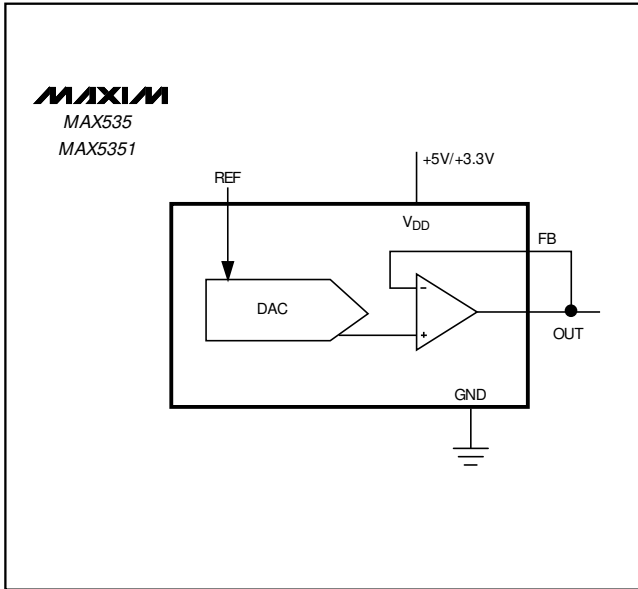

Figure 8. Unipolar Output Circuit

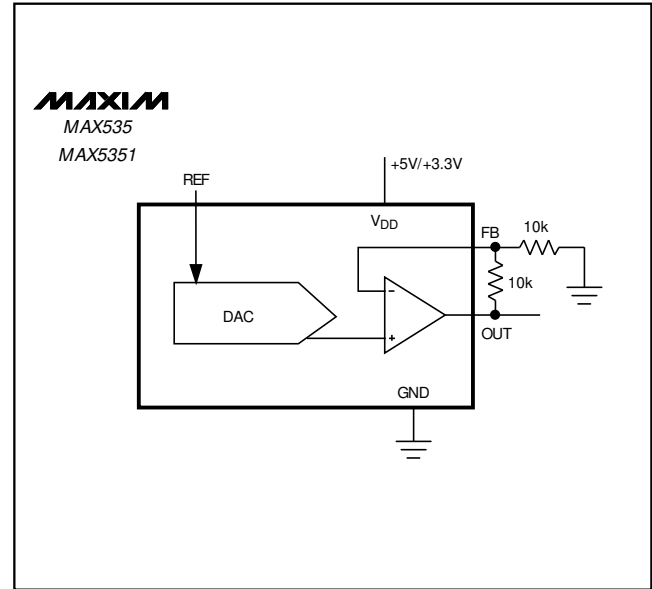

Figure 9. Unipolar Rail-to-Rail Output Circuit

Low-Power, 13-Bit Voltage-Output DACs with Serial Interface

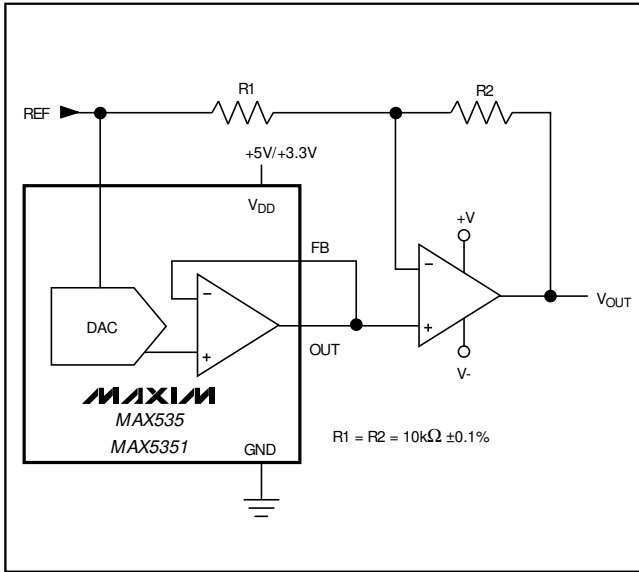

Figure 10. Bipolar Output Circuit

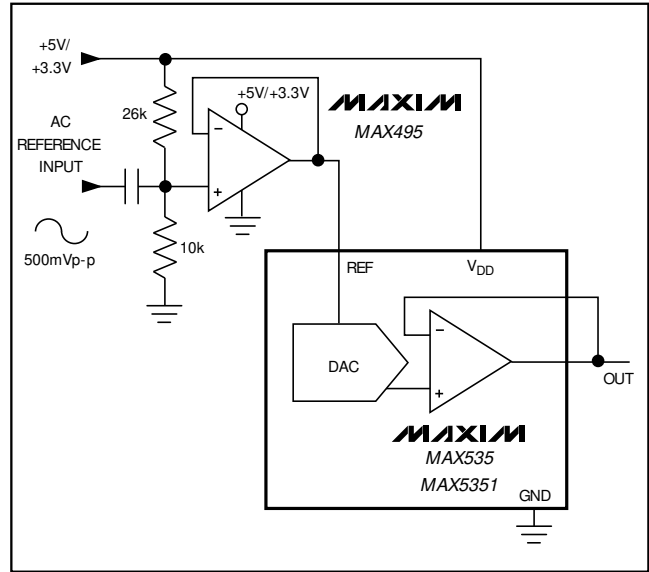

Figure 11. AC Reference Input Circuit

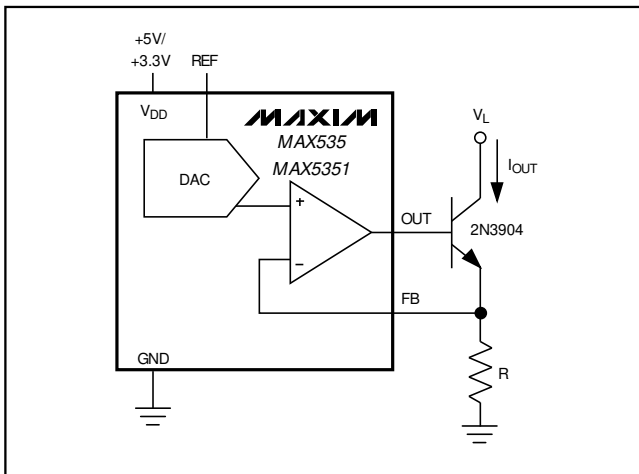

Figure 12. Digitally Programmable Current Source

Grounding and Layout Considerations

Digital or AC transient signals on GND can create noise at the analog output. Tie GND to the highest-quality ground available.

Good printed circuit board ground layout minimizes crosstalk between the DAC output, reference input, and digital input. Reduce crosstalk by keeping analog lines away from digital lines. Wire-wrapped boards are not recommended.

Power-Supply Considerations

On power-up, the input and DAC registers are cleared (set to zero code).

For rated MAX535/MAX5351 performance, REF should be at least 1.4V below V_{DD}. Bypass V_{DD} with a 4.7μF capacitor in parallel with a 0.1μF capacitor to GND. Use short lead lengths and place the bypass capacitors as close to the supply pins as possible.

Low-Power, 13-Bit Voltage-Output DACs with Serial Interface

MAX535/MAX5351

Ordering Information (continued)

PART	TEMP. RANGE	PIN-PACKAGE	INL (LSB)
MAX535AEPA	-40°C to +85°C	8 Plastic DIP	±1/2
MAX535BEPA	-40°C to +85°C	8 Plastic DIP	±1
MAX535AEUA	-40°C to +85°C	8 μMAX [†]	±1/2
MAX535BEUA	-40°C to +85°C	8 μMAX	±1
MAX535BMJA	-55°C to +125°C	8 CERDIP**	±2
MAX5351 ACPA	0°C to +70°C	8 Plastic DIP	±1
MAX5351BCPA	0°C to +70°C	8 Plastic DIP	±2
MAX5351ACUA	0°C to +70°C	8 μMAX [†]	±1
MAX5351BCUA	0°C to +70°C	8 μMAX	±2
MAX5351BC/D	0°C to +70°C	Dice*	±2
MAX5351AEPA	-40°C to +85°C	8 Plastic DIP	±1
MAX5351BEPA	-40°C to +85°C	8 Plastic DIP	±2
MAX5351AEUA	-40°C to +85°C	8 μMAX [†]	±1
MAX5351BEUA	-40°C to +85°C	8 μMAX	±2
MAX5351BMJA	-55°C to +125°C	8 CERDIP**	±4

Chip Information

TRANSISTOR COUNT: 1677

[†] Contact factory for availability.

* Dice are tested at +25°C, DC parameters only.

** Contact factory for availability and processing to MIL-STD-883.

Package Information

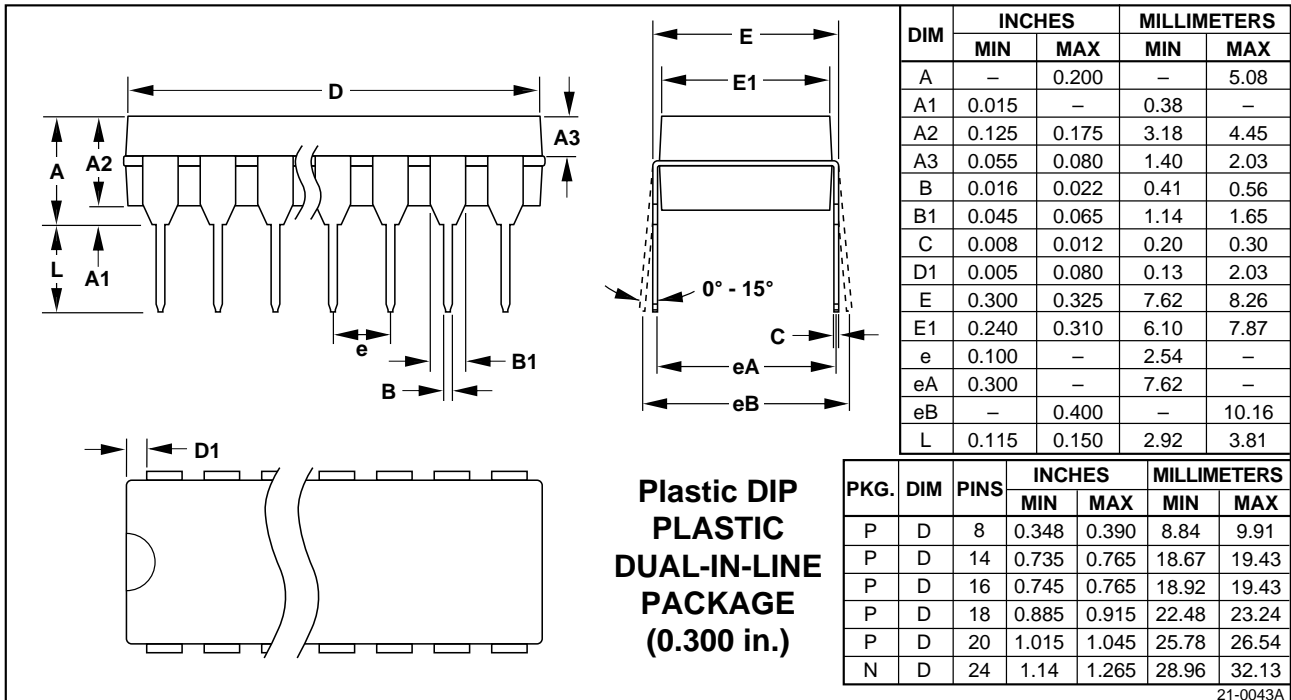

Low-Power, 13-Bit Voltage-Output DACs with Serial Interface

Package Information (continued)

DIM	INCHES		MILLIMETERS	
	MIN	MAX	MIN	MAX
A	0.036	0.044	0.91	1.11
A1	0.004	0.008	0.10	0.20
B	0.010	0.014	0.25	0.36
C	0.005	0.007	0.13	0.18
D	0.116	0.120	2.95	3.05
E	0.116	0.120	2.95	3.05
e	0.0256		0.65	
H	0.188	0.198	4.78	5.03
L	0.016	0.026	0.41	0.66
α	0°	6°	0°	6°

21-0036D

**8-PIN μMAX
MICROMAX SMALL-OUTLINE
PACKAGE**

DIM	INCHES		MILLIMETERS	
	MIN	MAX	MIN	MAX
A	—	0.200	—	5.08
B	0.014	0.023	0.36	0.58
B1	0.038	0.065	0.97	1.65
C	0.008	0.015	0.20	0.38
E	0.220	0.310	5.59	7.87
E1	0.290	0.320	7.37	8.13
e	0.100		2.54	
L	0.125	0.200	3.18	5.08
L1	0.150	—	3.81	—
Q	0.015	0.070	0.38	1.78
S	—	0.098	—	2.49
S1	0.005	—	0.13	—

DIM	PINS	INCHES		MILLIMETERS	
		MIN	MAX	MIN	MAX
D	8	—	0.405	—	10.29
D	14	—	0.785	—	19.94
D	16	—	0.840	—	21.34
D	18	—	0.960	—	24.38
D	20	—	1.060	—	26.92
D	24	—	1.280	—	32.51

21-0045A

**CERDIP
CERAMIC DUAL-IN-LINE
PACKAGE
(0.300 in.)**

Maxim cannot assume responsibility for use of any circuitry other than circuitry entirely embodied in a Maxim product. No circuit patent licenses are implied. Maxim reserves the right to change the circuitry and specifications without notice at any time.

16 Maxim Integrated Products, 120 San Gabriel Drive, Sunnyvale, CA 94086 (408) 737-7600