

MAX7391

Speed-Switching Clock Generator with Power Fail

General Description

The MAX7391 replaces ceramic resonators, crystals, and supervisory functions for microcontrollers in 3.3V and 5V applications.

The MAX7391 provides a clock source, reset, and power-fail functions. The programmable power-fail function provides early warning of power failure and is configurable to detect either an external voltage or the V_{CC} supply to the device.

The clock output can be switched between normal and half-speed operation. This functionality allows the microcontroller to operate at reduced power and may be used to extend the time available to perform housekeeping tasks, such as writing data to flash during a power failure. Connecting the power-fail output to the SPEED input reduces clock speed automatically during power-fail events.

The MAX7391 clock output is factory programmed to a frequency in the 1MHz to 16MHz range. Four standard frequencies are available. Other frequencies are available upon request. The maximum operating supply current is 5.5mA (typ) with a clock frequency of 12MHz.

Unlike typical crystal and ceramic resonator oscillator circuits, the MAX7391 is resistant to EMI and vibration, and operates reliably at high temperatures. The high-output drive current and absence of high-impedance nodes make the oscillator invulnerable to dirty or humid operating conditions.

The MAX7391 is available in an 8-pin μ MAX[®] package. The MAX7391 standard operating temperature range is from -40°C to +125°C.

Applications

- White Goods
- Appliances and Controls
- Handheld Products
- Portable Equipment
- Microcontroller Systems

Typical Application Circuit, Functional Diagram, and Selector Guide appear at end of data sheet.

μ MAX is a registered trademark of Maxim Integrated Products, Inc.

Benefits and Features

- Robust Microcontroller Clock and Supervisory Functions in a Single Package
- Integrated Reset and Power-Fail Functions
- Speed Select
- +2.7V to +5.5V Operation
- Factory-Trimmed Oscillator
- Reset Valid Down to 1.1V Supply Voltage
- ± 10 mA Clock-Output Drive Current
- $\pm 4\%$ Total Accuracy for -40°C to +125°C
- $\pm 2.75\%$ Total Accuracy for 0°C to +85°C
- 5.5mA Operating Current (12MHz Version)
- -40°C to +125°C Temperature Range
- Surface-Mount Package
- 1MHz to 16MHz Factory Preset Frequency Range

Ordering Information

PART	TEMP RANGE	PIN-PACKAGE
MAX7391srff	-40°C to +125°C	8 μ MAX

Note: "s" is a placeholder for the reset output type. Insert the symbol found in Table 2 in the place of "s." "r" is a placeholder for the power-on reset (POR) voltage. Insert the symbol found in Table 1 in the place of "r." "ff" is a placeholder for the nominal output frequency. Insert the symbol found in Table 3 in the place of "ff." For example, MAX7391CMTP describes a device with 4.38V reset level, open-collector RST output, and a clock output frequency of 8MHz.

Pin Configuration

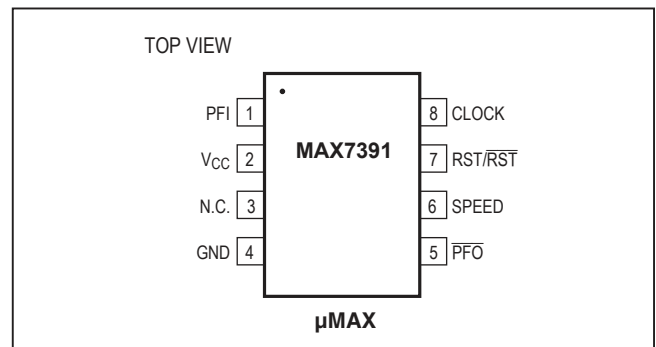

Absolute Maximum Ratings

V _{CC} to GND.....	-0.3V to +6.0V	Operating Temperature Range	-40°C to +125°C
All Other Pins to GND	-0.3V to (V _{CC} + 0.3V)	Junction Temperature.....	+150°C
CLOCK, RST/ $\overline{\text{RST}}$, $\overline{\text{PFO}}$ Output Current	$\pm 50\text{mA}$	Storage Temperature Range	-65°C to +150°C
Continuous Power Dissipation		Lead Temperature (soldering, 10s)	+300°C
8-Pin μMAX (derate 4.5mW/°C over T _A = +70°C).....	362mW		

Stresses beyond those listed under "Absolute Maximum Ratings" may cause permanent damage to the device. These are stress ratings only, and functional operation of the device at these or any other conditions beyond those indicated in the operational sections of the specifications is not implied. Exposure to absolute maximum rating conditions for extended periods may affect device reliability.

Electrical Characteristics

(Typical Application Circuit, V_{CC} = +2.7V to +5.5V, T_A = -40°C to +125°C, 1MHz to 16MHz output frequency range, typical values at V_{CC} = +5.0V, T_A = +25°C, unless otherwise noted.) (Note 1)

PARAMETER	SYMBOL	CONDITIONS	MIN	TYP	MAX	UNITS
POWER REQUIREMENTS						
Operating Supply Voltage	V _{CC}		2.7		5.5	V
Valid RST/ $\overline{\text{RST}}$ Supply Voltage	V _{CCR}	Minimum supply voltage for valid RST/ $\overline{\text{RST}}$ output, T _A = 0°C to +85°C			1.1	V
Operating Supply Current	I _{CC}	f _{CLOCK} = 12MHz			5.5	mA
		f _{CLOCK} = 8MHz			4.5	
LOGIC INPUT: SPEED						
Input Leakage Current	I _{LEAK}	Input is high			0.5	μA
Logic-Input High Voltage	V _{IH}		0.7 x V _{CC}			V
Logic-Input Low Voltage	V _{IL}				0.3 x V _{CC}	V
PUSH-PULL LOGIC OUTPUTS: RST/$\overline{\text{RST}}$						
Output High	V _{OH}	I _{SOURCE} = 1mA	V _{CC} - 1.5			V
Output Low	V _{OL}	I _{SINK} = 3mA		0.05	0.4	V
OPEN-DRAIN LOGIC OUTPUTS: $\overline{\text{RST}}$, $\overline{\text{PFO}}$						
Output Low	V _{OLO}	I _{SINK} = 3mA		0.05	0.4	V
OUTPUT: CLOCK						
CLOCK Output High Voltage	V _{OHC}	I _{SOURCE} = 5mA	V _{CC} - 0.3			V
CLOCK Output Low Voltage	V _{OLC}	I _{SINK} = 5mA			0.3	V
CLOCK Accuracy	f _{CLOCK}	Table 3, V _{CC} = +5.0V	-4		+4	%

Electrical Characteristics (continued)

(Typical Application Circuit, $V_{CC} = +2.7V$ to $+5.5V$, $T_A = -40^\circ C$ to $+125^\circ C$, 1MHz to 16MHz output frequency range, typical values at $V_{CC} = +5.0V$, $T_A = +25^\circ C$, unless otherwise noted.) (Note 1)

PARAMETER	SYMBOL	CONDITIONS	MIN	TYP	MAX	UNITS
Clock Frequency Temperature Coefficient		$V_{CC} = +5.0V$ (Note 2)		140	400	ppm/ $^\circ C$
Clock Frequency Supply Voltage Coefficient		$T_A = +25^\circ C$ (Note 2)		0.67	1	%/V
CLOCK Duty Cycle		(Note 2)	45	50	55	%
CLOCK Output Jitter		Observation for 20s using a 500MHz oscilloscope		310		ps RMS
Output Rise Time	t_R	$C_{LOAD} = 10pF$, 10% to 90% of full scale (Note 2)		2.5	7.0	ns
Output Fall Time	t_F	$C_{LOAD} = 10pF$, 90% to 10% of full scale (Note 2)		2.5	7.5	ns
INTERNAL POWER-ON RESET						
Reset Voltage	V_{TH+}	V_{CC} rising, Table 1	$T_A = +25^\circ C$	V_{TH} - 1.5%	V_{TH} + 1.5%	V
			$T_A = -40^\circ C$ to $+125^\circ C$	V_{TH} - 2.5%	V_{TH} + 2.5%	
	V_{TH-}	V_{CC} falling		0.98 x V_{TH+}		
Reset Timeout Period	t_{RST}	Figure 1	86	135	250	μs
POWER FAIL						
Power-Fail Select Threshold	V_{SEL}	PFI input	0.65 x V_{CC}		0.85 x V_{CC}	V
V_{CC} Monitoring Threshold (Internal Threshold)	V_{ITH}	V_{CC} rising	4.06	4.38	4.60	V
Internal Threshold Hysteresis	V_{IHYST}	V_{CC} falling	1.0	2	4.0	% V_{ITH}
PFI Monitoring Threshold (External Threshold)	V_{ETH}	PFI rising	0.9	1.1	1.4	V
External Threshold Hysteresis	V_{EHYST}	PFI falling	1.0	3.5	8.0	% V_{ETH}

Note 1: All parameters are tested at $T_A = +25^\circ C$. Specifications over temperature are guaranteed by design.

Note 2: Guaranteed by design. Not production tested.

Typical Operating Characteristics

(Typical Application Circuit, $V_{CC} = +5V$, $f_{CLOCK} = 16MHz$, $T_A = +25^{\circ}C$, unless otherwise noted.)

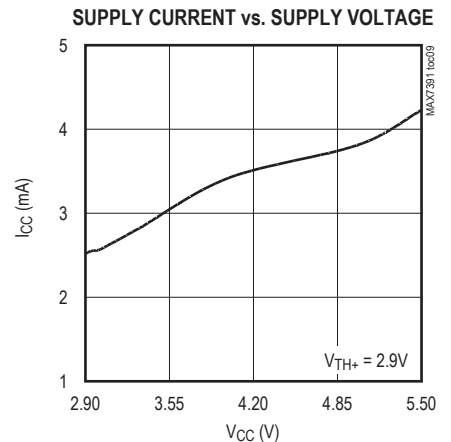
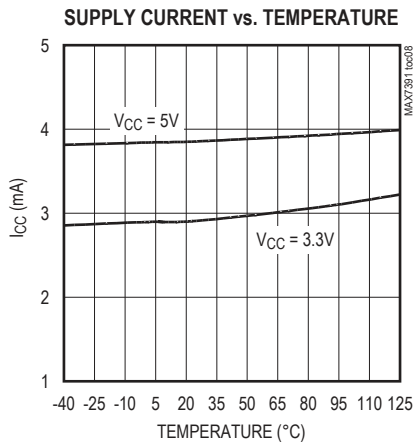
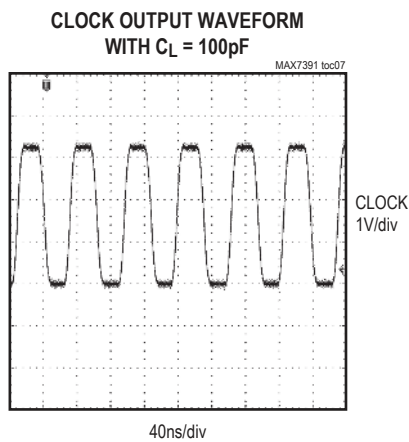
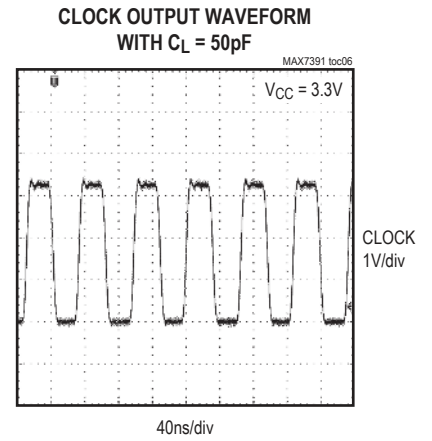
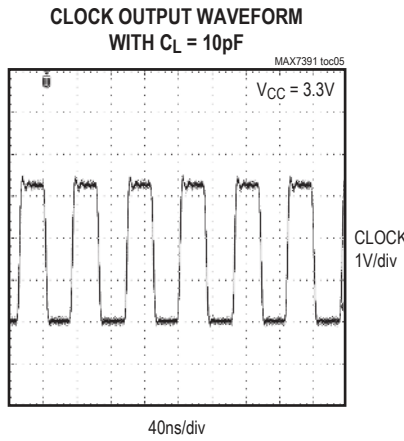
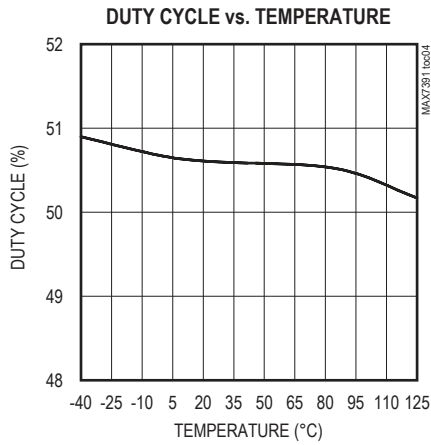
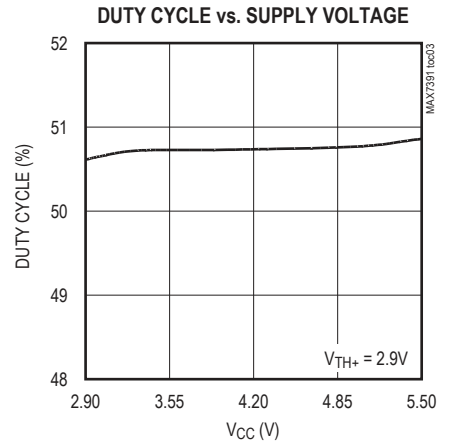
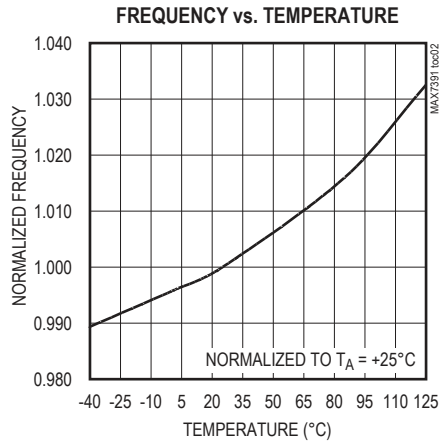
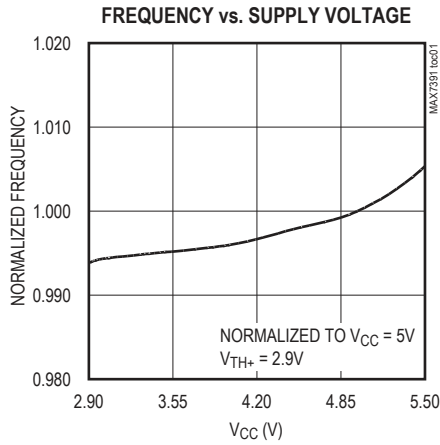

Typical Operating Characteristics (continued)

(Typical Application Circuit, $V_{CC} = +5V$, $f_{CLOCK} = 16MHz$, $T_A = +25^{\circ}C$, unless otherwise noted.)

CLOCK SETTLING TIME FROM START

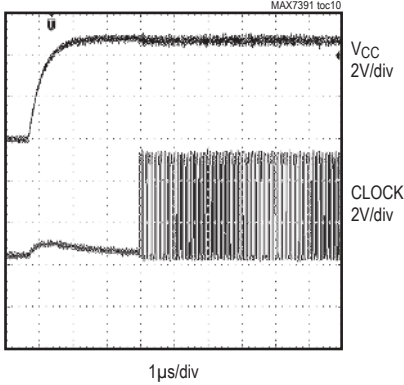

POWER-ON RESET BEHAVIOR

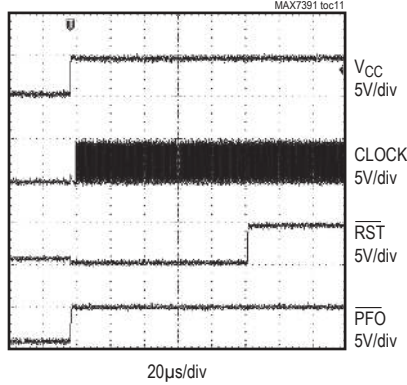

MAXIMUM V_{CC} TRANSIENT DURATION vs. RESET THRESHOLD OVERDRIVE

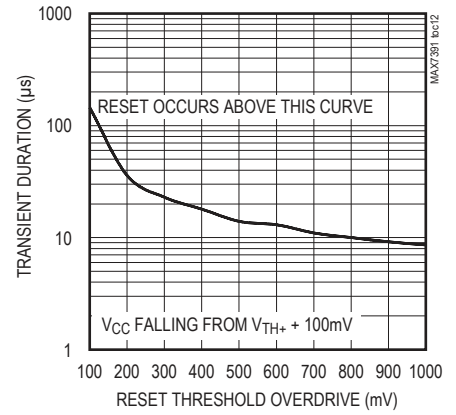

CLOCK RESPONSE TO SPEED SELECT INPUT

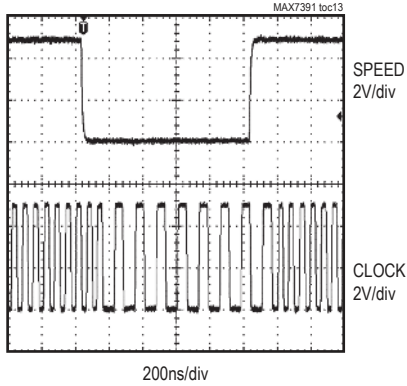

RISING THRESHOLD vs. TEMPERATURE

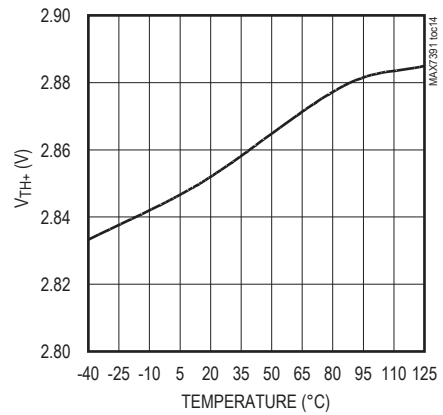

Pin Description

PIN	NAME	FUNCTION
1	PFI	Power-Fail Input. PFI monitors the condition of either an external supplied voltage or V_{CC} . See the Power Fail section for more details.
2	V_{CC}	Power Input. Connect V_{CC} to the power supply. Bypass V_{CC} to GND with a 0.1 μ F capacitor. Install the bypass capacitor as close to the device as possible.
3	N.C.	No Connection
4	GND	Ground
5	\overline{PFO}	Power-Fail Output. Open-drain output asserts when the voltage being monitored drops below the power-fail threshold voltage.
6	SPEED	Clock-Speed Select Input. Connect SPEED high for the factory-trimmed clock output frequency. Connect SPEED low to reduce the clock output frequency by half.
7	RST/ \overline{RST}	Reset Output. Reset output is available in one of three configurations: push-pull RST, push-pull \overline{RST} , or open-drain \overline{RST} . The reset output occurs if any combination of the following conditions occurs: reset output is asserted during power-up, and whenever V_{CC} is below the reset threshold level; for devices with WDI, reset output asserts when WDI does not receive a rising or falling edge within the watchdog timeout period.
8	CLOCK	Clock Output

Detailed Description

The MAX7391 replaces ceramic resonators, crystals, and supervisory functions for microcontrollers in 3.3V and 5V applications.

The MAX7391 provides a clock source, reset, and power-fail functions. The power-fail output provides early warning of power failure. The power-fail threshold is configurable to detect either an external voltage or the V_{CC} supply voltage to the device.

The clock output can be switched between normal and half-speed operation. This functionality allows the microcontroller to operate at reduced power and may be used to extend the time available to perform housekeeping tasks, such as writing data to flash, during a power failure. Connecting the power-fail output (\overline{PFO}) to the SPEED input reduces clock speed automatically during power-fail events.

The integrated reset provides the power-supply monitoring functions necessary to ensure correct microcontroller operation. The reset circuit has built-in power-supply transient immunity and provides both power-on reset and power-fail or brownout reset functionality. Two standard factory-trimmed reset levels are available.

A power-fail function is provided for power-supply voltage monitoring and can provide advance notice of an impending power failure. The power-fail input monitors external power-supply voltages through an external resistive divider. Connect PFI to V_{CC} to monitor V_{CC} .

Clock Output (CLOCK)

The push-pull clock output (CLOCK) drives a ground-connected 1k Ω load or a positive supply connected 500 Ω load to within 300mV of either supply rail. CLOCK remains stable over the full operating voltage range and does not generate short output cycles during either power-on or power-off. A typical startup characteristic is shown in the *Typical Operating Characteristics* section.

The clock output frequency is reduced by a factor of two by taking SPEED low. This functionality allows the microcontroller to operate at reduced power and may be used to extend the time available to perform housekeeping tasks, such as writing data to flash during power failure.

Reset

The reset function drives the microcontroller reset input to prevent operation in the cases of the initial power-on setting, low power-supply voltages, and the failed watchdog operations. Three reset output versions are available: push-pull RST, push-pull \overline{RST} , and open-drain \overline{RST} . The reset timeout period (t_{RST}) is nominally 135s.

Power-On Reset (POR)

The internal power-on reset (POR) circuit detects the power-supply voltage (V_{CC}) level at startup. The POR circuit starts the oscillator when V_{CC} exceeds the reset rising threshold level (V_{TH+}). The reset output remains asserted from the time V_{CC} crosses the V_{TH+} and continues to be asserted for the reset timeout period (t_{RST}). Upon completion of the reset timeout, the reset output is released. See Figure 1.

Low-Voltage Lockout

The reset output asserts whenever V_{CC} drops below the reset falling threshold, V_{TH-} . The difference between the reset rising and falling threshold values is $V_{TH+} - (V_{TH-})$. The nominal hysteresis value is 2% of the reset rising threshold value. The reset detection circuitry provides filtering to prevent triggering on negative voltage spikes. See the Typical Operating Characteristics for a plot of maximum transient duration without causing a reset pulse vs. reset comparator overdrive.

Figure 1 shows the reset output (RST/\overline{RST}) behavior during power-up and brownout.

Power Fail

The power-fail function provides early warning of a power failure. The power-fail comparator detects the condition of either an external voltage or the V_{CC} supply voltage.

Internal (V_{CC}) detection is configured by connecting PFI to V_{CC} . The internal V_{CC} rising threshold (V_{ITH}) is set at 4.38V. The open-drain \overline{PFO} asserts low if the V_{CC}

supply voltage drops below the V_{CC} falling threshold value (V_{IHYST}). The V_{CC} falling threshold is nominally 2% below the V_{CC} rising threshold.

External power-fail detection is selected when the applied voltage on PFI (V_{PFI}) is less than $0.65 \times V_{CC}$ (V_{SEL} minimum). When the voltage on PFI is more than $0.85 \times V_{CC}$ (V_{SEL} maximum), the device switches to internal monitoring. External power-fail detection is normally used with a resistive divider from the supply being monitored. See the *Typical Application Circuit*. For a 3.3V supply, the voltage on PFI needs to be set externally and less than $0.65 \times V_{CC}$ (V_{SEL} minimum). To set the voltage on PFI externally, choose R1 and R2 so that:

$$V_{PFI} = \frac{R2 \times \text{POWERSUPPLY}}{R2 + R1}$$

See Figure 1 for \overline{PFO} behavior during power-up and brownout.

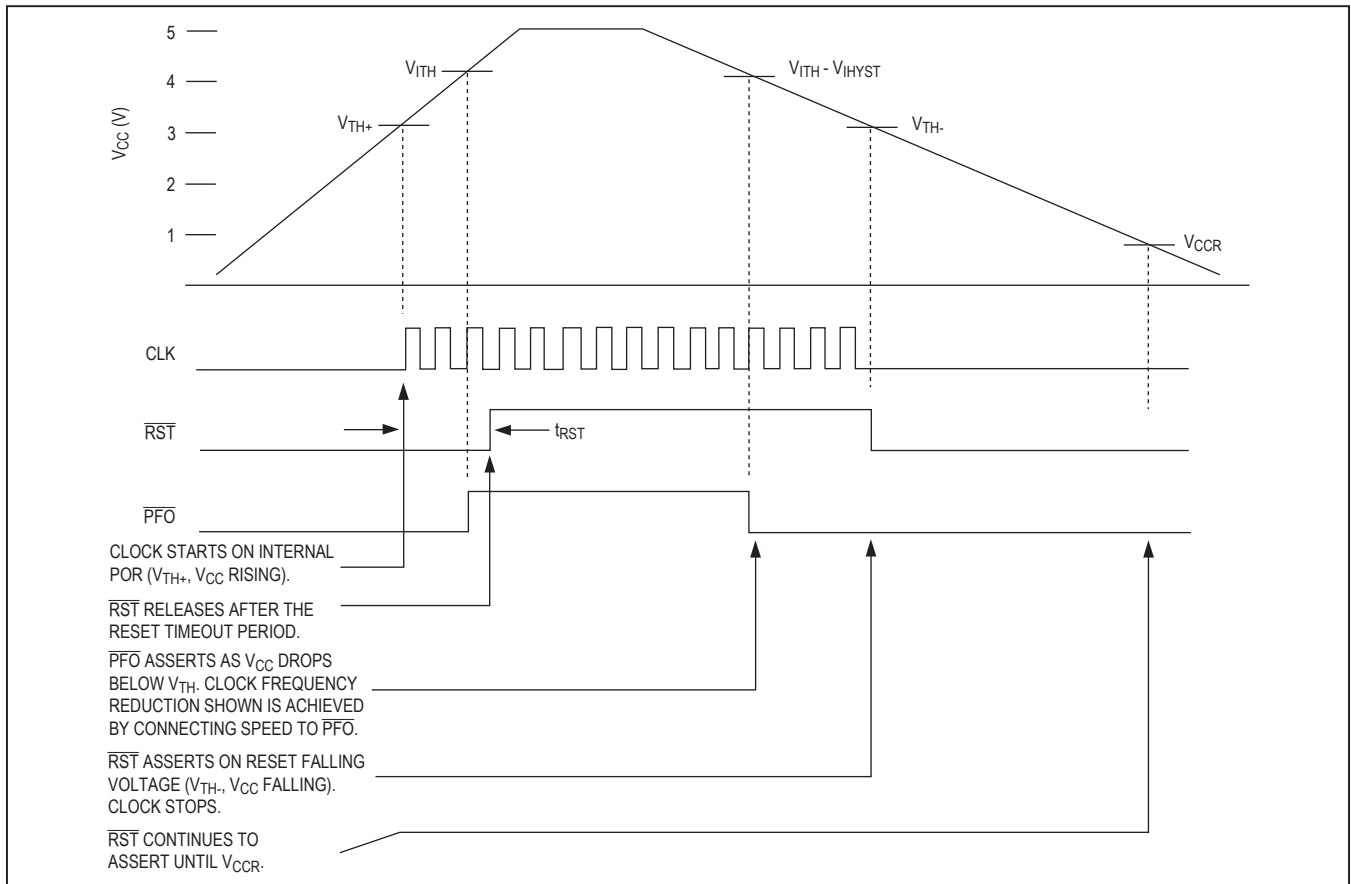

Figure 1. RST/\overline{RST} and \overline{PFO} Behavior During Power-Up and Brownout

Selector Guide

PART	FREQUENCY RANGE (MHz)	RESET FUNCTION	WATCHDOG INPUT (WDI) / WATCHDOG OUTPUT (WDO)	POWER-FAIL INPUT (PFI)/POWER-FAIL OUTPUT (PFO)	SPEED	PIN- PACKAGE
MAX7387	1 to 32	Yes	Yes/yes	Yes/yes	—	10 μ MAX
MAX7388	1 to 32	Yes	Yes/no	No/yes	—	8 μ MAX
MAX7389	1 to 32	Yes	Yes/yes	—	—	8 μ MAX
MAX7390	1 to 32	Yes	Yes/no	—	Yes	8 μ MAX
MAX7391	1 to 32	Yes	—	Yes/yes	Yes	8 μ MAX

Note: Other versions with different features are available. Refer to the MAX7387/MAX7388 and MAX7389/MAX7390 data sheets.

Applications Information

Interfacing to a Microcontroller Clock Input

The clock output is a push-pull, CMOS logic output, which directly drives any microprocessor (μ P) or microcontroller (μ C) clock input. There are no impedancematching issues when using the MAX7391. Operate the MAX7391 and μ C (or other clock input device) from the same supply voltage level. Refer to the microcontroller data sheet for clock-input compatibility with external clock signals. Table 3 lists clock output frequency.

The MAX7391 requires no biasing components or load capacitance. When using the MAX7391 to retrofit a crystal oscillator, remove all biasing components from the oscillator input.

Table 1. POR Voltage

POWER-ON RESET VOLTAGE (V_{TH})	r
4.38	M
3.96	J
3.44	N
3.34	P
3.13	Q
2.89	S
2.82	V
2.5	X

Note: Standard values are shown in bold. Contact factory for other POR voltages.

Table 2. Reset Output Type

OUTPUT TYPE	s
Push-pull RST	A
Push-pull $\overline{\text{RST}}$	B
Open collector $\overline{\text{RST}}$	C

Note: Standard values are shown in bold. Contact factory for other POR voltages.

Power-Supply Considerations

The MAX7391 operates with power-supply voltages in the 2.7V to 5.5V range. Good power-supply decoupling is needed to maintain the power-supply rejection performance of the MAX7391. Bypass V_{CC} to GND with a 0.1 μ F surface-mount ceramic capacitor. Mount the bypass capacitor as close to the device as possible. If possible, mount the MAX7391 close to the microcontroller's decoupling capacitor so that additional decoupling is not required.

A larger-value bypass capacitor is recommended if the MAX7391 is to operate with a large capacitive load. Use a bypass capacitor value of at least 1000 times that of the output load capacitance.

Output Jitter

The MAX7391's jitter performance is given in the *Electrical Characteristics* table as a peak-to-peak value obtained by observing the output of the device for 20s with a 500MHz oscilloscope. Jitter measurements are approximately proportional to the period of the output frequency of the device. Thus, a 4MHz part has approximately twice the jitter value of an 8MHz part.

The jitter performance of all clock sources degrades in the presence of mechanical and electrical interference. The MAX7391 is immune to vibration, shock, and EMI influences, and thus provides a considerably more robust clock source than crystal- or ceramic-resonatorbased oscillator circuits.

Table 3. Clock Output Frequency

CLOCK FREQUENCY (f_{CLOCK}) (MHz)	ff
4	RD
8	TP
12	VB
16	WB

Note: Contact factory for other frequencies.

Functional Diagram

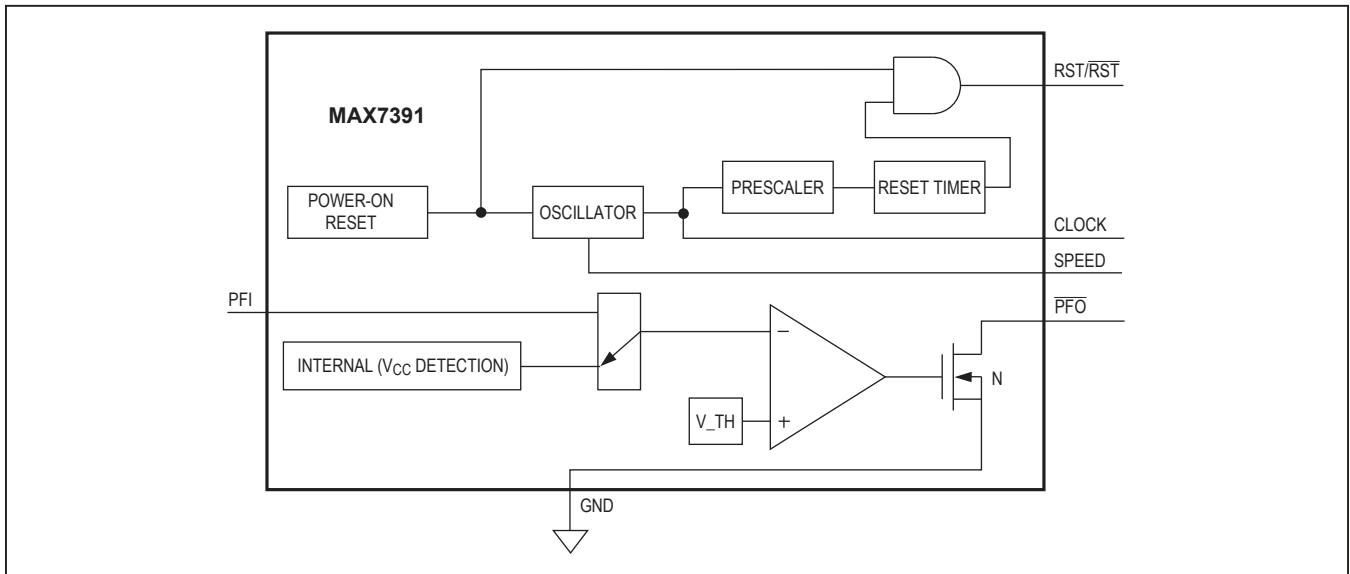

Typical Application Circuit

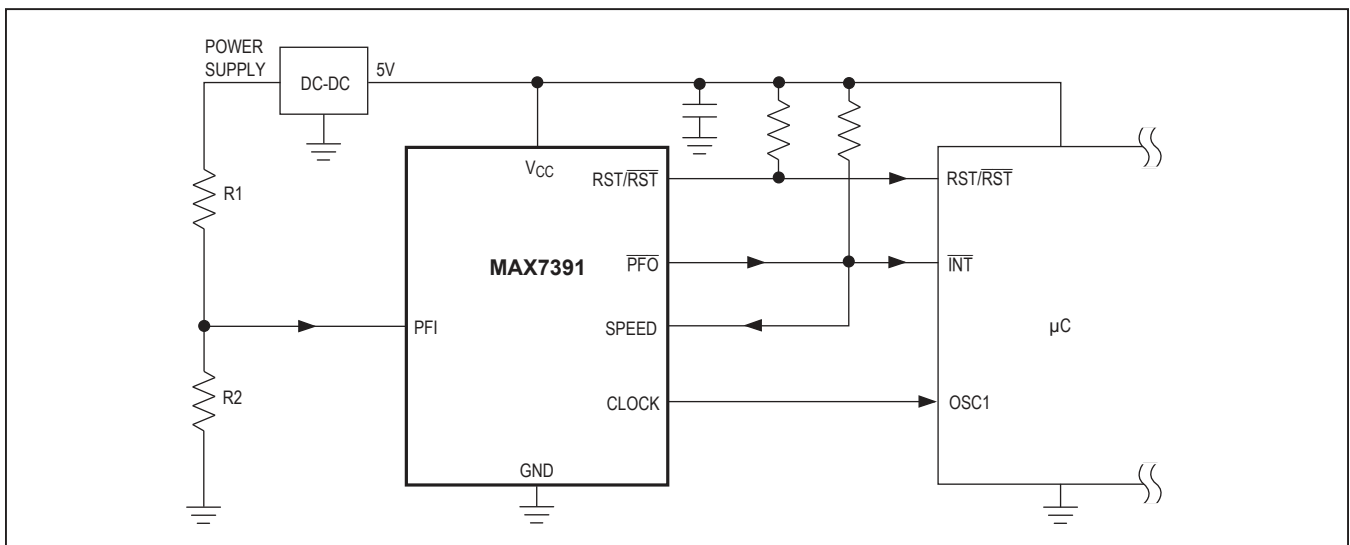

Chip Information

PROCESS: BiCMOS

Package Information

For the latest package outline information and land patterns (footprints), go to www.maximintegrated.com/packages. Note that a "+", "#", or "-" in the package code indicates RoHS status only. Package drawings may show a different suffix character, but the drawing pertains to the package regardless of RoHS status.

PACKAGE TYPE	PACKAGE CODE	OUTLINE NO.	LAND PATTERN NO.
8 µMAX	U8-1	21-0036	90-0092

Revision History

REVISION NUMBER	REVISION DATE	DESCRIPTION	PAGES CHANGED
0	1/06	Initial release	—
1	4/14	No IV OPNs; removed Automotive reference from <i>Applications</i> section	1

For pricing, delivery, and ordering information, please contact Maxim Direct at 1-888-629-4642, or visit Maxim Integrated's website at www.maximintegrated.com.

Maxim Integrated cannot assume responsibility for use of any circuitry other than circuitry entirely embodied in a Maxim Integrated product. No circuit patent licenses are implied. Maxim Integrated reserves the right to change the circuitry and specifications without notice at any time. The parametric values (min and max limits) shown in the Electrical Characteristics table are guaranteed. Other parametric values quoted in this data sheet are provided for guidance.