

THIS DRAWING IS UNPUBLISHED. RELEASED FOR PUBLICATION ,19 .
 © COPYRIGHT 19 BY AMP INCORPORATED. ALL RIGHTS RESERVED.

LOC	DIST	REVISIONS					
		P	LTR	DESCRIPTION	DATE	DWN	APVD
G	14		0	PR 97-120	18NOV97	LO	BB

- 1. STAMP AMP 12-10* APPROX AS SHOWN
- 2. WIRE INSUL DIA, 3.81-6.35 [.150-.250]
- 3. TONGUE MATL THK, 1.02±0.05 [.040±.002]
- 4. AMP TESTED AND CONFORMS TO UL486A BUT NOT SUBMITTED TO UL™ FOR APPROVAL

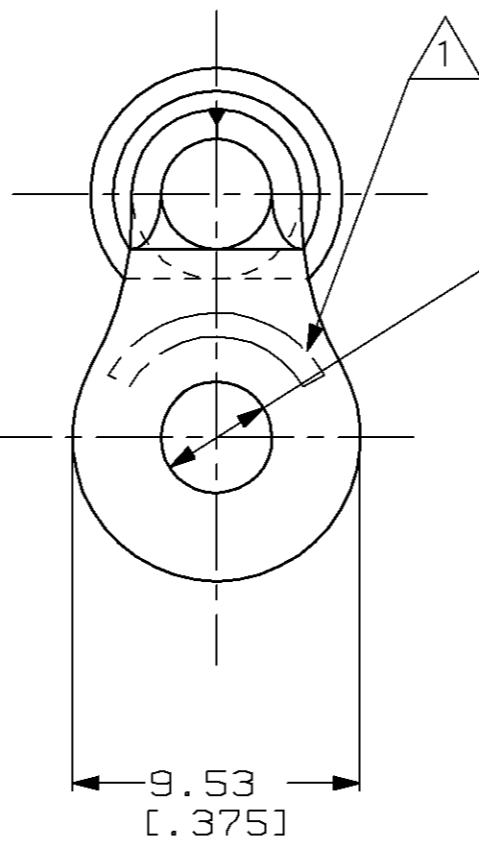
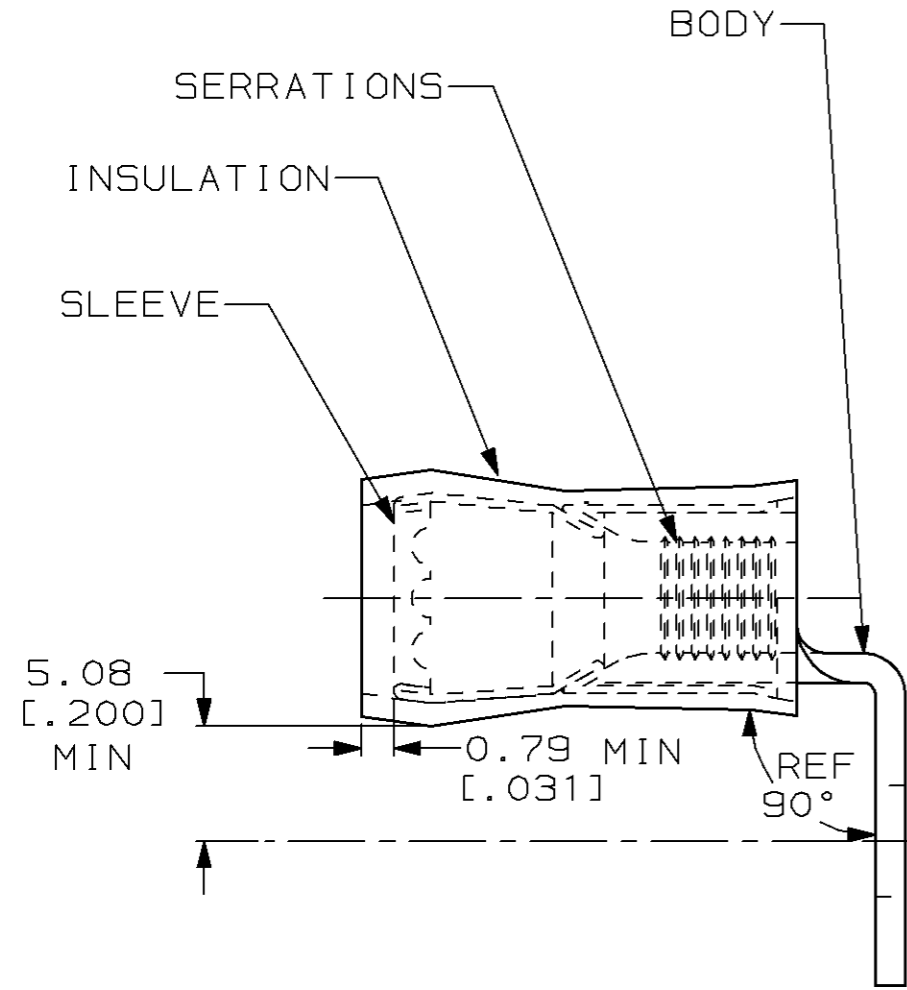

-	-	-
500	LOOSE PIECE	696020-1
QTY	PACKAGE TYPE	PART NO

**AMP INCORPORATED
CUSTOMER SERVICE SYSTEM**

FOR ADDITIONAL PRODUCT INFORMATION OR COPIES OF DRAWINGS AND TECHNICAL DOCUMENTS: PRODUCT INFORMATION CENTER 1-800-522-6752

FOR APPLICATION TOOLING INFORMATION: TOOLING ASSISTANCE CENTER 1-800-722-1111

FOR ORDER ENTRY: 1-800-526-5142

MAX RECOMMENDED OPERATING TEMPERATURE:
105°C [221°F]

VOLTAGE RATING:
300 VOLT MAX

CIRCULAR MIL AREA:
2.62mm² - 6.64mm²
[5,180-13,100]

THIS DRAWING IS A CONTROLLED DOCUMENT FOR AMP INCORPORATED. IT IS SUBJECT TO CHANGE AND THE CONTROLLING ENGINEERING ORGANIZATION SHOULD BE CONTACTED FOR THE LATEST REVISION.

DIMENSIONS: mm [in]

TOLERANCES UNLESS OTHERWISE SPECIFIED:

0 PLC	±-
1 PLC	±-
2 PLC	±0.20 [.008]
3 PLC	±-
4 PLC	±-
ANGLES	±-

MATERIAL: BODY & SLEEVE, CU PER ASTM B-152; INSUL, NYLON, COLOR, YELLOW

FINISH: BODY & SLEEVE, TIN PLATE PER ASTM B-545

DWN	L OLMEDA	18NOV97	AMP AMP Incorporated Harrisburg, PA 17105-3608
CHK	M ELLIS	18NOV97	
APVD	T MICHIELUTTI	18NOV97	
PRODUCT SPEC	NAME		
APPLICATION SPEC	TERMINAL, RING TONGUE, PIDG™, WIRE SIZE, 12-10, 90°		DRAWING NO C-696020
WEIGHT	SIZE	CAGE CODE	
CUSTOMER DRAWING			SCALE 6:1 SHEET 1 OF 1 REV 0