

POE+ SHOWN

ASSEMBLY PART NUMBER	DIM A	
172812-3000	2.60	POE+
172812-3600	3.43	
172812-3500	3.56	
173308-3600	2.60	4P POE
173308-3000	3.43	
173308-3500	3.56	

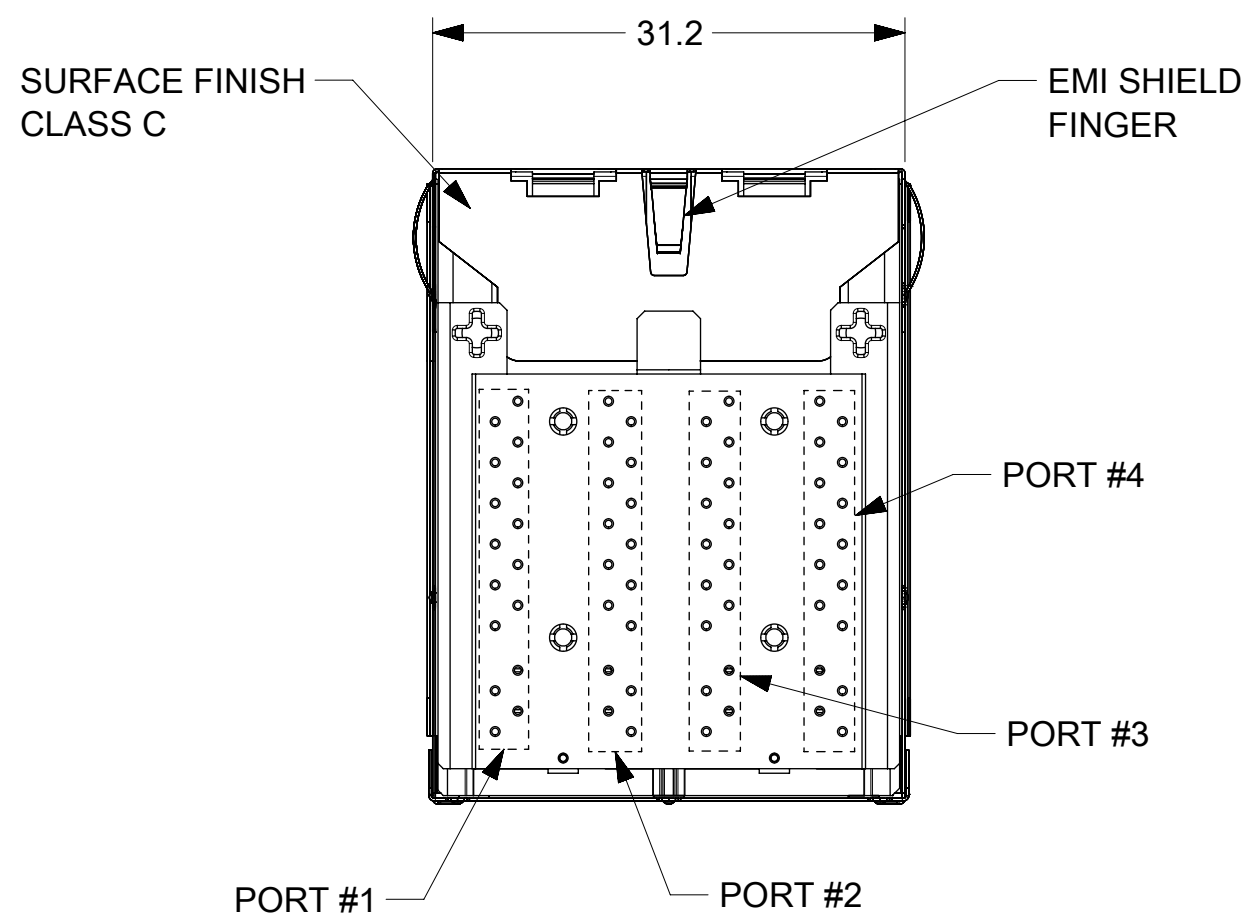
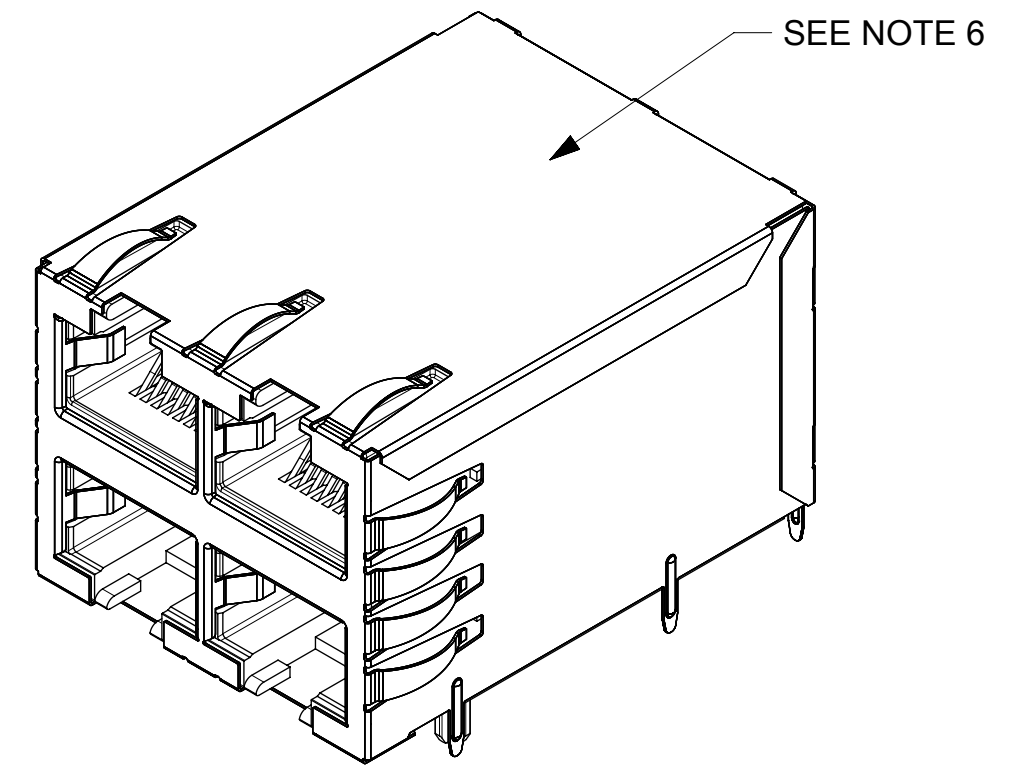
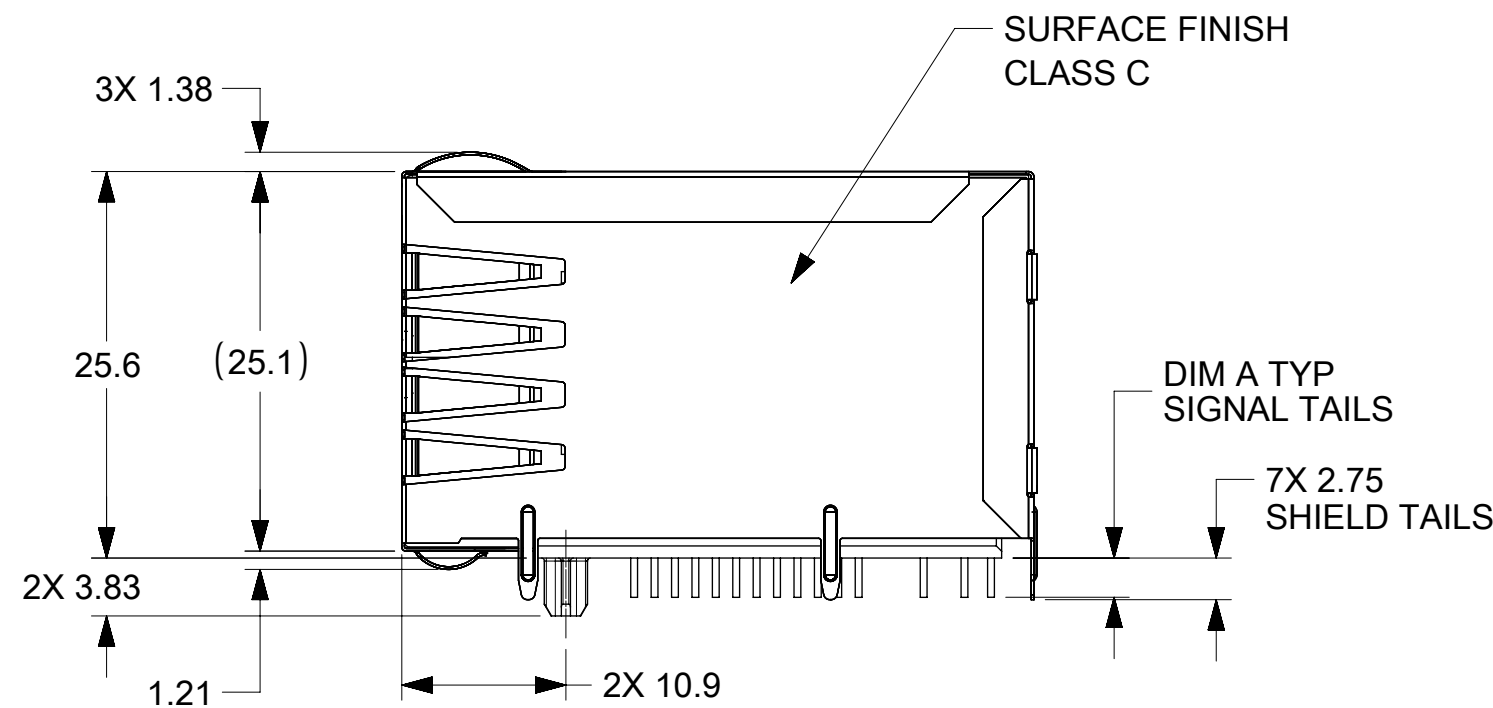
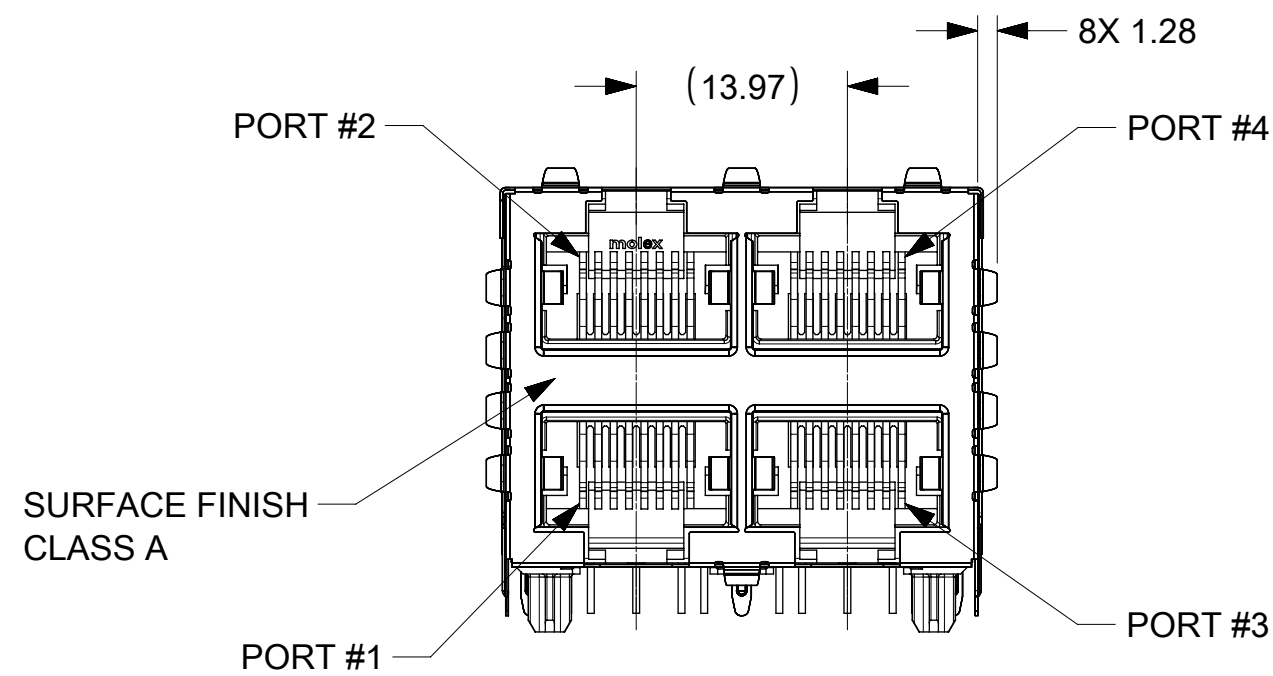
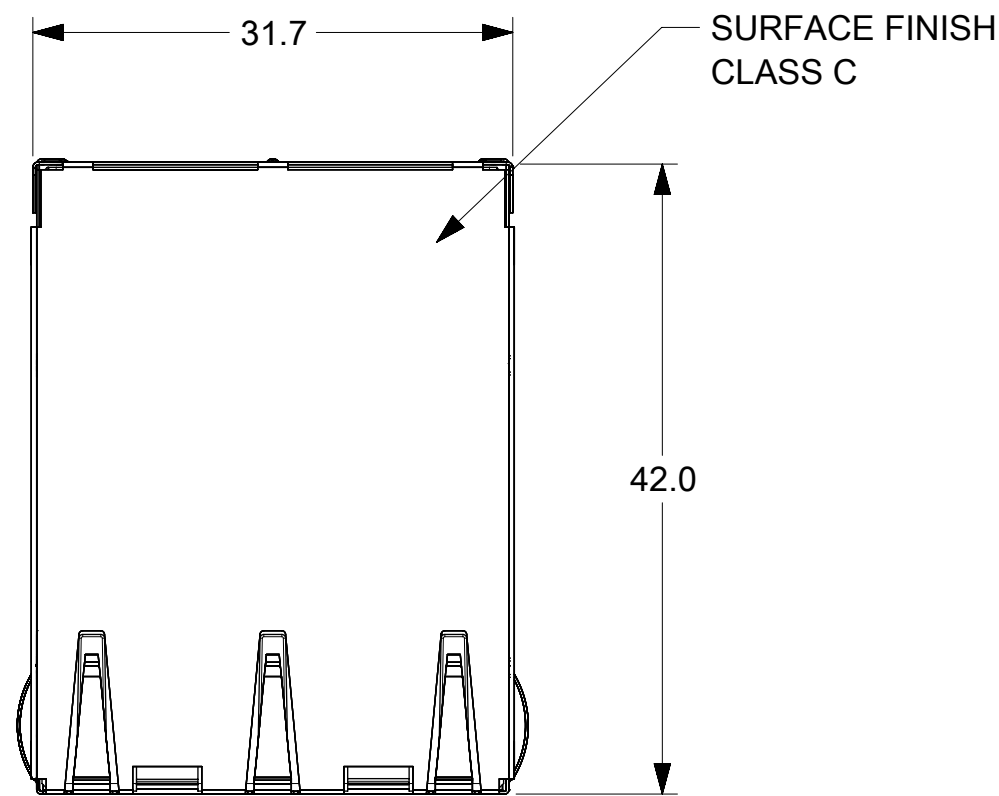

NOTES:

- MATERIAL:**
HOUSING: POLYESTER, GLASS FILLED, UL94V-0, COLOR: BLACK. REGRIND PER UL YELLOW CARD.
CONTACT BEAMS: COPPER ALLOY.
SHIELD: COPPER ALLOY.
PCB PINS: COPPER ALLOY.
- PLATING:**
CONTACT BEAMS: 1.27 μm MIN. GOLD IN CONTACT AREA OVER 3.81μm MIN NICKEL UNDERPLATE
SHIELD: NICKEL WITH SELECT TIN DIP ON TAILS.
- PRODUCT SPECIFICATION:** PS-172812-1000, APPLICATION SPECIFICATION AS-172812-1000, FOR PCB ROUTING GUIDELINES REFER TO AS-172812-1001.
- PRODUCT IS TRAY PACKAGED PER PACKAGING SPECIFICATION PK-46030-001.**
- CONFORMS TO FCC REGULATION PART 68.5 SPECIFICATION FOR MODULAR JACKS.**
- MOLEX PART NUMBER, SERIAL NUMBER AND TRACEABILITY MARK ARE LOCATED IN AREA SHOWN**
- SHIELD SURFACE FINISHES (CLASS A AND C) COMPLY WITH THE REQUIREMENTS FOR VISUAL ACCEPTANCE PER MOLEX COSMETIC SPECIFICATION ES-46030-006.**

THIS DRAWING CONTAINS INFORMATION THAT IS PROPRIETARY TO MOLEX ELECTRONIC TECHNOLOGIES, LLC AND SHOULD NOT BE USED WITHOUT WRITTEN PERMISSION									
SYMBOLS	DIMENSION UNITS	SCALE	CURRENT REV DESC: UPDATE VIEW						
▽ = 0	mm		molex 2.5GBE 2X2 ICM ASSEMBLY PRODUCT CUSTOMER DRAWING DOCUMENT NUMBER: SD-172812-3000 DOC TYPE: PSD DOC PART: 000 REVISION: B2 MATERIAL NUMBER: SEE CHART CUSTOMER: H3C SHEET NUMBER: 1 OF 6						
▽ = 0	GENERAL TOLERANCES (UNLESS SPECIFIED)								
▽ = 0	ANGULAR TOL ± 0.5°								
▽ = 0	4 PLACES ±								
▽ = 0	3 PLACES ±								
▽ = 0	2 PLACES ± 0.13								
▽ = 0	1 PLACE ± 0.25								
□ = 0	0 PLACES ±		EC NO: 176317 DRWN: AFENG02 2018/05/07 CHK'D: KLANG 2018/05/10 APPR: KLANG 2018/05/10 INITIAL REVISION: DRWN: LKATARZIENE 2016/07/13 APPR: KLANG 2016/11/22						
■ = 0	DRAFT WHERE APPLICABLE MUST REMAIN WITHIN DIMENSIONS		THIRD ANGLE PROJECTION	DRAWING	SERIES				
▽ = 0			C-SIZE	172812					

2.5GBE POE+ CIRCUIT

PCB PIN SIDE

RJ45 JACK SIDE

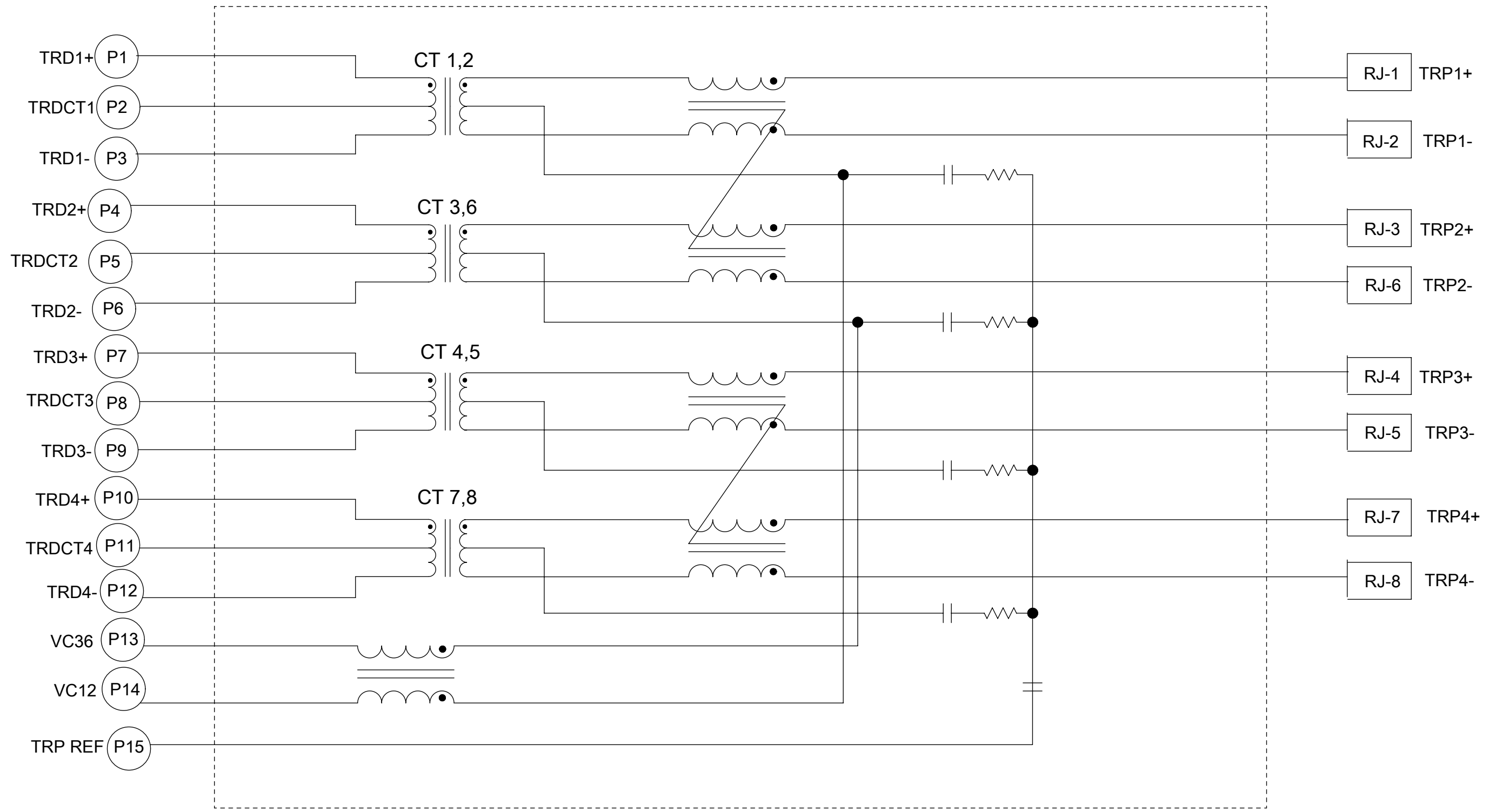

SHIELD

THIS DRAWING CONTAINS INFORMATION THAT IS PROPRIETARY TO MOLEX ELECTRONIC TECHNOLOGIES, LLC AND SHOULD NOT BE USED WITHOUT WRITTEN PERMISSION													
SYMBOLS		DIMENSION UNITS	SCALE	CURRENT REV DESC: UPDATE VIEW									
▽ = 0	▽ = 0	mm		EC NO: 176317							2.5GBE 2X2 ICM ASSEMBLY		
▽ = 0	▽ = 0	GENERAL TOLERANCES (UNLESS SPECIFIED)		DRWN: AFENG02 2018/05/07									
▽ = 0	▽ = 0	ANGULAR TOL ± 0.5°		CHK'D: KLANG 2018/05/10			PRODUCT CUSTOMER DRAWING						
▽ = 0	▽ = 0	4 PLACES ±		APPR: KLANG 2018/05/10									
▽ = 0	▽ = 0	3 PLACES ±		INITIAL REVISION:			DOCUMENT NUMBER: SD-172812-3000						
▽ = 0	▽ = 0	2 PLACES ± 0.13		DRWN: LKATARZIENE 2016/07/13									
▽ = 0	▽ = 0	1 PLACE ± 0.25		APPR: KLANG 2016/11/22			DOC TYPE: PSD DOC PART: 000 REVISION: B2						
▽ = 0	▽ = 0	0 PLACES ±		DRAFT WHERE APPLICABLE MUST REMAIN WITHIN DIMENSIONS									
▽ = 0	▽ = 0	THIRD ANGLE PROJECTION		DRAWING: C-SIZE		SERIES: 172812		MATERIAL NUMBER: SEE CHART		CUSTOMER: H3C		SHEET NUMBER: 4 OF 6	

DOCUMENT STATUS	P1	RELEASE DATE	2018/05/10	13:51:20
-----------------	----	--------------	------------	----------

2.5G 4P POE CIRCUIT

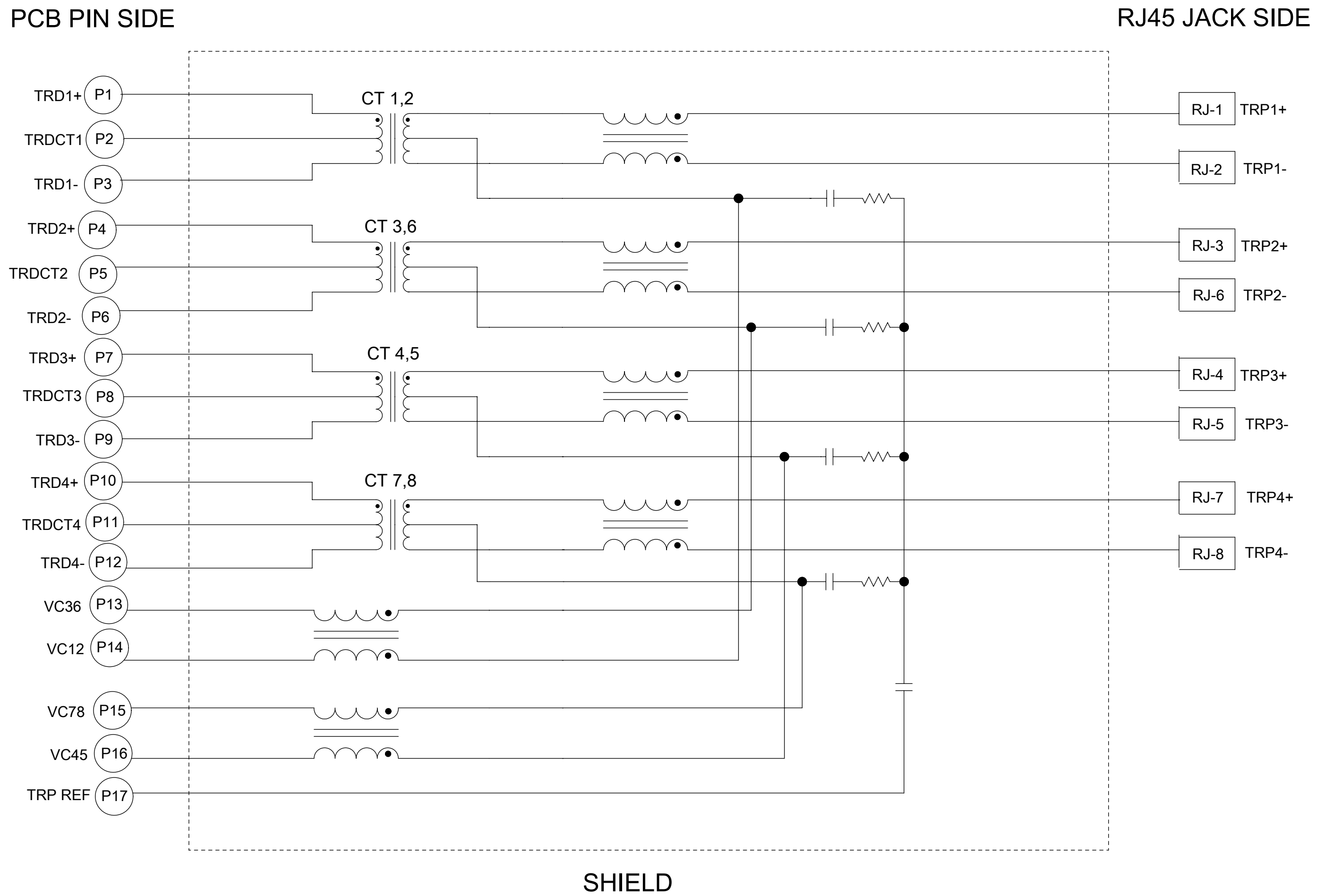

THIS DRAWING CONTAINS INFORMATION THAT IS PROPRIETARY TO MOLEX ELECTRONIC TECHNOLOGIES, LLC AND SHOULD NOT BE USED WITHOUT WRITTEN PERMISSION											
SYMBOLS		DIMENSION UNITS	SCALE	CURRENT REV DESC: UPDATE VIEW							
	= 0	mm		EC NO: 176317 DRWN: AFENG02 2018/05/07 CHK'D: KLANG 2018/05/10 APPR: KLANG 2018/05/10							2.5GBE 2X2 ICM ASSEMBLY PRODUCT CUSTOMER DRAWING
	= 0	GENERAL TOLERANCES (UNLESS SPECIFIED)					INITIAL REVISION: DRWN: LKATARZIENE 2016/07/13 APPR: KLANG 2016/11/22			DOCUMENT NUMBER	
	= 0	ANGULAR TOL ± 0.5°		DRAFT WHERE APPLICABLE MUST REMAIN WITHIN DIMENSIONS						SD-172812-3000	
	= 0	4 PLACES ±					THIRD ANGLE PROJECTION			SEE CHART	
	= 0	3 PLACES ±		C-SIZE						H3C	
	= 0	2 PLACES ± 0.13					DRAWING SERIES			172812	
	= 0	1 PLACE ± 0.25		MATERIAL NUMBER							
	= 0	0 PLACES ±					SHEET NUMBER				
	= 0			THIRD ANGLE PROJECTION							
	= 0						DRAWING SERIES				
	= 0			MATERIAL NUMBER							
	= 0						SHEET NUMBER				

POE+ ELECTRICAL CHARACTERISTIC		VALUE AT 25°C
INSERTION LOSS	1 - 170 MHz	-0.00353 (F - 0MHz) - 0.4 dB Min
	170 - 250 MHz	-0.0125 (F - 170MHz) - 1 dB Min
	250 - 400 MHz	-0.0267 (F - 250MHz) - 2 dB Min
RETURN LOSS	1 - 20 MHz	-25 dB Max
	20 - 140 MHz	12 Log ₁₀ (F/20MHz) - 25 dB Max
	140 - 250 MHz	40 Log ₁₀ (F/140MHz) - 15 dB Max
	250 - 400 MHz	22 Log ₁₀ (F/250MHz) - 5 dB Max
OPEN CIRCUIT INDUCTANCE (OCL) 0°C TO 70°C	100kHz / 0.1V / 8mA DC	450 μH MIN
	100kHz / 0.1V / 24mA DC	200 μH MIN
HI-POT		2250 VDC
COMMON MODE REJECTION	1 - 30 MHz	-30 dB Max
	30 - 200 MHz	30 Log ₁₀ (F/30MHz) - 30 dB Max
	200 - 400 MHz	-5 dB Max
MODE CONVERSION-DIFFERENTIAL CHIP TO COMMON LINE	1 - 100 MHz	-30 dB Max
	100 - 200 MHz	35 Log ₁₀ (F/100MHz) - 30 dB Max
	200 - 400 MHz	8 Log ₁₀ (F/200MHz) - 19.6 dB Max
MODE CONVERSION-DIFFERENTIAL CHIP TO COMMON CHIP	1 - 30 MHz	-25 dB Max
	30 - 200 MHz	12 Log ₁₀ (F/30MHz) - 25 dB Max
	200 - 400 MHz	-15 dB Max
IMPEDANCE BALANCE	1 - 30 MHz	-35 dB Max
	30 - 400 MHz	15 Log ₁₀ (F/30MHz) - 35 dB Max

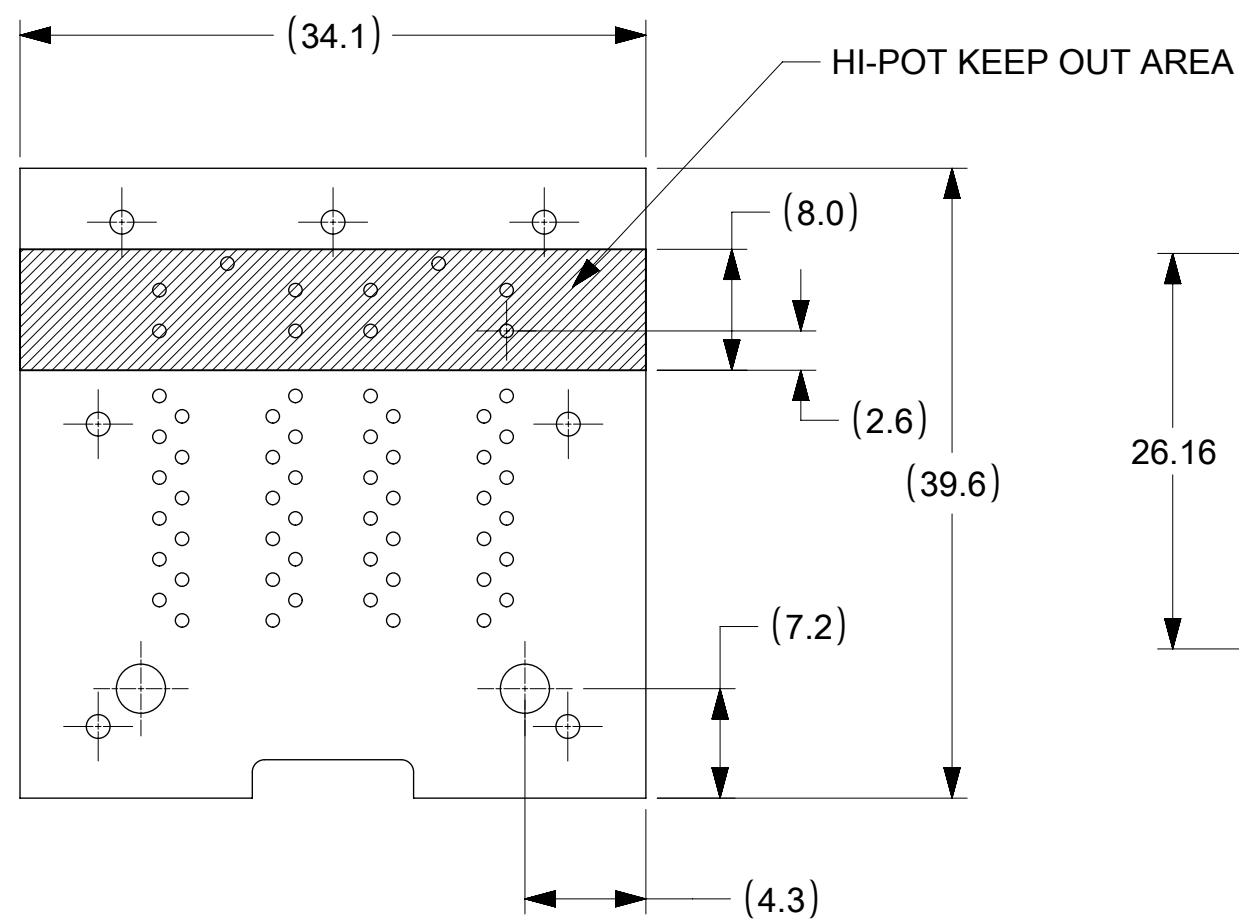
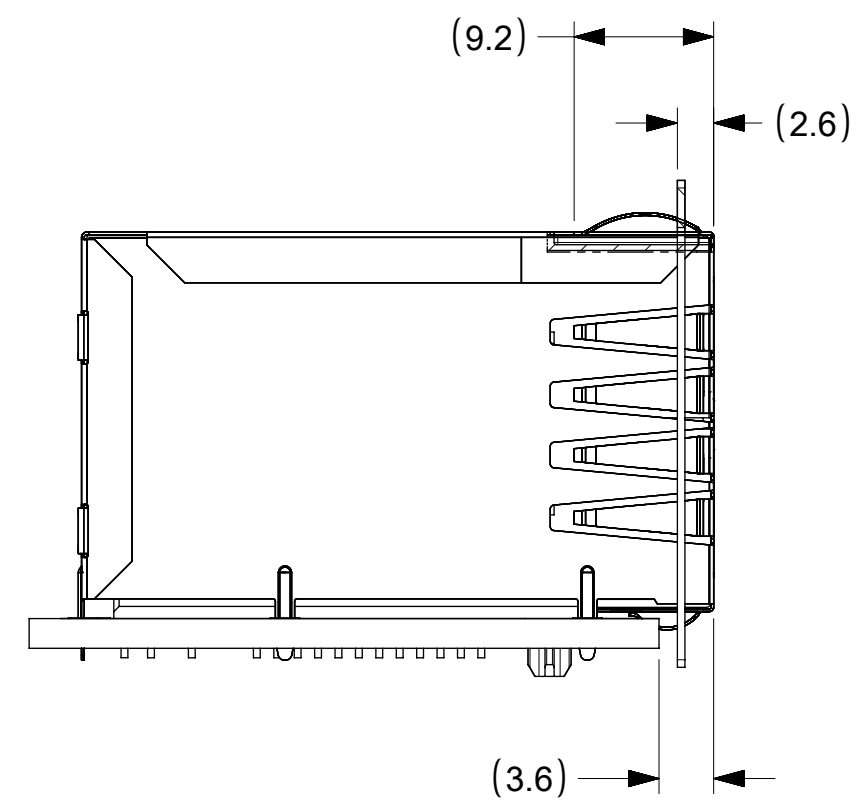

RECOMMENDED KEEP OUT AREA
PCB TOP SIDE

AREA IS RECOMMENDED TO BE CLEAR OF VIA HOLES OR COMPONENT PADS

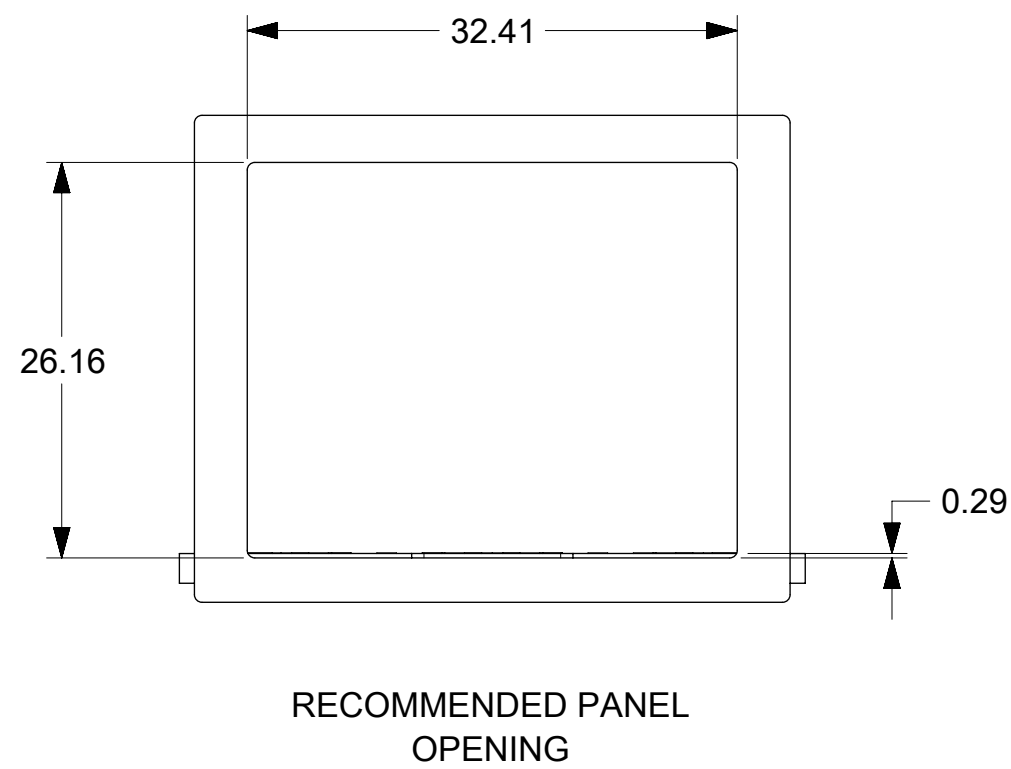

RECOMMENDED PANEL OPENING

SERIAL NUMBER LEGEND

2XZADDDYNNNNNNNQ

PORT SIZE
4 - 2X4

PART TYPE
A - ASSEMBLY

MANUFACTURING DATE CODE
(JULIAN DATE)
1-366 - DAY OF YEAR NUMBER
0-9 - ONE DIGIT YEAR

SERIAL NUMBER
1-199999 - NUMBER OF ASSEMBLY
MARKED PER DAY

TRACEABILITY MARK
P - PROTOTYPE PART
D - DEVIATED PART
OMIT FOR PRODUCTION PART

ADDITIONAL TRACEABILITY MARK

THIS DRAWING CONTAINS INFORMATION THAT IS PROPRIETARY TO MOLEX ELECTRONIC TECHNOLOGIES, LLC AND SHOULD NOT BE USED WITHOUT WRITTEN PERMISSION											
SYMBOLS		DIMENSION UNITS	SCALE	CURRENT REV DESC: UPDATE VIEW				molex			
▽ = 0	mm			EC NO: 176317				2.5GBE 2X2 ICM ASSEMBLY			
▽ = 0	GENERAL TOLERANCES (UNLESS SPECIFIED)			DRWN: AFENG02 2018/05/07							
▽ = 0	ANGULAR TOL ± 0.5°			CHK'D: KLANG 2018/05/10				PRODUCT CUSTOMER DRAWING			
▽ = 0	4 PLACES ±			APPR: KLANG 2018/05/10							
▽ = 0	3 PLACES ±			INITIAL REVISION:				DOCUMENT NUMBER			
▽ = 0	2 PLACES ± 0.13			DRWN: LKATARZIENE 2016/07/13				SD-172812-3000			
▽ = 0	1 PLACE ± 0.25			APPR: KLANG 2016/11/22				DOC TYPE DOC PART REVISION			
▽ = 0	0 PLACES ±			DRAFT WHERE APPLICABLE MUST REMAIN WITHIN DIMENSIONS				PSD 000 B2			
▽ = 0	THIRD ANGLE PROJECTION			DRAWING SERIES				MATERIAL NUMBER CUSTOMER SHEET NUMBER			
▽ = 0				C-SIZE 172812				SEE CHART H3C 6 OF 6			