

PARTS LIST

ITEM	PART NUMBER	DESCRIPTION	QTY	BASE UNIT
1	03DP-100-026	Clip	1	Each
2	03DP-100-027	Reinforcing Clip	1	Each

REVISION		DESCRIPTION
REV	DATE	
A	11/10/2008	000531ER - RELEASE PER SALES RELEASE EM998 LDL

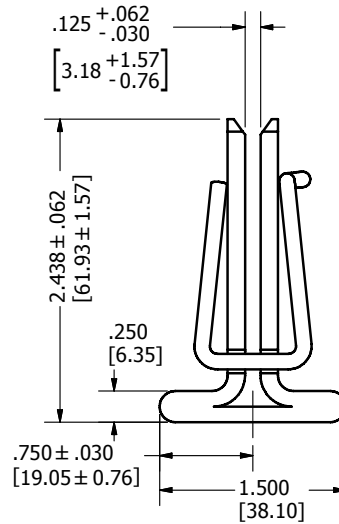
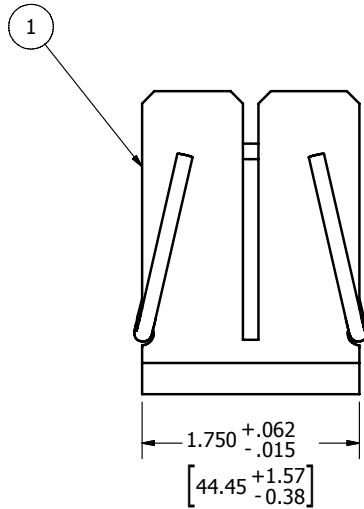
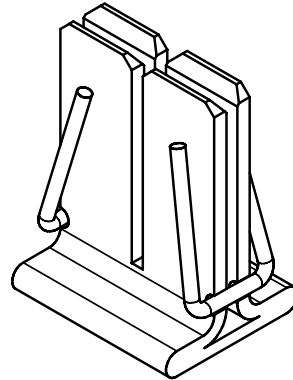
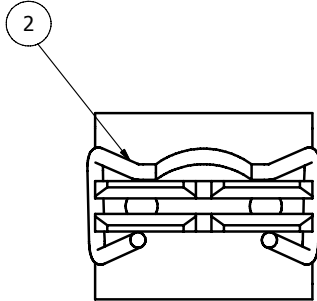

●	DENOTES CRITICAL CHARACTERISTICS.		
CPK	DENOTES CPK DIMENSIONS, -MINIMUM CPK VALUE		
(ST)	DENOTES A CHARACTERISTIC THAT PROVIDES AN INDICATION OF PROCESS PERFORMANCE. PROCEDURE FOR MEASUREMENT AND TRACKING TO BE DEFINED IN LITTELFUSE INSPECTION INSTRUCTIONS.		
CP	DENOTES CP DIMENSIONS, -MINIMUM CP VALUE MUST BE WITHIN THE DIMENSIONAL LIMITATIONS SHOWN ON DRAWING AND INITIALLY LOCATED TO ALLOW FOR MAXIMUM TOOL LIFE.		
MATL SPEC		FINISH	
DRW llogan	DATE 11/10/2008	SCALE 1:1	FINISH GOOD WT GRAMS/PIECE
UNLESS OTHERWISE SPECIFIED, DIMENSIONS ARE IN MILLIMETERS, DIMENSIONS IN BRACKETS [] ARE INCHES DIMENSIONING AND DO NOT INCLUDE PLATING. TOLERANCING TO BE INTERPRETED IN ACCORDANCE WITH ANSI Y14.5M-1994			
3RD ANGLE PROJECTION	TOLERANCE UNLESS OTHERWISE SPECIFIED ONE PLACE DEC ± .25 [.01] FRACTION ± TWO PLACE DEC ± .100 [.004] ANGULAR ±1°		
TITLE 400A FUSE CLIP			
 DES PLAINES, ILLINOIS 60016		REVISION A	DRWG NO. LF400CLIP
			SHEET 1 OF 1