



ANATECH ELECTRONICS INC
RF & Microwave Filters & Products

1877 MHz Ceramic Band Pass Filter

Part Number: AM1877B1405



Electrical Specifications

Center Frequency: 1877 MHz
Bandwidth: 10 MHz
Pass Band: 1872-1882 MHz
Insertion Loss in BW: 2.2 dB Max
Ripple in BW: 0.5 dB Max
Return Loss in BW: 14 dB Min
Attenuation: >40 dB @ 1792 MHz
 >40 dB @ 1962 MHz
In/Out Impedance: 50 Ω
Input Power: 1 W Avg

Mechanical

Mounting Method: SMT
Dimensions: 19 x 17 x 7 mm

Environmental

Operating Temperature: -40 to +85° C
Storage Temperature: -50 to +95° C
Shock: 20 G. 11 ms
Vibration: 20 G. 5 to 200 MHz

This product is RoHS compliant.

Outline Drawing:

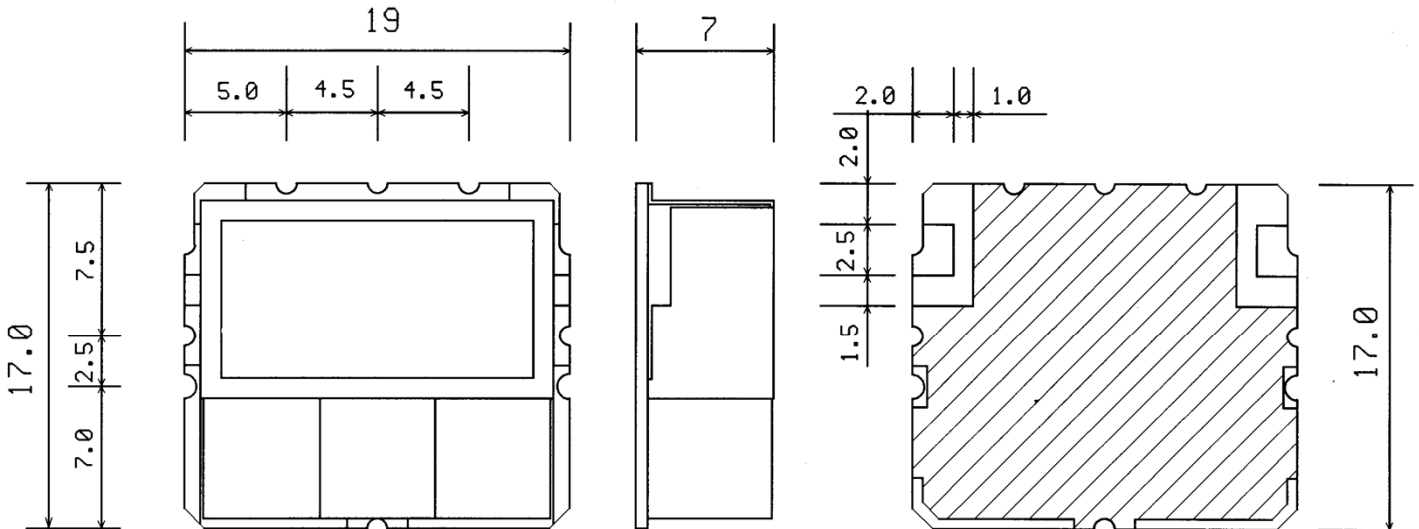

Unit:mm
 Tolerance : +/- 0.3