

Specifications:

- Current Rating:9.0 AC/DC
- Voltage Rating:600V AC/DC
- Contact Resistance:10m ohm. max.
- Withstanding Voltage:1,500V AC/minute
- Operating Temperature Range:-40°C~+105°C
- Application Wires:AWG16 to 28
- Material and Finish
- Contact:Phosphor Bronze
- Finish:Tin Plated
- Packing:See Table

Part No	Wire Apply	A	B	C	D	Q'ty/Reel
4281F1618-99	16-18AWG	3.6	4.5	2.3	2.7	4,000Pcs
4281F1822-99	18-22AWG	3.6	4.5	1.9	2.3	4,000Pcs
4281F2428-99	24-28AWG	2.3	2.3	1.8	1.65	5,000Pcs

RoHS Compliant

REV	DATE	FILE	BY

DRAWN:  
CHECKED:  
APPROVAL:

GENERAL TOLERANCE:  
.X=±0.20  
.XX=±0.15

UNIT: MM  
SCALE:1:1  
SHEET: 1 / 2  
PROJECTION:

**CnC Tech**  
Industrial Cable and Connector Technology

DESCRIPTION:  
FEMALE TERMINAL MATES W/MALE HOUSING  
4282 SERIES,PHOSPHOR BRONZE, CRIMP TIN

PART NO:  
4281F-XXXX-99

SIZE  
A4

A  
B  
C  
D

1

2

3

4

5

Front View (A)

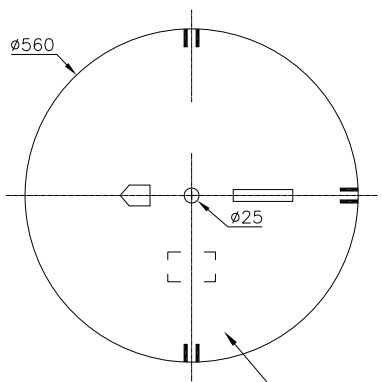

Back View

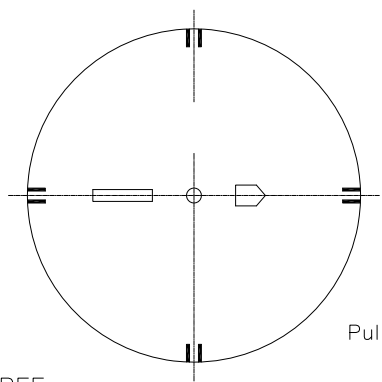

(B)

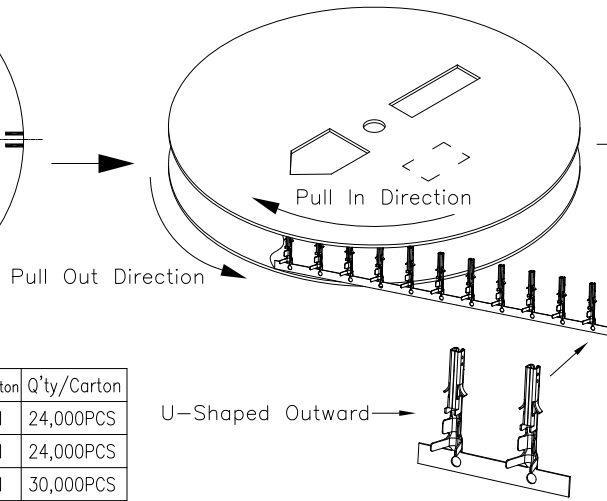

(C)

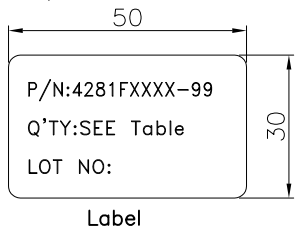
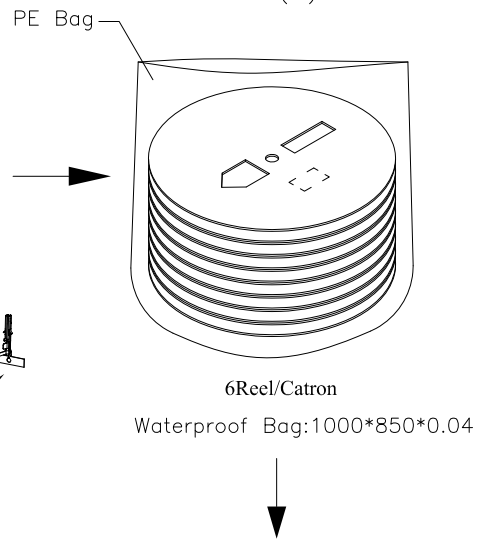

P/N:4281FXXXX-99  
 Q'TY:SEE Table  
 LOT NO:

Label

Part No	Q'ty/Reel	Reel/Carton	Q'ty/Carton
4281F1618-99	4,000PCS	6Reel	24,000PCS
4281F1822-99	4,000PCS	6Reel	24,000PCS
4281F2428-99	5,000PCS	6Reel	30,000PCS

Package Quantity

(E)

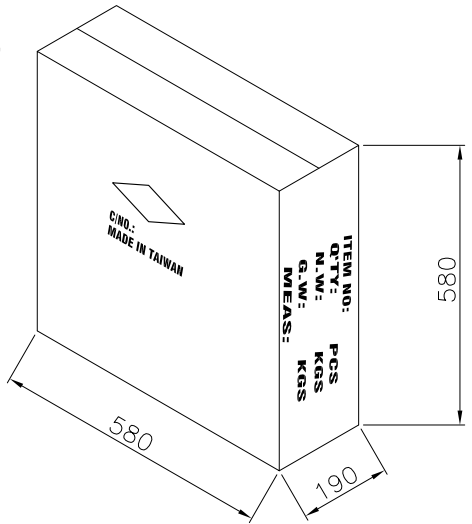

(D)

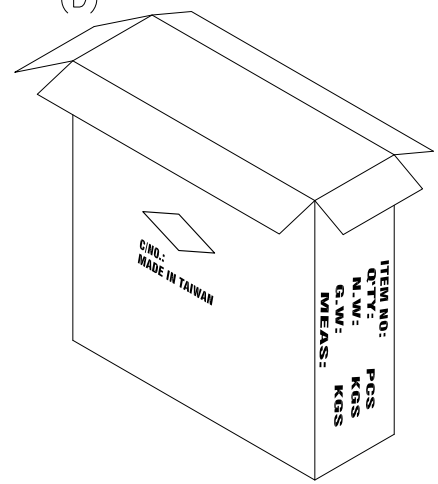

Note :  
 A.Reel packing Size:φ560\*25, A=A, T=5mm; Paper shaft Size:φ100\*22,T=8mm  
 B.Direction all the same as (Picture B), only available after plating, separate each layer of terminal by putting paper between it.  
 C.Put styrofoam inside to avoid defective terminal, attach label on each tray then place into PE bag.  
 D.Seal carton and attach carton label

RoHS Compliant

REV	DAIE	FILE	BY
-----	------	------	----

DRAWN:
CHECKED:
APPROVAL:

GENERAL TOLERANCE: .X=±0.20 .XX=±0.15
UNIT: MM
SCALE: 1:1
SHEET: 2 / 2
PROJECTION:

<b>CnC Tech</b> Industrial Cable and Connector Technology	
DESCRIPTION: FEMALE TERMINAL MATES W/MALE HOUSING 4282 SERIES,PHOSPHOR BRONZE, CRIMP TIN PACKING	SIZE A4
PART NO: 4281F-XXXX-99	

A

B

C

D