

PI6C557-03A

PCIe 2.0 Clock Generator with 2 HCSL Outputs

Features

- PCIe® 2.0 compliant
 - Phase jitter - 2.1ps RMS (typ)
- LVDS compatible outputs
- Supply voltage of 3.3V ±10%
- 25MHz crystal or clock input frequency
- HCSL outputs, 0.8V Current mode differential pair
- Jitter 35ps cycle-to-cycle (typ)
- Spread of -0.5%, -0.75%, and no spread
- Industrial temperature range
- Spread Bypass option available
- Spread and frequency selection via external pins
- Totally Lead-Free & Fully RoHS Compliant (Notes 1 & 2)
- Halogen and Antimony Free. “Green” Device (Note 3)
- Packaging: (Pb-free and Green)
 - 16-pin TSSOP (L16)
 - 16-pin QSOP (Q16)

Description

The PI6C557-03A is a spread spectrum clock generator compliant to PCI Express® 2.0 and Ethernet requirements. The device is used for PC or embedded systems to substantially reduce Electro-magnetic Interference (EMI).

The PI6C557-03A provides two differential (HCSL) or LVDS spread spectrum outputs. The PI6C557-03A is configured to select spread and clock selection. Using Pericom's patented Phase-Locked Loop (PLL) techniques, the device takes a 25MHz crystal input and produces two pairs of differential outputs (HCSL) at 25MHz, 100MHz, 125MHz and 200MHz clock frequencies. It also provides spread selection of -0.5%, -0.75%, and no spread.

Block Diagram

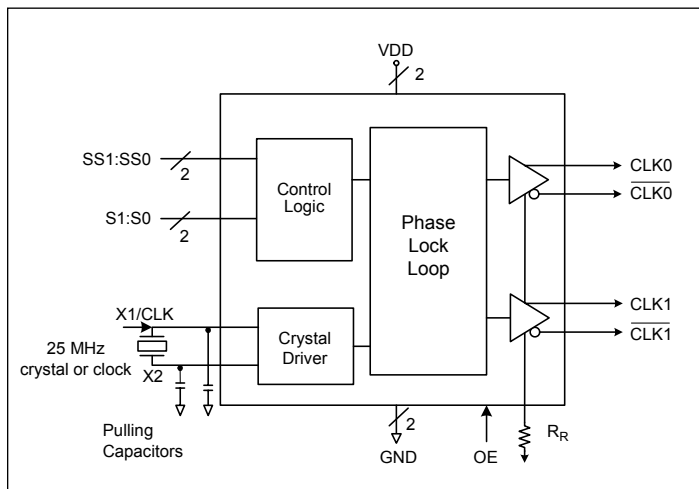

Pin Configuration (16-Pin TSSOP)

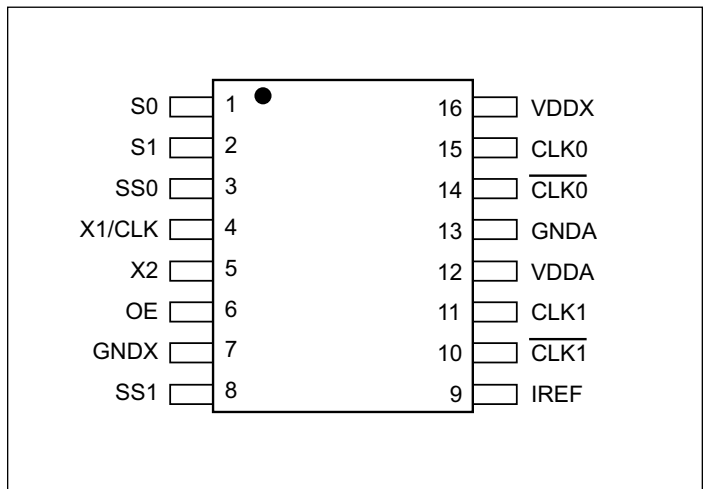

Notes:

1. No purposely added lead. Fully EU Directive 2002/95/EC (RoHS), 2011/65/EU (RoHS 2) & 2015/863/EU (RoHS 3) compliant.
2. See <https://www.diodes.com/quality/lead-free/> for more information about Diodes Incorporated's definitions of Halogen- and Antimony-free, "Green" and Lead-free.
3. Halogen- and Antimony-free "Green" products are defined as those which contain <900ppm bromine, <900ppm chlorine (<1500ppm total Br + Cl) and <1000ppm antimony compounds.

PI6C557-03A

Pin Description

Pin #	Pin Name	I/O Type	Description
1	S0	Input	Select pin 0 (Internal pull-up resistor). See Table 1.
2	S1	Input	Select pin 1 (Internal pull-up resistor). See Table 1.
3	SS0	Input	Spread Select pin 0 (Internal pull-up resistor). See Table 2.
4	X1/CLK	Input	Crystal or clock input. Connect to a 25MHz crystal or single ended clock.
5	X2	Output	Crystal connection. Leave unconnected for clock input.
6	OE	Input	Output enable. Internal pull-up resistor.
7	GNDX	Power	Crystal ground pin.
8	SS1	Input	Spread Select pin 1 (Internal pull-up resistor). See Table 2.
9	IREF	Output	Precision resistor attached to this pin is connected to the internal current reference.
10	$\overline{\text{CLK1}}$	Output	HCSL compliment clock output
11	CLK1	Output	HCSL clock output
12	VDDA	Power	Connect to a +3.3V source.
13	GND A	Power	Output and analog circuit ground.
14	$\overline{\text{CLK0}}$	Output	HCSL compliment clock output
15	CLK0	Output	HCSL clock output
16	VDDX	Power	Connect to a +3.3V source.

Table 1: Output Frequency Select Table

S1	S0	CLK(MHz)
0	0	25
0	1	100
1	0	125
1	1	200

Table 2: Spread Selection Table

SS1	SS0	Spread
0	0	No Spread
0	1	Down -0.5
1	0	Down -0.75
1	1	No Spread

Application Information

Decoupling Capacitors

Decoupling capacitors of 0.01μF should be connected between each V_{DD} pin and the ground plane and placed as close to the V_{DD} pin as possible.

Crystal

Use a 25MHz fundamental mode parallel resonant crystal with less than 300PPM of error across temperature.

Crystal Capacitors

C_L = Crystals's load capacitance in pF

Crystal Capacitors (pF) = $(C_L - 8) * 2$

For example, for a crystal with 16pF load caps, the external effective crystal cap would be 16 pF. $(16-8)*2=16$.

Current Source (IREF) Reference Resistor - R_R

If board target trace impedance is 50Ω, then $R_R = 475\Omega$ providing an IREF of 2.32 mA. The output current (I_{OH}) is 6*IREF.

Output Termination

The PCI Express differential clock outputs of the PI6C557-03A are open source drivers and require an external series resistor and a resistor to ground. These resistor values and their allowable locations are shown in detail in the PCI Express Layout Guidelines section.

The PI6C557-03A can be configured for LVDS compatible voltage levels. See the LVDS Compatible Layout Guidelines section.

Output Structures

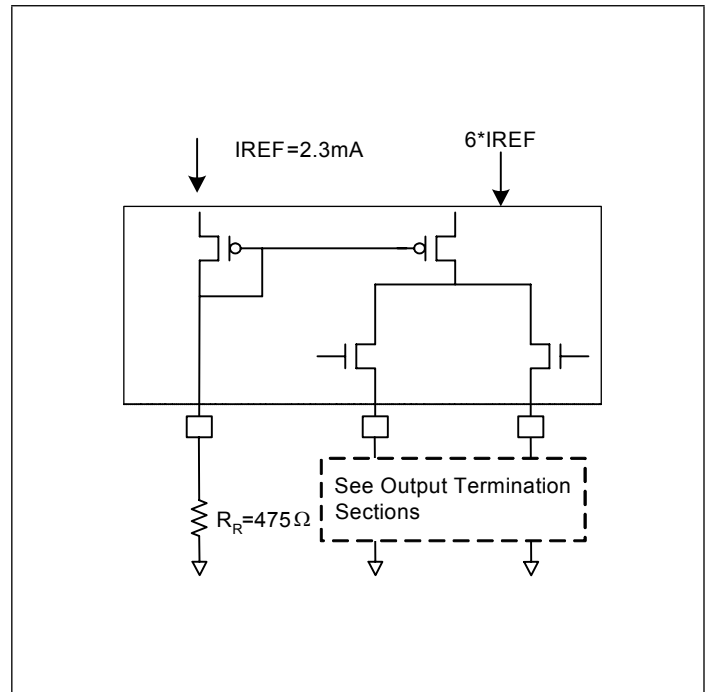

PCI Express Layout Guidelines

Common Recommendations for Differential Routing	Dimension or Value	Unit
L1 length, route as non-coupled 50Ω trace.	0.5 max	inch
L2 length, route as non-coupled 50Ω trace.	0.2 max	inch
L3 length, route as non-coupled 50Ω trace.	0.2 max	inch
R _S	33	Ω
R _T	49.9	Ω

Differential Routing on a Single PCB	Dimension or Value	Unit
L4 length, route as coupled microstrip 100Ω differential trace.	2 min to 16 max	inch
L4 length, route as coupled stripline 100Ω differential trace.	1.8 min to 14.4 max	inch

Differential Routing to a PCI Express connector	Dimension or Value	Unit
L4 length, route as coupled microstrip 100Ω differential trace.	0.25 min to 14 max	inch
L4 length, route as coupled stripline 100Ω differential trace.	0.225 min to 12.6 max	inch

PCI Express Device Routing

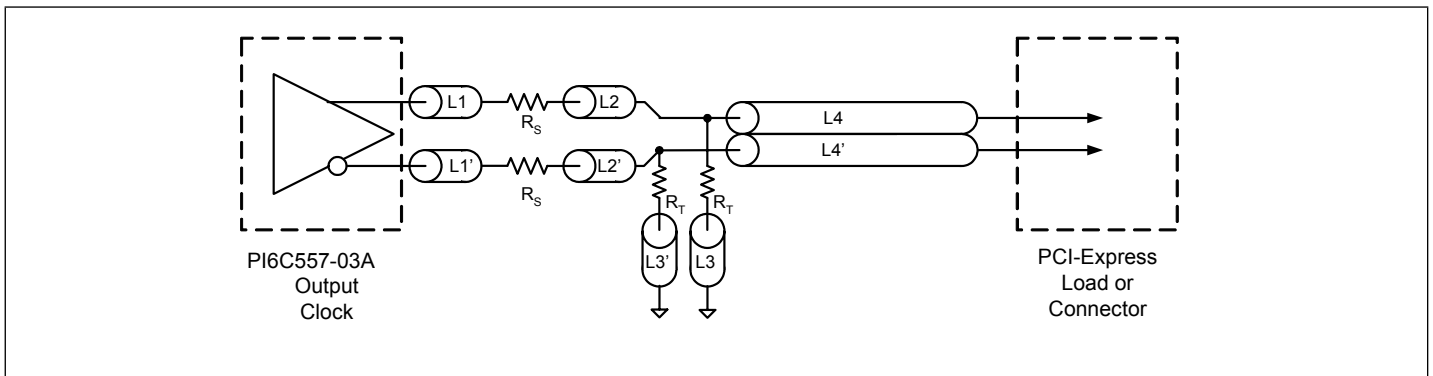

Typical PCI Express (HCSL) Waveform

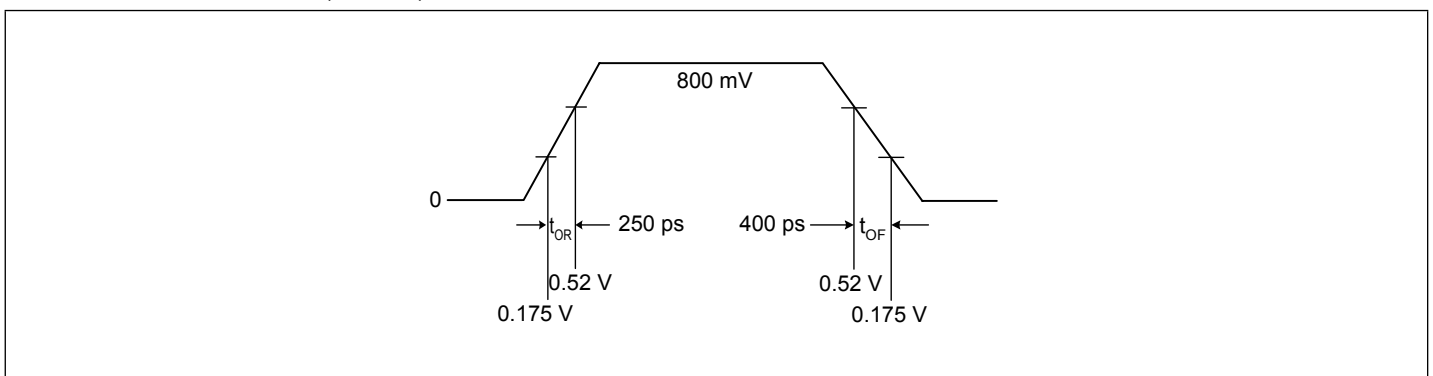

Application Information

LVDS Recommendations for Differential Routing	Dimension or Value	Unit
L1 length, route as non-coupled 50Ω trace.	0.5 max	inch
L2 length, route as non-coupled 50Ω trace.	0.2 max	inch
RP	100	Ω
RQ	100	Ω
RT	150	Ω
L3 length, route as 100Ω differential trace.		
L3 length, route as 100Ω differential trace.		

LVDS Device Routing

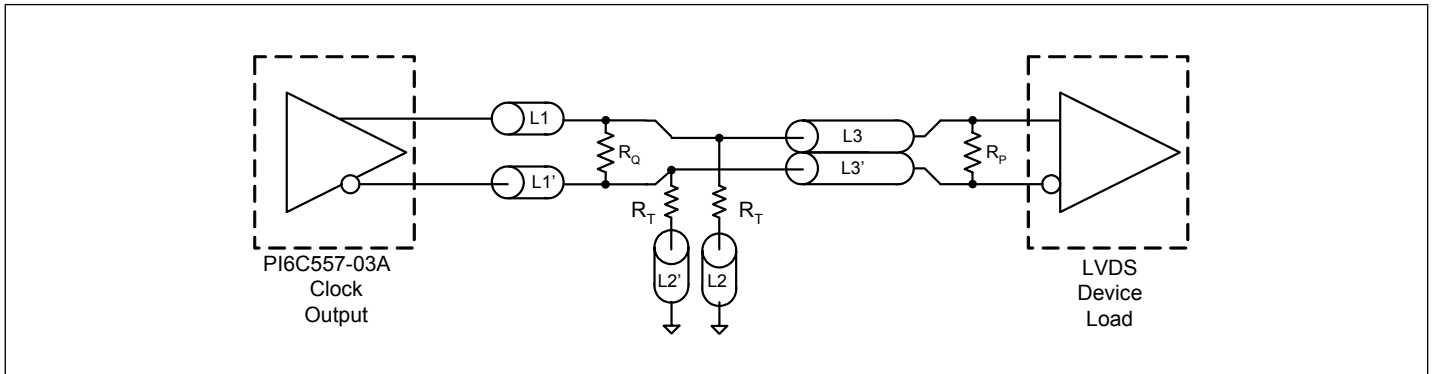

Maximum Ratings

(Above which useful life may be impaired. For user guidelines, not tested.)

Supply Voltage to Ground Potential	5.5V
All Inputs and Outputs	-0.5V to $V_{DD}+0.5V$
Ambient Operating Temperature	-40 to +85°C
Storage Temperature	-65 to +150°C
Junction Temperature	150°C
Soldering Temperature	260°C
ESD Protection (Input)	2000 V min (HBM)

Note:

Stresses greater than those listed under MAXIMUM RATINGS may cause permanent damage to the device. This is a stress rating only and functional operation of the device at these or any other conditions above those indicated in the operational sections of this specification is not implied. Exposure to absolute maximum rating conditions for extended periods may affect reliability.

Electrical Specifications

Recommended Operation Conditions

Parameter	Min.	Typ.	Max.	Unit
Ambient Operating Temperature	-40		+85	°C
Power Supply Voltage (measured in respect to GND)	+3.0		+3.6	V

DC Characteristics ($V_{DD} = 3.3V \pm 10\%$, $T_A = -40^\circ C$ to $+85^\circ C$)

Symbol	Parameter	Conditions	Min.	Typ.	Max.	Unit
V_{DD}	Supply Voltage		3.0	3.3	3.6	V
V_{IH}	Input High Voltage ⁽¹⁾	OE	2.0		$V_{DD} + 0.3$	V
V_{IL}	Input Low Voltage ⁽¹⁾	OE	GND - 0.3		0.8	V
I_{IL}	Input Leakage Current	$0 < V_{in} < V_{DD}$	With input pull-up and pull-downs	-20	20	μA
			Without input pull-up and pull-downs	-5	5	
I_{DD}	Operating Supply Current	$R_L = 50\Omega$, $C_L = 2pF$			95	mA
I_{DDOE}		OE = LOW			50	mA
C_{IN}	Input Capacitance	@ 55MHz			7	pF
C_{OUT}	Output Capacitance	@ 55MHz			6	pF
L_{PIN}	Pin Inductance				5	nH
R_{OUT}	Output Resistance	CLK Outputs	3.0			kΩ

Notes:

- Single edge is monotonic when transitioning through region.

HCSL Output AC Characteristics ($V_{DD} = 3.3V \pm 10\%$, $T_A = -40^\circ C$ to $+85^\circ C$)

Symbol	Parameter	Conditions	Min.	Typ.	Max.	Unit
F_{IN}	Input Frequency			25		MHz
V_{OUT}	Output Frequency		25		200	MHz
V_{OH}	Output High Voltage ^(1,2)	100 MHz HCSL output @ $V_{DD} = 3.3V$	660	800	900	mV
V_{OL}	Output Low Voltage ^(1,2)		-150	0		mV
V_{CPA}	Crossing Point Voltage ^(1,2)	Absolute	250	350	550	mV
V_{CN}	Crossing Point Voltage ^(1,2,4)	Variation over all edges			140	mV
J_{CC}	Jitter, Cycle-to-Cycle ^(1,3)			35	60	ps
J_{RMS}	PCIe RMS Jitter	PCIe 2.0 Test Method @ 100MHz Output			3.1	ps
MF	Modulation Frequency	Spread Spectrum	30	31.5	33	kHz
t_{OR}	Rise Time ^(1,2)	From 0.175V to 0.525V	175		500	ps
t_{OF}	Fall Time ^(1,2)	From 0.525V to 0.175V	175		500	ps
T_{SKEW}	Skew between outputs	At Crossing Point Voltage			50	ps
$T_{DUTY-CYCLE}$	Duty Cycle ^(1,3)		45		55	%
T_{OE}	Output Enable Time ⁽⁵⁾	All outputs			10	μs
T_{OT}	Output Disable Time ⁽⁵⁾	All outputs			10	μs
t_{STABLE}	From power-up to $V_{DD}=3.3V$	From Power-up $V_{DD}=3.3V$		3.0		ms
t_{SPREAD}	Setting period after spread change	Setting period after spread change		3.0		ms

Notes:

- $R_L = 50\text{-Ohm}$ with $C_L = 2\text{ pF}$
- Single-ended waveform
- Differential waveform
- Measured at the crossing point
- CLK pins are tri-stated when OE is LOW

Thermal Characteristics

Symbol	Parameter	Conditions	Min.	Typ.	Max.	Unit
θ_{JA}	Thermal Resistance Junction to Ambient	Still air			90	$^\circ C/W$
θ_{JC}	Thermal Resistance Junction to Case				24	$^\circ C/W$

Recommended Crystal Specification

Pericom recommends:

- GC2500003 XTAL 49S/SMD(4.0 mm), 25M, $CL=18\text{pF}$, $\pm 30\text{ppm}$
http://www.pericom.com/pdf/datasheets/se/GC_GF.pdf
- FY2500081, SMD 5x3.2(4P), 25M, $CL=18\text{pF}$, $\pm 30\text{ppm}$
http://www.pericom.com/pdf/datasheets/se/FY_F9.pdf
- FL2500047, SMD 3.2x2.5(4P), 25M, $CL=18\text{pF}$, $\pm 20\text{ppm}$
<http://www.pericom.com/pdf/datasheets/se/FL.pdf>

PI6C557-03A

Part Marking

L Package

PI6C557
-03ALE
ZYYWWXX
○

Z: Die Rev
YY: Year
WW: Workweek
1st X: Assembly Code
2nd X: Fab Code

L Package—2017 (Au Version)

PI6C557
-03ALE
ZYYWWXX
○

Z: Die Rev
YY: Year
WW: Workweek
1st X: Assembly Code
2nd X: Fab Code

Q Package

PI6C557
-03AQE
YYWWXX
○

YY: Year
WW: Workweek
1st X: Assembly Code
2nd X: Fab Code

PI6C557-03A

Packaging Mechanical: 16-TSSOP (L)

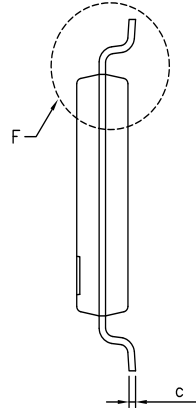
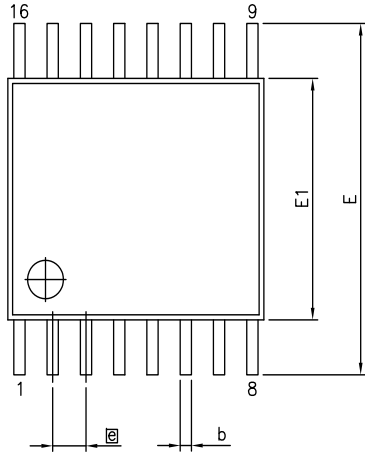

SYMBOLS	MIN.	NOM.	MAX.
A	—	—	1.20
A1	0.05	—	0.15
A2	0.80	1.00	1.05
b	0.19	—	0.30
c	0.09	—	0.20
D	4.90	5.00	5.10
E1	4.30	4.40	4.50
E	6.20	6.40	6.60
e	0.65 BSC		
L1	1.00 REF		
L	0.45	0.60	0.75
S	0.20	—	—
θ	0°	—	8°

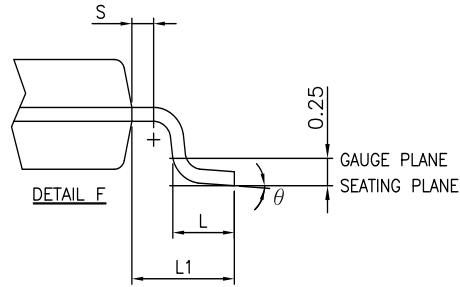
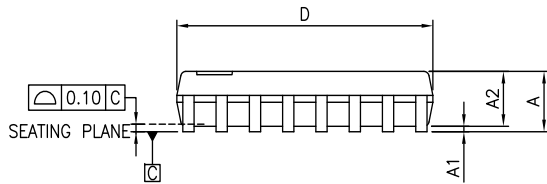

NOTES:

1. ALL DIMENSIONS IN MILLIMETERS. ANGLES IN DEGREES.
2. JEDEC MO-153F
3. DIMENSIONS DOES NOT INCLUDE MOLD FLASH, PROTRUSIONS OR GATE BURRS.



DATE: 03/24/16

DESCRIPTION: 16-Pin, 173mil Wide TSSOP

PACKAGE CODE: L (L16)

DOCUMENT CONTROL #: PD-1310

REVISION: G

16-0061

Packaging Mechanical: 16-QSOP (Q)

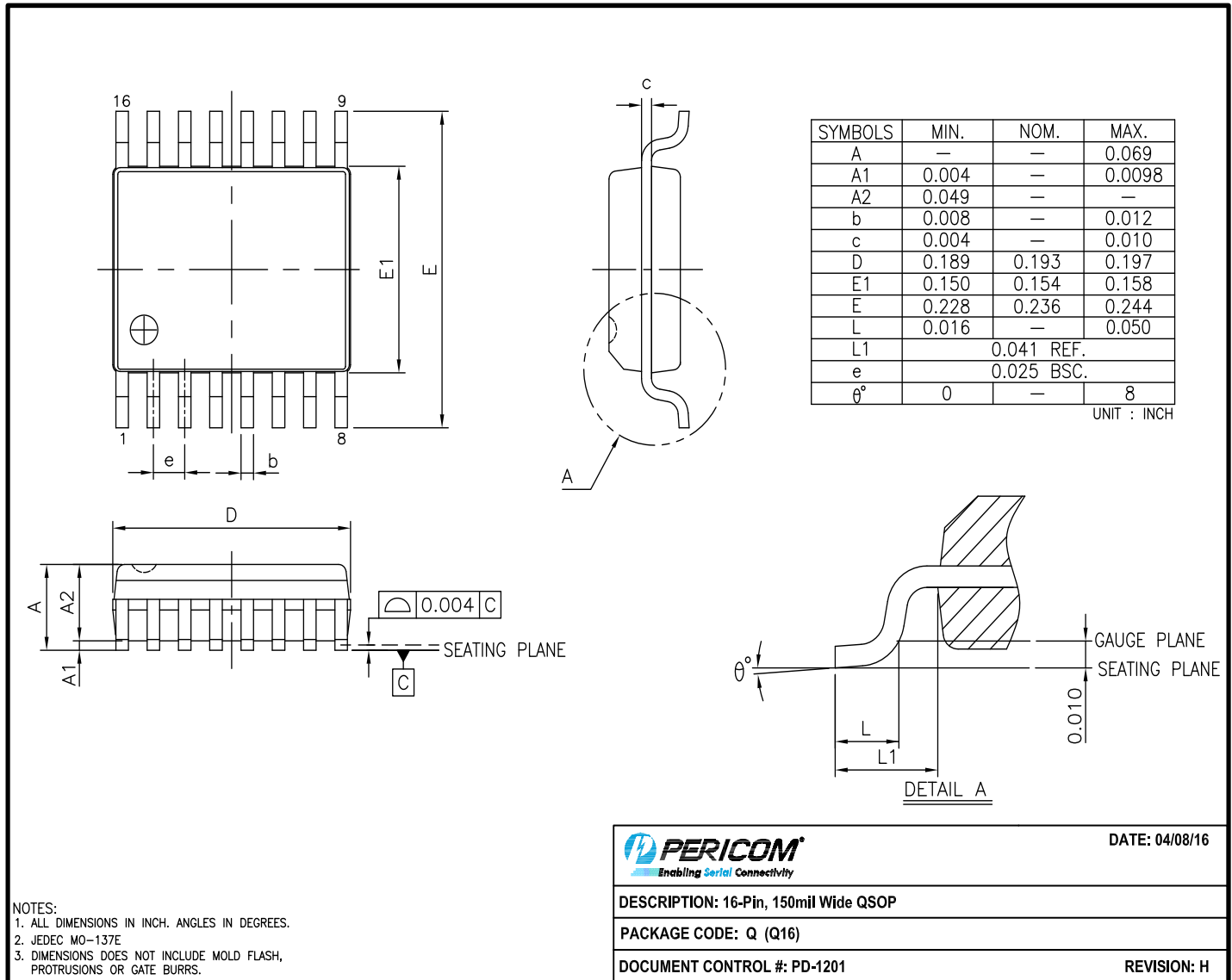

16-0056

For latest package info.

please check: <http://www.diodes.com/design/support/packaging/pericom-packaging/packaging-mechanicals-and-thermal-characteristics/>

Ordering Information

Ordering Code	Package Code	Package Type
PI6C557-03ALEX	L	16-pin, 173mil Wide (TSSOP)
PI6C557-03AQEX	Q	16-pin, 150mil Wide (QSOP)

Notes:

1. No purposely added lead. Fully EU Directive 2002/95/EC (RoHS), 2011/65/EU (RoHS 2) & 2015/863/EU (RoHS 3) compliant.
2. See <https://www.diodes.com/quality/lead-free/> for more information about Diodes Incorporated's definitions of Halogen- and Antimony-free, "Green" and Lead-free.
3. Halogen- and Antimony-free "Green" products are defined as those which contain <900ppm bromine, <900ppm chlorine (<1500ppm total Br + Cl) and <1000ppm antimony compounds.
4. E = Pb-free and Green
5. X suffix = Tape/Reel

IMPORTANT NOTICE

DIODES INCORPORATED MAKES NO WARRANTY OF ANY KIND, EXPRESS OR IMPLIED, WITH REGARDS TO THIS DOCUMENT, INCLUDING, BUT NOT LIMITED TO, THE IMPLIED WARRANTIES OF MERCHANTABILITY AND FITNESS FOR A PARTICULAR PURPOSE (AND THEIR EQUIVALENTS UNDER THE LAWS OF ANY JURISDICTION).

Diodes Incorporated and its subsidiaries reserve the right to make modifications, enhancements, improvements, corrections or other changes without further notice to this document and any product described herein. Diodes Incorporated does not assume any liability arising out of the application or use of this document or any product described herein; neither does Diodes Incorporated convey any license under its patent or trademark rights, nor the rights of others. Any Customer or user of this document or products described herein in such applications shall assume all risks of such use and will agree to hold Diodes Incorporated and all the companies whose products are represented on Diodes Incorporated website, harmless against all damages.

Diodes Incorporated does not warrant or accept any liability whatsoever in respect of any products purchased through unauthorized sales channel.

Should Customers purchase or use Diodes Incorporated products for any unintended or unauthorized application, Customers shall indemnify and hold Diodes Incorporated and its representatives harmless against all claims, damages, expenses, and attorney fees arising out of, directly or indirectly, any claim of personal injury or death associated with such unintended or unauthorized application.

Products described herein may be covered by one or more United States, international or foreign patents pending. Product names and markings noted herein may also be covered by one or more United States, international or foreign trademarks.

This document is written in English but may be translated into multiple languages for reference. Only the English version of this document is the final and definitive format released by Diodes Incorporated.

LIFE SUPPORT

Diodes Incorporated products are specifically not authorized for use as critical components in life support devices or systems without the express written approval of the Chief Executive Officer of Diodes Incorporated. As used herein:

A. Life support devices or systems are devices or systems which:

1. are intended to implant into the body, or

2. support or sustain life and whose failure to perform when properly used in accordance with instructions for use provided in the labeling can be reasonably expected to result in significant injury to the user.

B. A critical component is any component in a life support device or system whose failure to perform can be reasonably expected to cause the failure of the life support device or to affect its safety or effectiveness.

Customers represent that they have all necessary expertise in the safety and regulatory ramifications of their life support devices or systems, and acknowledge and agree that they are solely responsible for all legal, regulatory and safety-related requirements concerning their products and any use of Diodes Incorporated products in such safety-critical, life support devices or systems, notwithstanding any devices- or systems-related information or support that may be provided by Diodes Incorporated. Further, Customers must fully indemnify Diodes Incorporated and its representatives against any damages arising out of the use of Diodes Incorporated products in such safety-critical, life support devices or systems.

Copyright © 2016, Diodes Incorporated

www.diodes.com