

| PART NUMBER | REV | FIRST USED |
|-------------|-----|------------|
| 680515-1 | A | 122500-1 |
| 680515-2 | A | 565435-5 |
| 680515-3 | A | 354500-1 |

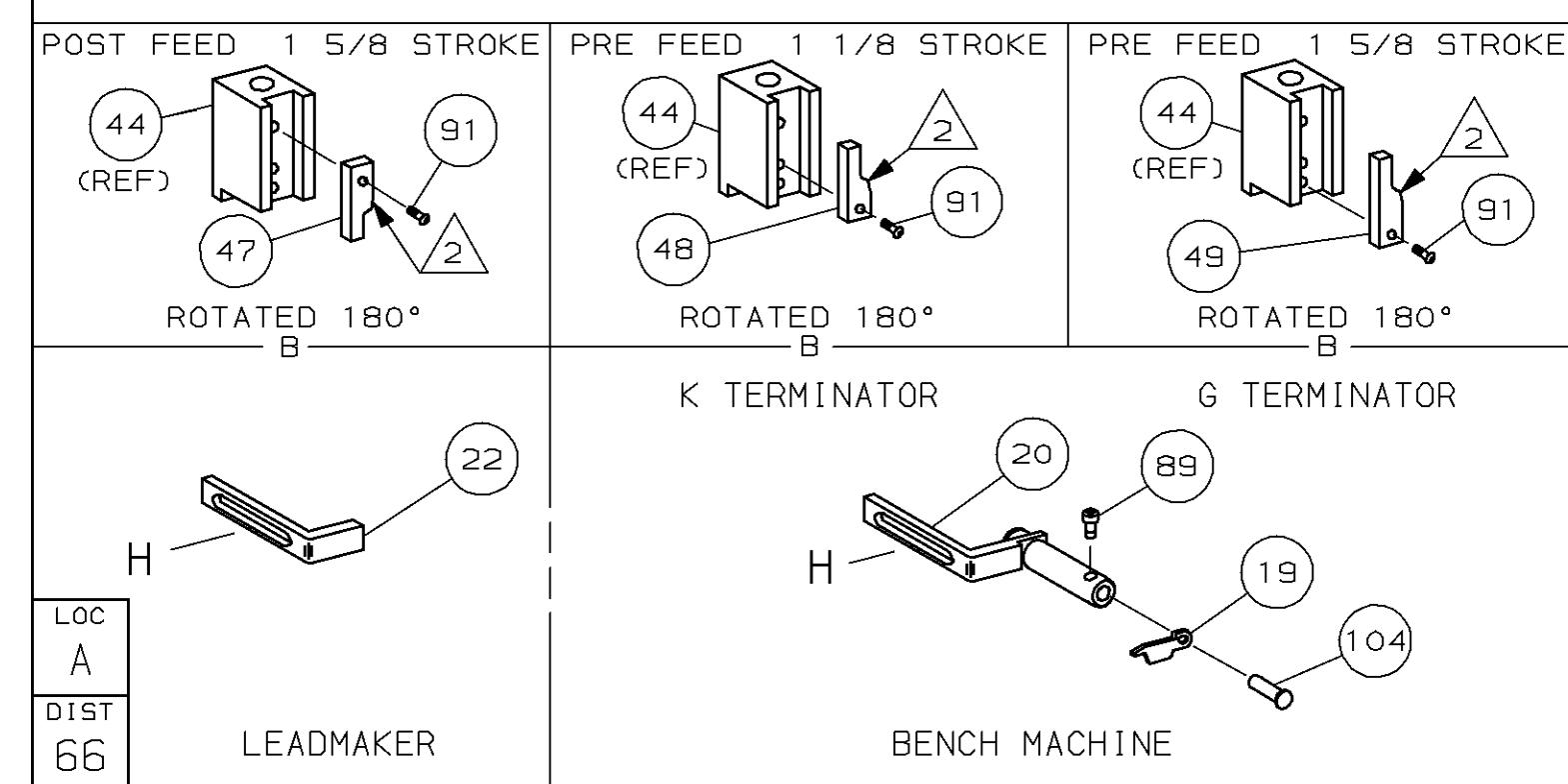
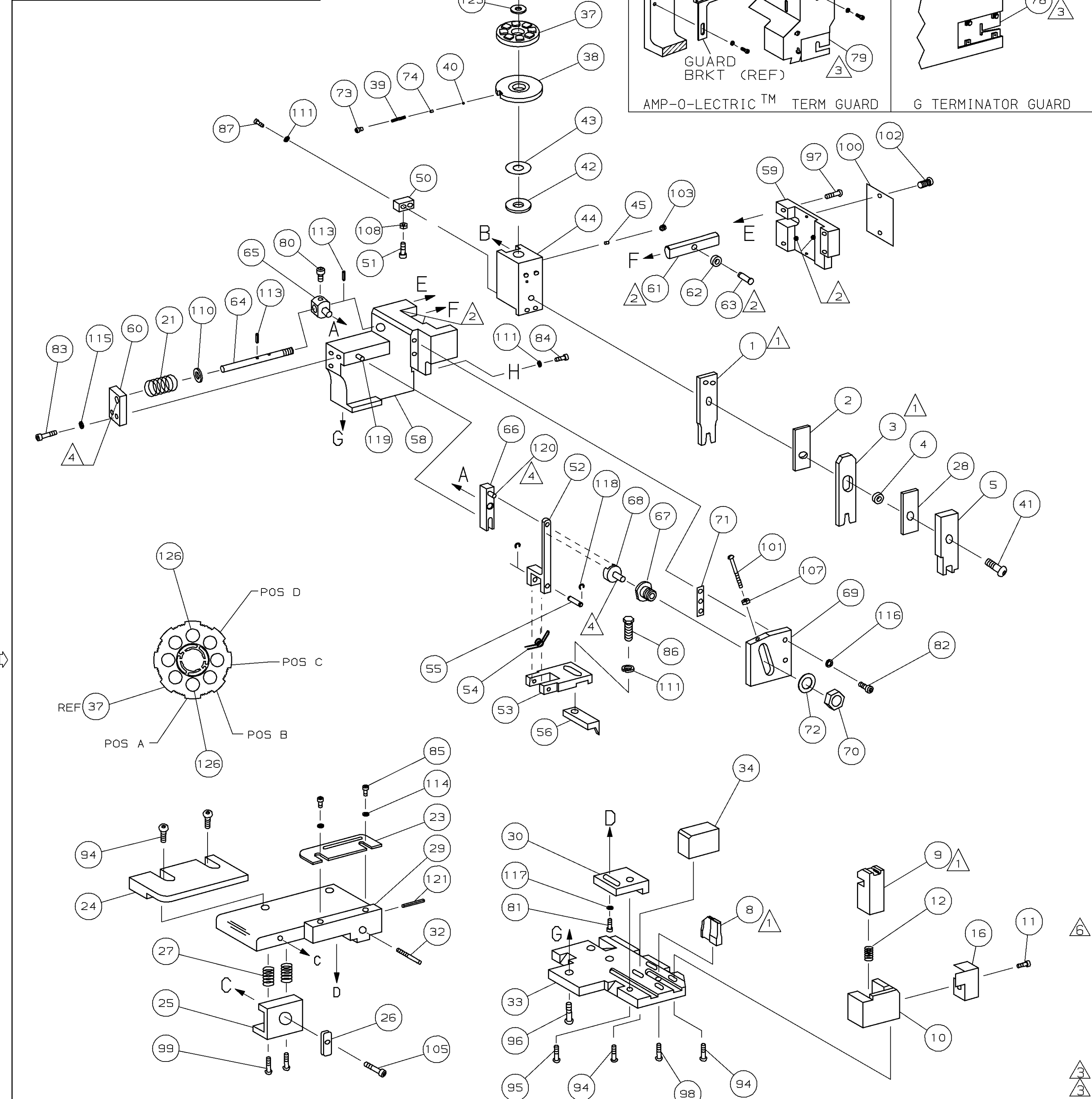

- 1 RECOMMENDED SPARE PARTS.
- 2 GREASE LIGHTLY.
- 3 GUARD MUST BE IN PLACE WHEN OPERATING APPLICATOR IN A BENCH MACHINE.
- 4 LUBRICATE DAILY USING NO. 20 MACHINE OIL.
- 5. ITEMS WITH QTY OF REF SPECIFIED (EXCEPT ITEMS 78 AND 79) ARE USED ON ITEM 46.
- 6 CUT TO LENGTH AT ASSY

| TERMINAL NAME: TERMINAL, SOCKET | | | |
|---------------------------------|---------------------------|-----------|------------------|
| 286627 | CRIMPING DATA | | |
| PAD LTR | CRIMP HEIGHT | WIRE SIZE | |
| A | .068 ±.002 [1.73 ±0.05mm] | 12 | |
| B | NOT | USED | |
| C | NOT | USED | |
| D | NOT | USED | |
| CRIMP | SIZE | TYPE | RANGE |
| WIRE | .130 [3.30mm] | F | 12 |
| INSUL | .155 [3.94mm] | 0 | φ.118-.137 |
| WIRE STRIP LENGTH | TERM APPL | SPEC | FEED |
| .203-.219 | NONE | | .520 |
| | | | APPL INSTRUCTION |
| | | | 408-8040 |
| | | | SET UP GAGE |
| | | | 458637-1 |
| | | | LAYOUT |
| | | | L1973 |

| QTY | REF | REF | REF | U/M | DWG SIZE | PART NO | DESCRIPTION | ITEM NO |
|-----|-----|-----|-----|----------|----------|------------|---------------------------------|---------|
| | | | | | | | | 129 |
| | | | | | | | | 128 |
| | | | | | | | | 127 |
| 2 | 2 | 2 | - | C | | 9-354778-3 | PIN, WIRE DISC (.2960)A | 126 |
| 1 | 1 | 1 | - | A | | 986950-1 | WASHER, FLAT PRECISION | 125 |
| 1 | 1 | 1 | - | A | | 217238-1 | GENERAL INSTRUCTION PACKAGE | 124 |
| 1 | 1 | 1 | - | - | | 4088040 | SF APPL INST 408-8040 | 123 |
| | | | | | | | | 122 |
| 1 | 1 | 1 | - | A | | 4-21028-0 | PIN,SLT SPR(φ.093x.75)ST GDE PL | 121 |
| REF | REF | REF | - | A | | 1-21030-1 | PIN,DOWL(φ.187x.50)LEVER | 120 |
| REF | REF | REF | - | A | | 1-21030-6 | PIN,DOWL(φ.187x1.25)HOUSING | 119 |
| REF | REF | REF | - | A | | 21045-3 | RING,RET "C"(φ.187)FD FING PIN | 118 |
| 1 | 1 | 1 | - | A | | 21024-5 | WASHER, LOCK (#10)ADJ BLK | 117 |
| REF | REF | REF | - | A | | 21024-5 | WASHER,LOCK(#10)ADJ PLATE | 116 |
| REF | REF | REF | - | A | | 21024-5 | WASHER,LOCK(#10)FEED GDE ROD | 115 |
| 2 | 2 | 2 | - | A | | 21024-2 | WASHER,LOCK(#4)FRONT STP GUIDE | 114 |
| REF | REF | REF | - | A | | 5-21028-1 | PIN,SLT SPR(φ.125x.50)ADJ ROD | 113 |
| | | | | | | | | 112 |
| 4 | 4 | 4 | - | A | | 21024-4 | WASHER,LOCK(#8)STRIPPER | 111 |
| REF | REF | REF | - | A | | 21899-4 | WASHER,FLAT(φ5/16)SCREW ADJ | 110 |
| | | | | | | | | 109 |
| 1 | 1 | 1 | - | A | | 21018-5 | NUT, HEX (NO. 6)HOLDDOWN | 108 |
| REF | REF | REF | - | A | | 21018-5 | NUT, HEX (6-32)FEED ADJ | 107 |
| | | | | | | | | 106 |
| 1 | 1 | 1 | - | A | | 22353-8 | SCR,SHLD(φ.187x.25)DRAG LEVER | 105 |
| 1 | 1 | - | - | A | | 992031-1 | PIN, CLEVIS | 104 |
| 1 | 1 | 1 | - | A | | 21009-2 | SCR,SKT SET(1/4-20x.25 LW)RAM | 103 |
| 2 | 2 | 2 | - | A | | 21017-2 | SCR,DRIVE(#2x.19)ID PLATE | 102 |
| REF | REF | REF | - | A | | 6-23715-5 | SCR,PAN HD(6-32x1.50)FEED ADJ | 101 |
| 1 | 1 | 1 | - | B | | 461264-1 | PLATE, IDENTIFICATION | 100 |
| 2 | 2 | 2 | - | A | | 3-21002-0 | SCR,BHC(10-32x.88)DRAG | 99 |
| 1 | 1 | 1 | - | A | | 22733-8 | SCR,BHC(8-32x.38 LW)ANVIL | 98 |
| REF | REF | REF | - | A | | 2-21002-9 | SCR,BHC(10-32x.75)CAP | 97 |
| REF | REF | REF | - | A | | 2-22733-8 | SCR,BHC(1/4-20x.62)HOUSING | 96 |
| REF | REF | REF | - | A | | 2-21002-7 | SCR,BHC(10-32x.50)SG ADJ BLOCK | 95 |
| 6 | 6 | 6 | - | A | | 2-21002-2 | SCR,BHC(8-32x.50)TERM H DWN | 94 |
| | | | | | | | | 93 |
| | | | | | | | | 92 |
| 1 | 1 | 1 | - | A | | 1-21002-7 | SCR,BHC(6-32x.38)CAM | 91 |
| | | | | | | | | 90 |
| 1 | 1 | - | - | A | | 7-21000-9 | SCR,SHC(4-40x.19)STRIPPER | 89 |
| | | | | | | | | 88 |
| 2 | 2 | 2 | - | A | | 2-21000-7 | SCR,SHC(8-32x.48)DEP-HOLD | 87 |
| 1 | 1 | 1 | - | A | | 2-22603-0 | SCR,HEX HD(8-32x.31)FEED FINGER | 86 |
| 2 | 2 | 2 | - | A | | 1-21000-3 | SCR,SHC(4-40x.25)F ST GUIDE | 85 |
| 1 | 1 | 1 | - | A | | 2-21000-7 | SCR,SHC(8-32x.50)STRIPPER | 84 |
| REF | REF | REF | - | A | | 3-21000-7 | SCR,SHC(10-32x.75)FEED ROD GD | 83 |
| REF | REF | REF | - | A | | 3-21000-6 | SCR,SHC(10-32x.62)FD ADJ BLK | 82 |
| 1 | 1 | 1 | - | A | | 3-21000-4 | SCR,SHC(10-32x.38)SG ADJ BL | 81 |
| REF | REF | REF | - | A | | 3-21000-4 | SCR,SHC(10-32x.38)PIVOT BLK | 80 |
| - | REF | - | - | B | | 455749-1 | GUARD, WINDOW | 79 |
| REF | - | - | - | B | | 679532-1 | INSERT, GUARD | 78 |
| | | | | | | | | 77 |
| | | | | | | | | 76 |
| | | | | | | | | 75 |
| 1 | 1 | 1 | - | A | | 690603-1 | SPRING, ASSIST | 74 |
| 1 | 1 | 1 | - | A | | 23030-1 | SCR,SHC(6-32x.25 SL)INS DISC | 73 |
| REF | REF | REF | - | A | | 458109-1 | WASHER, SPECIAL | 72 |
| REF | REF | REF | - | A | | 690517-1 | SPACER | 71 |
| -3 | -2 | -1 | U/M | DWG SIZE | | PART NO | DESCRIPTION | ITEM NO |

| QTY | REF | REF | REF | U/M | DWG SIZE | PART NO | DESCRIPTION | ITEM NO |
|-----|-----|-----|-----|-----|----------|---------|-------------|---------|
| | | | | | | | | 77 |
| | | | | | | | | 76 |
| | | | | | | | | 75 |
| | | | | | | | | 74 |
| | | | | | | | | 73 |
| | | | | | | | | 72 |
| | | | | | | | | 71 |

| QTY | REF | REF | REF | U/M | DWG SIZE | PART NO | DESCRIPTION | ITEM NO |
|-----|-----|-----|-----|----------|----------|------------|---------------------------------|---------|
| | | | | | | | | 129 |
| | | | | | | | | 128 |
| | | | | | | | | 127 |
| 2 | 2 | 2 | - | C | | 9-354778-3 | PIN, WIRE DISC (.2960)A | 126 |
| 1 | 1 | 1 | - | A | | 986950-1 | WASHER, FLAT PRECISION | 125 |
| 1 | 1 | 1 | - | A | | 217238-1 | GENERAL INSTRUCTION PACKAGE | 124 |
| 1 | 1 | 1 | - | - | | 4088040 | SF APPL INST 408-8040 | 123 |
| | | | | | | | | 122 |
| 1 | 1 | 1 | - | A | | 4-21028-0 | PIN,SLT SPR(φ.093x.75)ST GDE PL | 121 |
| REF | REF | REF | - | A | | 1-21030-1 | PIN,DOWL(φ.187x.50)LEVER | 120 |
| REF | REF | REF | - | A | | 1-21030-6 | PIN,DOWL(φ.187x1.25)HOUSING | 119 |
| REF | REF | REF | - | A | | 21045-3 | RING,RET "C"(φ.187)FD FING PIN | 118 |
| 1 | 1 | 1 | - | A | | 21024-5 | WASHER, LOCK (#10)ADJ BLK | 117 |
| REF | REF | REF | - | A | | 21024-5 | WASHER,LOCK(#10)ADJ PLATE | 116 |
| REF | REF | REF | - | A | | 21024-5 | WASHER,LOCK(#10)FEED GDE ROD | 115 |
| 2 | 2 | 2 | - | A | | 21024-2 | WASHER,LOCK(#4)FRONT STP GUIDE | 114 |
| REF | REF | REF | - | A | | 5-21028-1 | PIN,SLT SPR(φ.125x.50)ADJ ROD | 113 |
| | | | | | | | | 112 |
| 4 | 4 | 4 | - | A | | 21024-4 | WASHER,LOCK(#8)STRIPPER | 111 |
| REF | REF | REF | - | A | | 21899-4 | WASHER,FLAT(φ5/16)SCREW ADJ | 110 |
| | | | | | | | | 109 |
| 1 | 1 | 1 | - | A | | 21018-5 | NUT, HEX (NO. 6)HOLDDOWN | 108 |
| REF | REF | REF | - | A | | 21018-5 | NUT, HEX (6-32)FEED ADJ | 107 |
| | | | | | | | | 106 |
| 1 | 1 | 1 | - | A | | 22353-8 | SCR,SHLD(φ.187x.25)DRAG LEVER | 105 |
| 1 | 1 | - | - | A | | 992031-1 | PIN, CLEVIS | 104 |
| 1 | 1 | 1 | - | A | | 21009-2 | SCR,SKT SET(1/4-20x.25 LW)RAM | 103 |
| 2 | 2 | 2 | - | A | | 21017-2 | SCR,DRIVE(#2x.19)ID PLATE | 102 |
| REF | REF | REF | - | A | | 6-23715-5 | SCR,PAN HD(6-32x1.50)FEED ADJ | 101 |
| 1 | 1 | 1 | - | B | | 461264-1 | PLATE, IDENTIFICATION | 100 |
| 2 | 2 | 2 | - | A | | 3-21002-0 | SCR,BHC(10-32x.88)DRAG | 99 |
| 1 | 1 | 1 | - | A | | 22733-8 | SCR,BHC(8-32x.38 LW)ANVIL | 98 |
| REF | REF | REF | - | A | | 2-21002-9 | SCR,BHC(10-32x.75)CAP | 97 |
| REF | REF | REF | - | A | | 2-22733-8 | SCR,BHC(1/4-20x.62)HOUSING | 96 |
| REF | REF | REF | - | A | | 2-21002-7 | SCR,BHC(10-32x.50)SG ADJ BLOCK | 95 |
| 6 | 6 | 6 | - | A | | 2-21002-2 | SCR,BHC(8-32x.50)TERM H DWN | 94 |
| | | | | | | | | 93 |
| | | | | | | | | 92 |
| 1 | 1 | 1 | - | A | | 1-21002-7 | SCR,BHC(6-32x.38)CAM | 91 |
| | | | | | | | | 90 |
| 1 | 1 | - | - | A | | 7-21000-9 | SCR,SHC(4-40x.19)STRIPPER | 89 |
| | | | | | | | | 88 |
| 2 | 2 | 2 | - | A | | 2-21000-7 | SCR,SHC(8-32x.48)DEP-HOLD | 87 |
| 1 | 1 | 1 | - | A | | 2-22603-0 | SCR,HEX HD(8-32x.31)FEED FINGER | 86 |
| 2 | 2 | 2 | - | A | | 1-21000-3 | SCR,SHC(4-40x.25)F ST GUIDE | 85 |
| 1 | 1 | 1 | - | A | | 2-21000-7 | SCR,SHC(8-32x.50)STRIPPER | 84 |
| REF | REF | REF | - | A | | 3-21000-7 | SCR,SHC(10-32x.75)FEED ROD GD | 83 |
| REF | REF | REF | - | A | | 3-21000-6 | SCR,SHC(10-32x.62)FD ADJ BLK | 82 |
| 1 | 1 | 1 | - | A | | 3-21000-4 | SCR,SHC(10-32x.38)SG ADJ BL | 81 |
| REF | REF | REF | - | A | | 3-21000-4 | SCR,SHC(10-32x.38)PIVOT BLK | 80 |
| - | REF | - | - | B | | 455749-1 | GUARD, WINDOW | 79 |
| REF | - | - | - | B | | 679532-1 | INSERT, GUARD | 78 |
| | | | | | | | | 77 |
| | | | | | | | | 76 |
| | | | | | | | | 75 |
| 1 | 1 | 1 | - | A | | 690603-1 | SPRING, ASSIST | 74 |
| 1 | 1 | 1 | - | A | | 23030-1 | SCR,SHC(6-32x.25 SL)INS DISC | 73 |
| REF | REF | REF | - | A | | 458109-1 | WASHER, SPECIAL | 72 |
| REF | REF | REF | - | A | | 690517-1 | SPACER | 71 |
| -3 | -2 | -1 | U/M | DWG SIZE | | PART NO | DESCRIPTION | ITEM NO |

| QTY | REF | REF | REF | U/M | DWG SIZE | PART NO | DESCRIPTION | ITEM NO |
|-----|-----|-----|-----|-----|----------|----------|------------------------------|---------|
| | | | | | | | | 77 |
| | | | | | | | | 76 |
| | | | | | | | | 75 |
| 1 | 1 | 1 | - | A | | 690603-1 | SPRING, ASSIST | 74 |
| 1 | 1 | 1 | - | A | | 23030-1 | SCR,SHC(6-32x.25 SL)INS DISC | 73 |
| REF | REF | REF | - | A | | 458109-1 | WASHER, SPECIAL | 72 |
| REF | REF | REF | - | A | | 690517-1 | SPACER | 71 |

THIS DRAWING IS A CONTROLLED DOCUMENT FOR AMP INCORPORATED. IT IS SUBJECT TO CHANGE AND THE CONTROLLING ENGINEERING ORGANIZATION SHOULD BE CONTACTED FOR THE LATEST REVISION.

THIS INFORMATION IS CONFIDENTIAL AND IS DISCLOSED TO YOU ON CONDITION THAT NO FURTHER DISCLOSURE IS MADE BY YOU TO OTHER THAN AMP PERSONNEL WITHOUT WRITTEN AUTHORIZATION FROM AMP INCORPORATED, HARRISBURG, PA.