

TOP VIEW

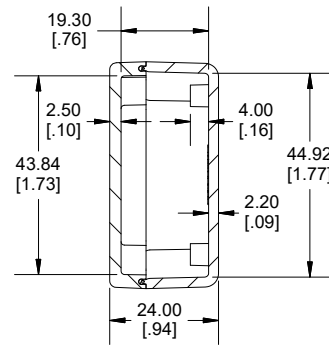

SECTION A-A  
END VIEW

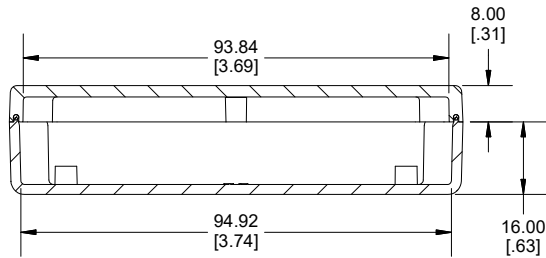
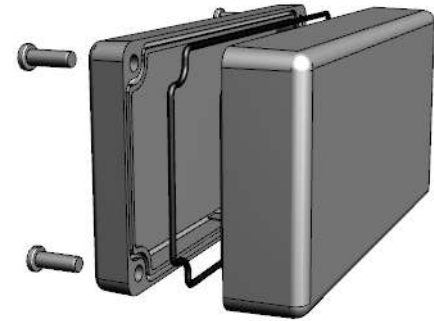

SECTION B-B  
SIDE VIEW

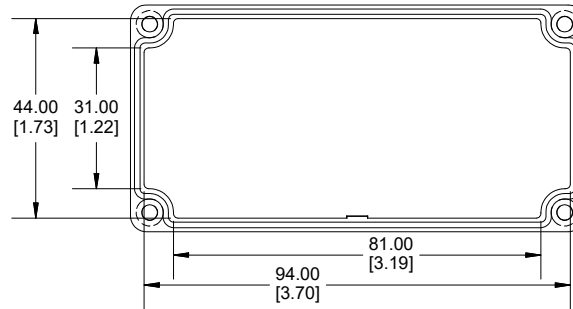

INSIDE LID

Enclosures can be Factory Modified (Milling, Drilling, Printing etc.)  
 Contact Factory ([modshop@hammfg.com](mailto:modshop@hammfg.com)) for quotes  
 Solid models of this enclosure available in .stp or .x\_t  
 (Part number and text placement/orientation on our products are subject to change,  
 we do not recommend using them as a locating reference for modification purposes)

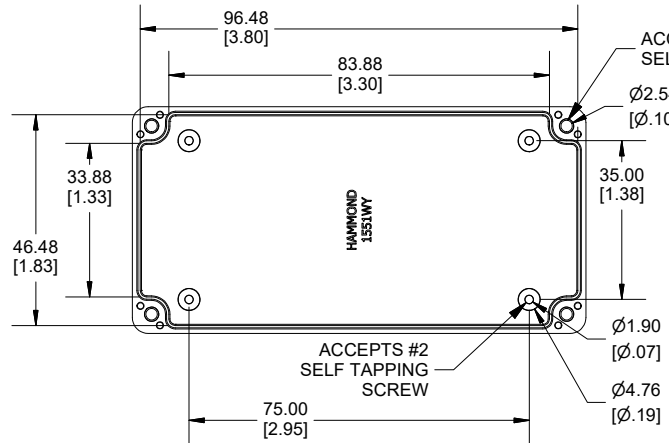

BOTTOM VIEW

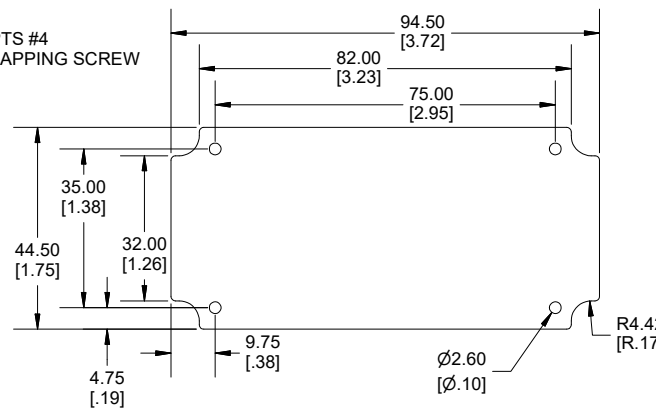

MAXIMUM  
P. C. BOARD

Dimensions:  
mm  
[inches]

NOTE	
Purchased assembly includes box, lid, gasket, 4 cover screws. Polycarbonate material is rated UL94 - V0	
<b>Recommended Torque : #4 Cover screw (71-100) Ozf.in / (50-70) cN.m</b>	
<b>Recommended Torque : #2 Internal screws (21-28) Ozf.in / (15-20) cN.m</b>	
PART NUMBERS	
1551WY Enclosure	
Polycarbonate Black Enclosure	1551WYBK
Polycarbonate Gray Enclosure	1551WYGY
ACCESSORIES	
Internal Mounting Post Screw [#2 x 3/16" Plastite Self-tapping (4.8mm)]	1553WTS100 (Pkg 100)
Stainless Steel Cover Screws [#4 X 3/8" Plastite Self-tapping (9.5mm)]	SC509-50 (Pkg 50)

**HAMMOND  
MANUFACTURING®**  
1551WY  
[www.hammondmfg.com](http://www.hammondmfg.com)