

- NOTES:
- 1) MATERIAL:
HOUSING - HIGH TEMPERATURE NYLON, UL94, V-0, BLACK
TERMINALS - COPPER ALLOY
ESD METAL TERMINAL - COPPER ALLOY
 - 2) PLATING:
TERMINALS:
0.76 MICRON MIN. SELECT GOLD AND
2.54 MICRON MIN. SELECT TIN/LEAD OVER
1.27 MICRON MIN. NICKEL OVERALL

ESD TERMINALS:
3.81 MICRON MIN. TIN/LEAD OVER
1.27 MICRON MIN. NICKEL OVERALL
 - 3) CONFORMS TO PRODUCT SPECIFICATION PS-73826-0000.
 - 4) CIRCUIT NUMBERS 1, 36 THRU 43, 45, 46, AND 75 THRU 80, ARE ADVANCED TERMINALS FOR SEQUENTIAL MATING.
 - 5) CONNECTOR WILL ACCEPT MATING TO A P.C. BOARD WITH A THICKNESS OF 1.57 ± 0.08 mm.
 - 6) PACKAGE IN TRAYS PER PK-70873-5025.
 - 7) ALL DIMENSION'S SYMETRICAL ABOUT CENTERLINE.

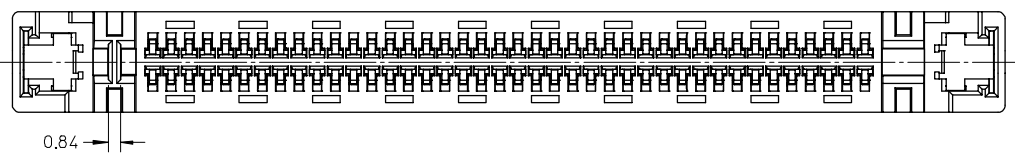

EC NO: UCP2003-0386 DRWN:KSTILES 2003/01/21 CHKD: 2003/01/23 APPR:MBANAKIS 2003/01/29	QUALITY SYMBOLS ▽ = 0 ▽ = 0	GENERAL TOLERANCES (UNLESS SPECIFIED)		SCALE 3:1	DESIGN UNITS METRIC	THIRD ANGLE PROJECTION	REVISE ON CAD ONLY
		4 PLACES ± --- ± --- 3 PLACES ± --- ± --- 2 PLACES ± 0.13 ± --- 1 PLACE ± 0.25 ± ---	DIMENSION STYLE MM ONLY	TITLE 80 CKT STRADDLEMOUNT SCA2 SALES DRAWING			
		ANGULAR ± 1/2° DRAFT WHERE APPLICABLE MUST REMAIN WITHIN DIMENSIONS	DRAWN BY DATE KSTILES 01/14/2002 CHECKED BY DATE MBANAKIS 01/16/2002 APPROVED BY DATE MBANAKIS 01/18/2002	MATERIAL NO. 750830080	DOCUMENT NO. SD-75083-001		
		SHEET NO. 1 OF 2		THIS DRAWING CONTAINS INFORMATION THAT IS PROPRIETARY TO MOLEX INCORPORATED AND SHOULD NOT BE USED WITHOUT WRITTEN PERMISSION			

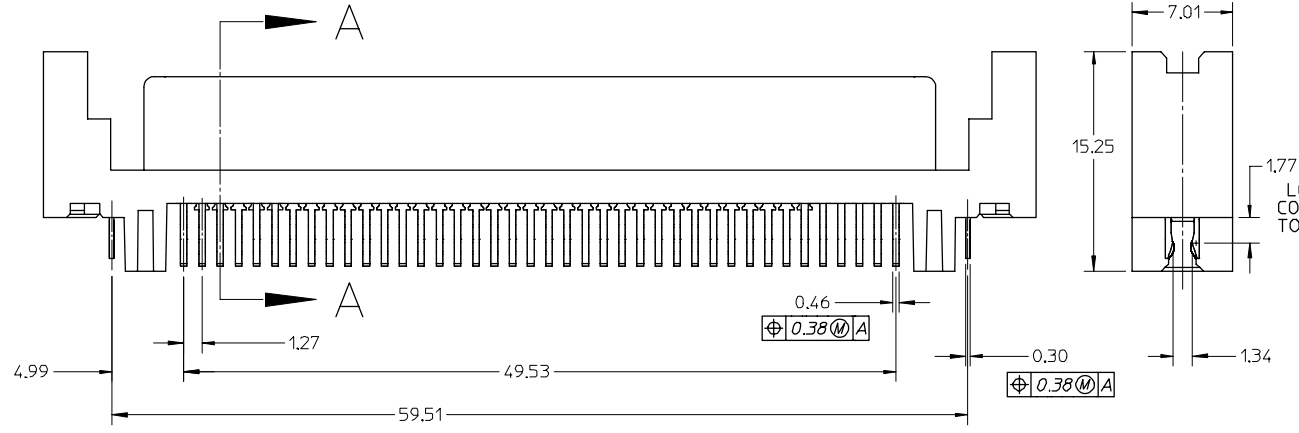
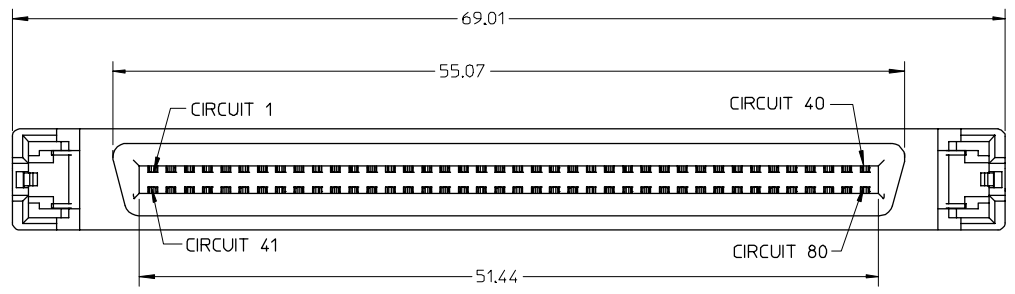
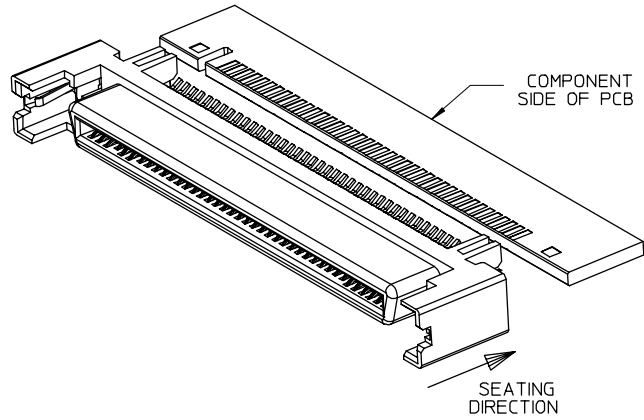

RECOMMENDED PCB LAYOUT (COMPONENT SIDE SHOWN)
RECOMMENDED PCB THICKNESS: 1.57mm

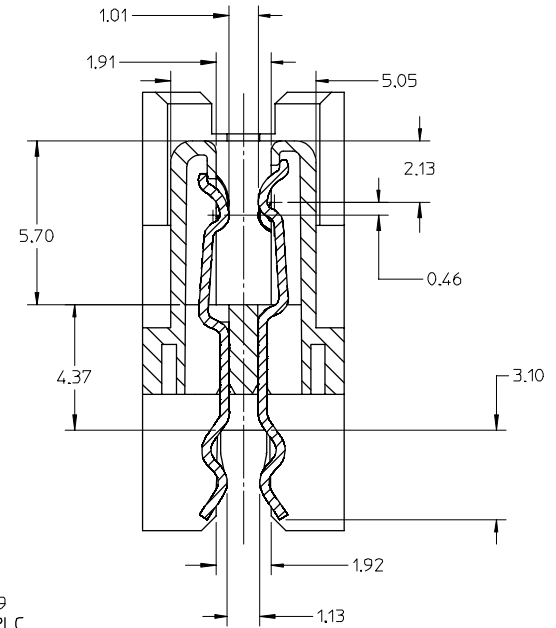
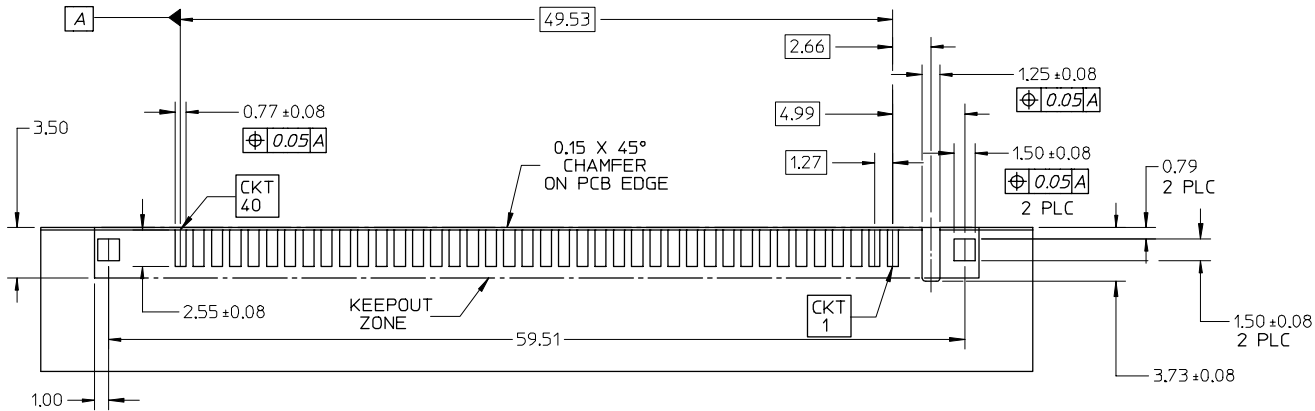

EC NO: UCP2003-0386 DRAWN: KSTILES 2003/01/21 CHKD: 2003/01/23 APPR: MBANAKIS 2003/01/29	QUALITY SYMBOLS ▽ = 0 ∇ = 0	GENERAL TOLERANCES (UNLESS SPECIFIED)		SCALE 3:1	DESIGN UNITS METRIC	THIRD ANGLE PROJECTION	REVISE ON CAD ONLY
		4 PLACES ± --- ± ---	3 PLACES ± --- ± ---	2 PLACES ± 0.13 ± ---	1 PLACE ± 0.25 ± ---	DIMENSION STYLE MM ONLY	TITLE 80 CKT STRADDLEMOUNT SCA2 SALES DRAWING
REV	DESCRIPTION	ANGULAR ± 1/2°		DRAFT WHERE APPLICABLE	MATERIAL NO.	DOCUMENT NO.	SHEET NO.
		MUST REMAIN WITHIN DIMENSIONS		APPROVED BY MBANAKIS	DATE 01/16/2002	750830080	SD-75083-001
				THIS DRAWING CONTAINS INFORMATION THAT IS PROPRIETARY TO MOLEX INCORPORATED AND SHOULD NOT BE USED WITHOUT WRITTEN PERMISSION			