

Sales Outline Drawing

| Specifications: | MILITARY UNIT |
|-----------------------|--|
| Sound Level Category | Medium |
| Mode of Operation | Fast Warble @ 2 - 10 PPS |
| Voltage Rating | 6 to 28 VDC |
| Frequency | 2900 ± 500 Hz |
| Loudness @ 2 FT | 80 to 91 dB(A) Typ. |
| Loudness @ Min Vdc | 70 dB(A) @ 2 Feet and 6 Vdc |
| Loudness @ Max Vdc | 85 dB(A) @ 2 Feet and 28 Vdc |
| Current Draw | 4-16mA |
| Duty Cycle (%) | 50 |
| Housing Material | 6/6 Nylon, Color: Black |
| Storage Temperature | -65° to +85° C |
| Operating Temperature | -40° to +85° C |
| Panel Mounting | Recommended hole size is 1.25"(31.75mm). Thread front will fit standard 30mm(1.181") hole. |
| Knurled Nut | Used to attach part to panel. The max recommended torque is 10 in-lbs. |
| Weight (Typical) | 1.6 oz (45g) |
| NEMA 3R,4X, & 12 | Approved with use of ACC03. |
| Options | Please contact factory. |

Dimensions: Inches (mm)

PART DIMENSIONS BEFORE CODE DATE 1521 5

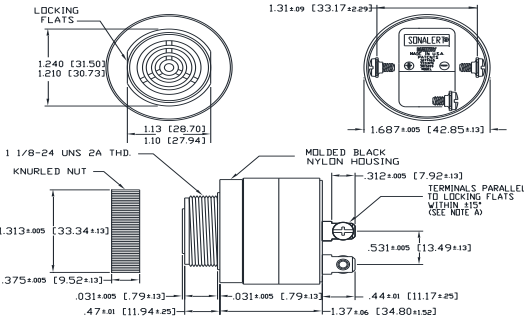

NOTE A: TERMINALS-032 BRASS TIN PLATED, TAPPED FOR #6-32 SCREW. TWO #6-32 NICKEL PLATED BRASS SCREWS INCLUDED WILL ACCEPT 1/4" QUICK CONNECT.
 NOTE B: MOUNTING- REMOVE BLACK PLASTIC NUT AND INSERT THREADED FRONT THROUGH 1.25" HOLE PUNCHED IN PANEL. IF ORIENTATION IS NEEDED, NOTE LOCKING FLATS ON DRAWING. SCREW NUT BACK ON. DO NOT OVERTIGHTEN.

PART DIMENSIONS AFTER CODE DATE 1522 1

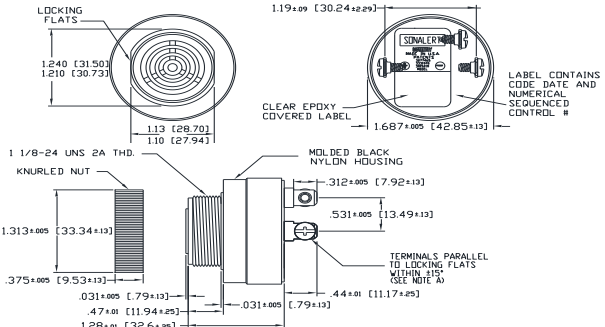

NOTE A: TERMINALS-032 BRASS TIN PLATED, TAPPED FOR #6-32 SCREW. TWO #6-32 NICKEL PLATED BRASS SCREWS INCLUDED WILL ACCEPT 1/4" QUICK CONNECT.
 NOTE B: MOUNTING- REMOVE BLACK PLASTIC NUT AND INSERT THREADED FRONT THROUGH 1.25" HOLE PUNCHED IN PANEL. IF ORIENTATION IS NEEDED, NOTE LOCKING FLATS ON DRAWING. SCREW NUT BACK ON. DO NOT OVERTIGHTEN.

PRODUCES TWO TONES ALTERNATELY WHEN USED WITH ADDITIONAL CONTINUOUS UNIT AS SHOWN.

