

20-Output DB2000Q Buffer with Ultra Low Additive Jitter

Features

- Fully Compliant with Intel DB2000Q Specification
- 20 Low-Power Push-Pull HCSL PCIe Outputs
- Ultra-low additive jitter: 20fs maximum
- Supports clock frequencies from 0 to 250MHz
- Supports 3.3V power supplies
- Embedded Low Drop Out (LDO) Voltage regulator provides superior Power Supply Noise Rejection
- Maximum output to output skew of 50ps
- SMBus Interface
- Eight OE pins
- Embedded series terminations adjusted for 85Ω differential transmission line
- Transparent for Spread-Spectrum Clock

Ordering Information

ZL40292LDG1	72 pin QFN	Trays
ZL40292LDF1	72 pin QFN	Tape and Reel
Package size: 10 x 10 mm		
-40°C to +85°C		

Applications

- PCI Express generation 1/2/3/4/5 clock distribution
- Intel QPI
- Servers
- Storage and Data Centers
- Switches and Routers

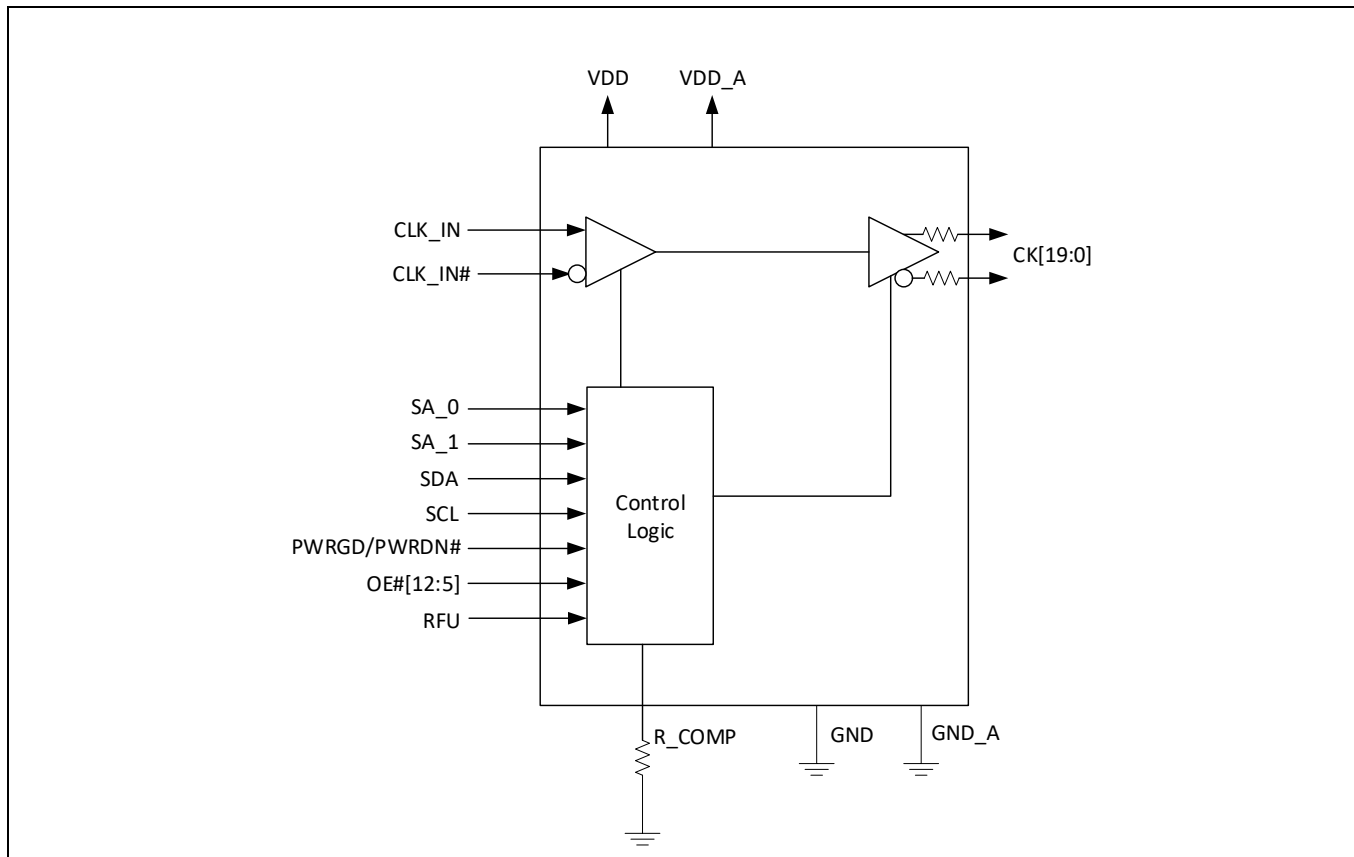

Figure 1. Functional Block Diagram

Table of Contents

Features.....	1
Applications.....	1
Table of Contents	2
Pin Diagram	5
Pin Descriptions.....	6
Functional Description	8
Clock Inputs	8
Clock Outputs	9
Termination of unused outputs	10
Power Supply Filtering.....	10
OE# and Output Enables (Control Register)	10
OE# Assertion (Transition from '1' to '0').....	10
OE# De-Assertion (Transition from '0' to '1').....	11
PWRGD / PWRDN#	11
PWRDN# Assertion	11
PWRGD Assertion.....	11
Programming via SMBus	13
SMBus Byte Read/Write	13
SMBus Block Read/Write	14
Register Map	16
AC and DC Electrical Characteristics	19
Absolute Maximum Ratings	19
DC Electrical Specification.....	20
AC Electrical Specification.....	22
SMBus Electrical Characteristics.....	25
Package Outline	27

List of Figures

Figure 1.	Functional Block Diagram.....	1
Figure 2.	Pin Diagram	5
Figure 3.	Input driven by a push-pull differential output.....	8
Figure 4.	Input driven by an HCSL output	9
Figure 5.	Input driven by a single ended output	9
Figure 6.	Terminating differential outputs.	9
Figure 7.	Power Supply Filtering	10
Figure 8.	PWRDN# Assertion	11
Figure 9.	PWRGD and V_{DD} Relationship diagram.....	12
Figure 10.	PWRGD# Assertion	12
Figure 11.	SMBus Byte Read.....	13
Figure 12.	SMBus Byte Write	14
Figure 13.	SMBus Block Read	14
Figure 14.	SMBus Block Write.....	15
Figure 15.	DC Test Load (as per DB2000Q Specification).....	20
Figure 16.	Single-Ended Measurement Points for T_{Rise} and T_{Fall}	21
Figure 17.	Single-Ended Measurement Points for V_{ovs} , V_{uds} , V_{rb}	21
Figure 18.	Differential (CK, CK#) Measurement Points	21
Figure 19.	AC Test Load as per DB2000Q Specification	22
Figure 20.	SMBus Timing	25

List of Tables

Table 1 Pin Descriptions	6
Table 2 OE Functionality.....	10
Table 3 PWRGD / PWRDN# Functionality.....	11
Table 4 SMBus Address Table.....	13
Table 5 Byte 0: Output Enable.....	16
Table 6 Byte 1: Output Enable Control Register	16
Table 7 Byte 2: Output Enable Control Register	16
Table 8 Byte 3: OE# Pin Realtime Readback Control Register	17
Table 9 Byte 4: Reserved Control Register.....	17
Table 10 Byte 5: Vendor/Revision Identification Control Register.....	17
Table 11 Byte 6: Device ID Control Register	18
Table 12 Byte 7: Byte Count Register	18
Table 13 Absolute Maximum Ratings*.....	19
Table 14 DC Operating Characteristics*.....	20
Table 15 Differential DC Output Characteristics*.....	20
Table 16 Power Noise Tolerance*	22
Table 17 Skew and Jitter.....	22
Table 18 Differential Output Clock AC Characteristics	24
Table 19 Differential Input Clock AC Characteristics	24
Table 20 Current Consumption.....	24
Table 21 SMBus Electrical Characteristics.....	25
Table 22 10x10mm QFN Package Thermal Properties	26

Pin Diagram

The device is packaged in a 10x10mm 72-pin QFN.

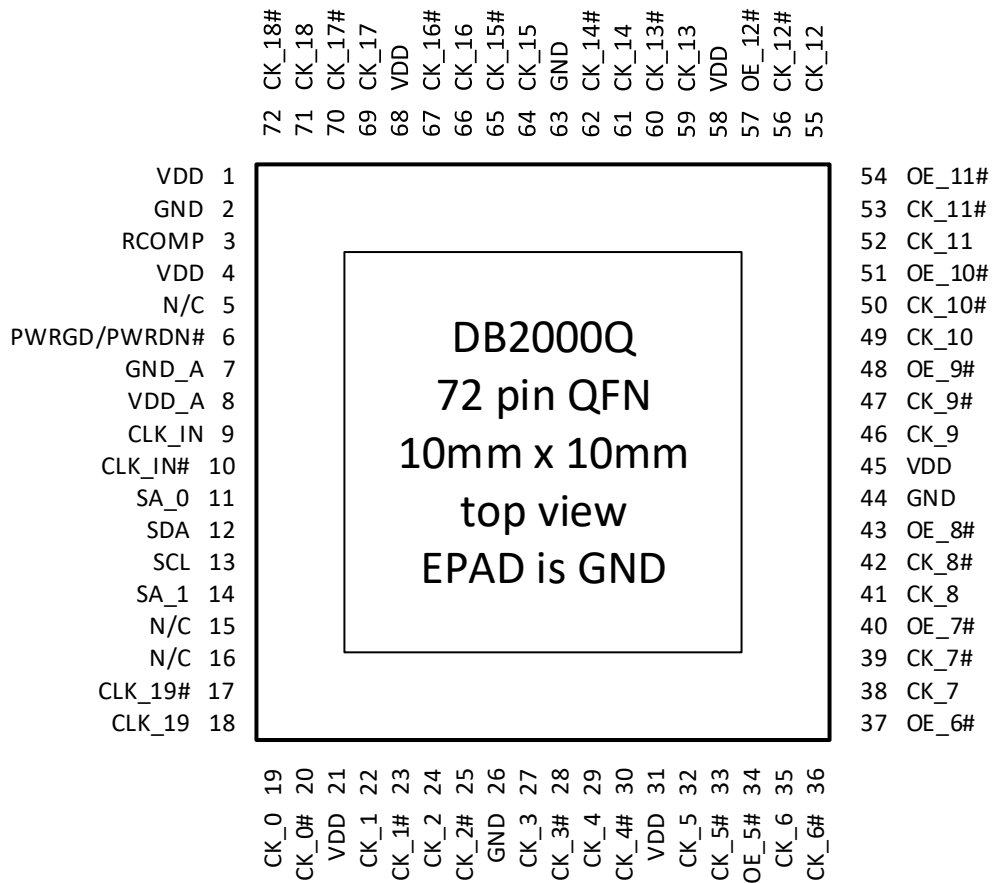

Figure 2. Pin Diagram

Pin Descriptions

The I/O column uses the following symbols: I – input, I_{PU} – input with 120kΩ internal pull-up resistor, I_{PD} – input with 300kΩ internal pull-down resistor, O – output, I/O – Input/Output Drain pin, NC-No connect pin, P – power supply pin, . I_{TRI} – Tri-level input pin biased to VDD/2 by internal 120kΩ pull-up and 120kΩ pull-down resistor.

Table 1 Pin Descriptions

#	Name	I/O	Description
Input Reference			
9 10	CLK_IN CLK_IN#	I	Input Differential or Single Ended Reference Input frequency range 0Hz to 250MHz.
Output Clocks			
19 20 22 23 24 25 27 28 29 30 32 33 35 36 38 39 41 42 46 47 49 50 52 53 55 56 59 60 61 62 64 65	CK_0 CK_0# CK_1 CK_1# CK_2 CK_2# CK_3 CK_3# CK_4 CK_4# CK_5 CK_5# CK_6 CK_6# CK_7 CK_7# CK_8 CK_8# CK_9 CK_9# CK_10 CK_10# CK_11 CK_11# CK_12 CK_12# CK_13 CK_13# CK_14 CK_14# CK_15 CK_15#	O	Ultra-Low Additive Jitter Differential Outputs 0 to 19 Output frequency range 0 to 250MHz

66	CK_16								
67	CK_16#								
69	CK_17								
70	CK_17#								
71	CK_18								
72	CK_18#								
17	CK_19#								
18	CK_19								
Hardware Control									
34	OE_5#	I _{PD}	Output Enable. Logic level on these pins enables/disables the corresponding output. <table border="1" data-bbox="618 638 1474 779"> <thead> <tr> <th>OE_n#</th> <th>CK_n/n#</th> </tr> </thead> <tbody> <tr> <td>0</td> <td>Active</td> </tr> <tr> <td>1</td> <td>Low/Low both pulled low by 42.5 Ω resistor</td> </tr> </tbody> </table>	OE_n#	CK_n/n#	0	Active	1	Low/Low both pulled low by 42.5 Ω resistor
OE_n#	CK_n/n#								
0	Active								
1	Low/Low both pulled low by 42.5 Ω resistor								
37	OE_6#								
40	OE_7#								
43	OE_8#								
48	OE_9#								
51	OE_10#								
54	OE_11#								
57	OE_12#								
6	PWRGD/PWRDN#	I	Power up / power down						
3	R_COMP	I	Not used						
SMBus Control									
13	SCL	I	SMBus slave clock input						
12	SDA	I/O	Input/Open drain SMBus data						
11	SA_0	I _{TRI}	Tri level address selection inputs						
14	SA_1								
Power and Ground									
1	VDD	P	Positive Supply Voltage. Connect to 3.3V supply.						
4									
21									
31									
45									
58									
68									
8	VDD_A	P	Positive Analog Supply Voltage Connect 3.3V power supply.						
2	GND	P	Ground Connect to ground						
26									
44									
63									
7	GND_A	P	Analog Ground. Connect to ground						

E-Pad	GND	P	Ground. Connect to ground
No Connect Pins			
5 15 16	N/C		No Connect. These pins are not connected to the die. Leave them open. One of these pins might be used for future modifications of DB2000Q spec. The current DB2000Q v1.0 standard calls for RFU (Reserved for Future Upgrades) pin but does not assign it to any pin number.

Functional Description

The ZL40292 is an ultra-low additive jitter, low power 1 to 20 fanout buffer which is fully compliant with Intel DB2000Q Standard.

The device operates from 3.3V+/-5% supply as per Intel spec. Its operation is guaranteed over the industrial temperature range -40°C to +85°C.

Clock Inputs

The following blocks diagram shows how to terminate different signals fed to the ZL40292 inputs.

The device input can be fed with transmission lines of any impedance. Examples below show only 50Ω single ended, 85 Ω differential and 100 Ω differential which are the most common ones in practice. Figure 3 and Figure 4 show how to terminate the input when driven from a push-pull and traditional HCSL drivers respectively.

Figure 5 shows how to terminate a single ended output such as LVCMOS. This example assumes 50 Ω transmission line which is the most common for single ended CMOS signaling. Resistors R1 and R2 are chosen to provide 50 Ω termination and proper biasing and $R_o + R_s$ ideally should be 50 Ω so that the transmission line is terminated at both ends with its characteristic impedance. If the driving strength of the output driver is not sufficient to drive low impedance, the value of series resistor R_s should be increased. This will reduce the voltage swing at the input but this should be fine as long as the input voltage swing requirement is not violated (Figure 5). The source resistors of $R_s = 270\Omega$ could be used for standard LVCMOS driver. This will provide 516mV of voltage swing for 3.3V LVCMOS driver with load current of $(3.3V/2) * (1/(270\Omega + 50\Omega)) = 5.16mA$.

For optimum performance both differential input pins ($_p$ and $_n$) need to be DC biased to the same voltage. Hence, the ratio $R1/R2$ should be equal to the ratio $R3/R4$.

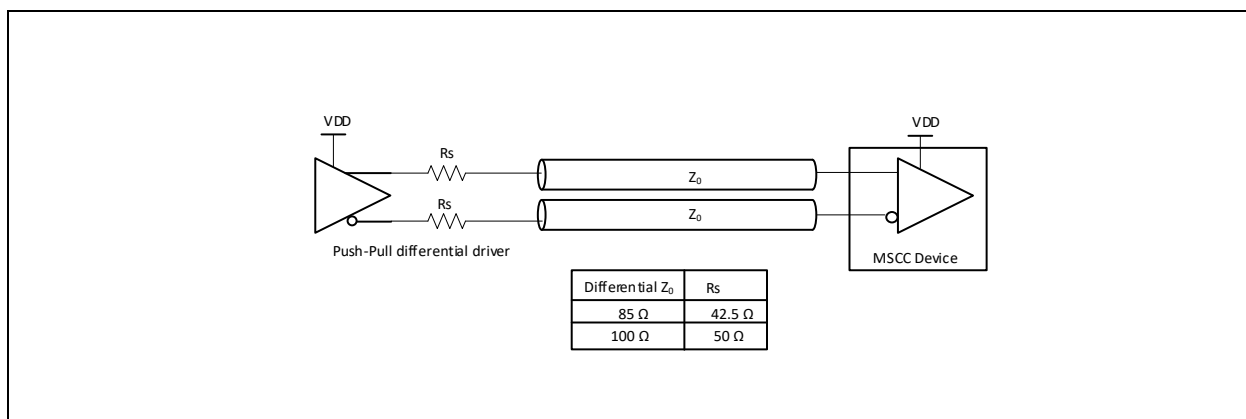

Figure 3. Input driven by a push-pull differential output

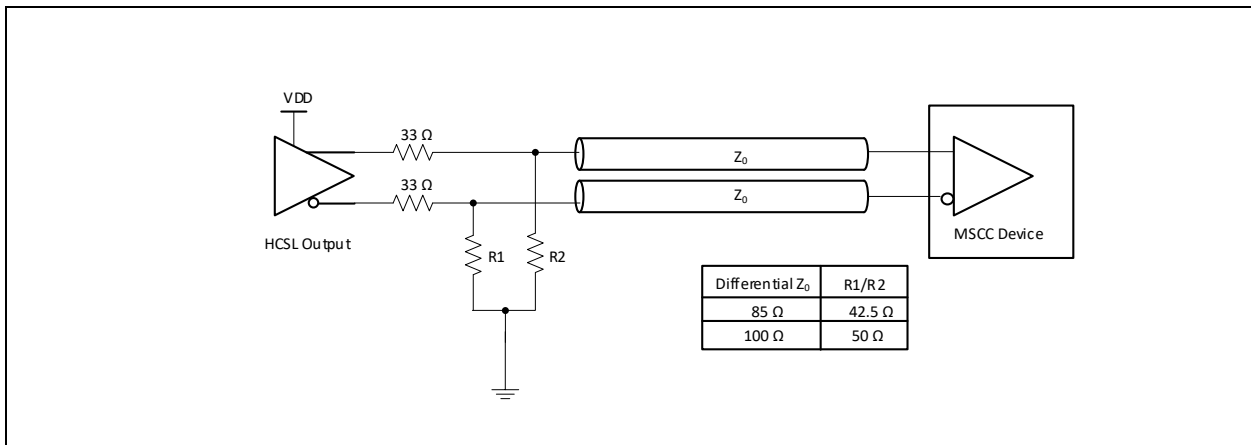

Figure 4. Input driven by an HCSL output

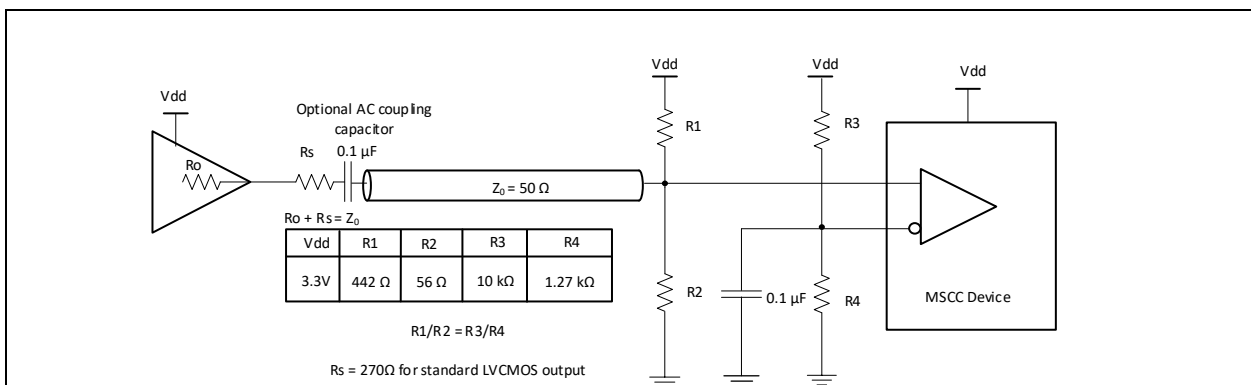

Figure 5. Input driven by a single ended output

Clock Outputs

Differential outputs have embedded termination resistors as shown in Figure 6. This provides significant saving relative to traditional current based HCSL outputs which require four resistors per differential pair (80 resistors for 20 outputs).

Embedded series termination resistors are matched for 85 Ω differential transmission line.

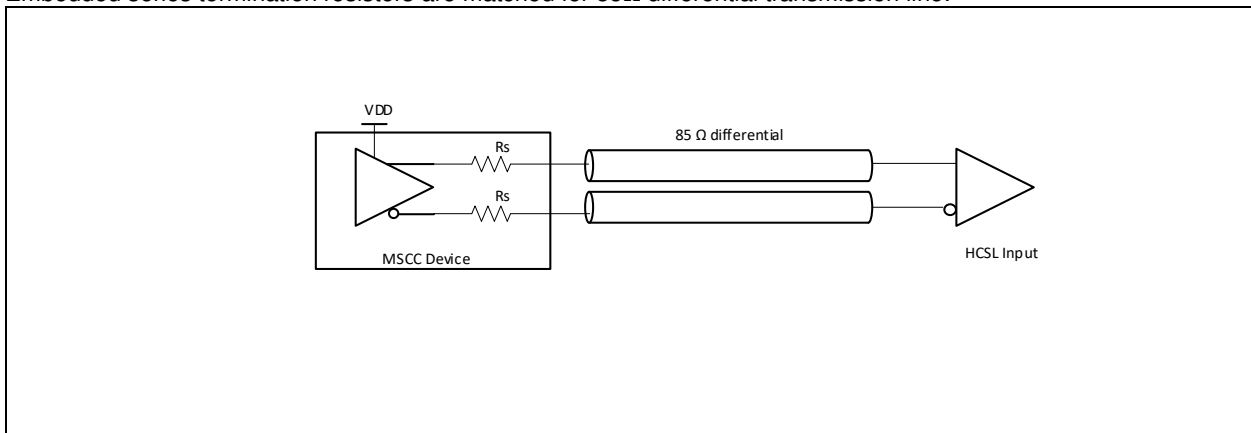

Figure 6. Terminating differential outputs.

Termination of unused outputs

Unused outputs should be left unconnected.

Power Supply Filtering

Each power pin (VDDA and VDD) should be decoupled with 0.1 μ F capacitor with minimum equivalent series resistance (ESR) and minimum series inductance (ESL). For example, 0402 X5R Ceramic Capacitors with 6.3V minimum rating could be used. These capacitors should be placed as close as possible to the power pins. To reduce the power noise from adjacent digital components on the board each power supply could be further insulated with low DC resistance ferrite bead with two capacitors. The ferrite bead will also insulate adjacent component from the noise generated from the device. Following figure shows recommended decoupling.

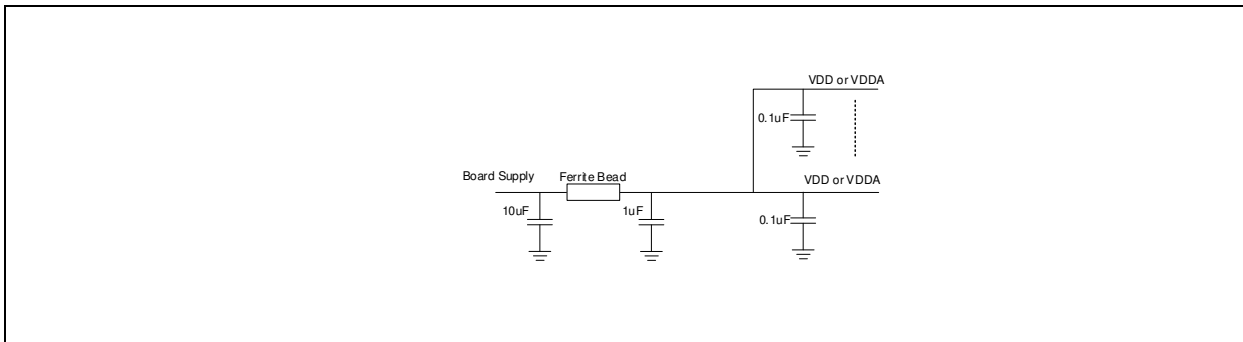

Figure 7. Power Supply Filtering

OE# and Output Enables (Control Register)

Each output can be individually enabled or disabled by SMBus control register bits or via OE# pin. The OE# pins are asynchronous asserted-low signals. The Output Enable bits in the SMBus registers are active high and are set to enable by default.

OE# pins are mapped to CK[12:5] outputs.

Note that the logic level for assertion or de-assertion is different in software than it is on hardware. This follows hardware default nomenclature for communication channels (e.g., output is enabled if OE# pin is pulled low) and still maintains software programming logic (e.g., output is enabled if OE register is true).

Refer to Table 2 for the truth table for enabling and disabling outputs via hardware and software. Note that both the control register bit must be a '1' AND the OE# pin must be a '0' for the output to be active.

Table 2 OE Functionality

Inputs		OE# Hardware Pins and Control Register Bits			
PWRGD/ PWRDN#	CK_IN/ CK_IN#	SMBUS Enable Bit	OE# Pin	CK/CK# [12:5]	CK/CK# [4:0] and [19:13]
0	X	X	X	0	0
1	Running	0	X	0	0
		1	0	Running	Running
		1	1	0	Running

OE# Assertion (Transition from '1' to '0')

All differential outputs that were disabled are to resume normal operation in a glitch free manner. The latency from the assertion to active outputs is 0 - 10 CK clock periods.

OE# De-Assertion (Transition from '0' to '1')

The impact of de-asserting OE# is each corresponding output will transition from normal operation to disabled in a glitch free manner. A minimum of four valid clocks will be provided after the de-assertion of OE#. The maximum latency from the de-assertion to disabled outputs is 10 CK clock periods.

PWRGD / PWRDN#

PWRGD is asserted high and de-asserted low. De-assertion of PWRGD (pulling the signal low) is equivalent to indicating a powerdown condition. PWRGD (assertion) is used by the ZL40292 to sample initial configurations such as SA selections.

After PWRGD has been asserted high for the first time, the pin becomes a PWRDN# (Power Down) pin which is used to disable (drive low/low) all clocks cleanly and instruct the device to invoke power savings mode. PWRDN# is a completely asynchronous active low input. When entering power savings mode, PWRDN# should be asserted low prior to shutting off the input clock or power to ensure all clocks shut down in a glitch free manner. When PWRDN# is de-asserted high, all clocks will start and stop without any abnormal behavior and will meet all AC and DC parameters.

The assertion and de-assertion of PWRDN# is asynchronous.

Disabling of the CK_IN input clock prior to assertion of PWRDN# is an undefined mode and not recommended. Operation in this mode may result in glitches.

Table 3 PWRGD / PWRDN# Functionality

PWRGD / PWRDN#	CK	CK#
0	LOW	LOW
1	Normal	Normal

PWRDN# Assertion

When PWRDN# is sampled low by two consecutive rising edges of CK#, all differential outputs will be disabled on the next CK# high to low transition.

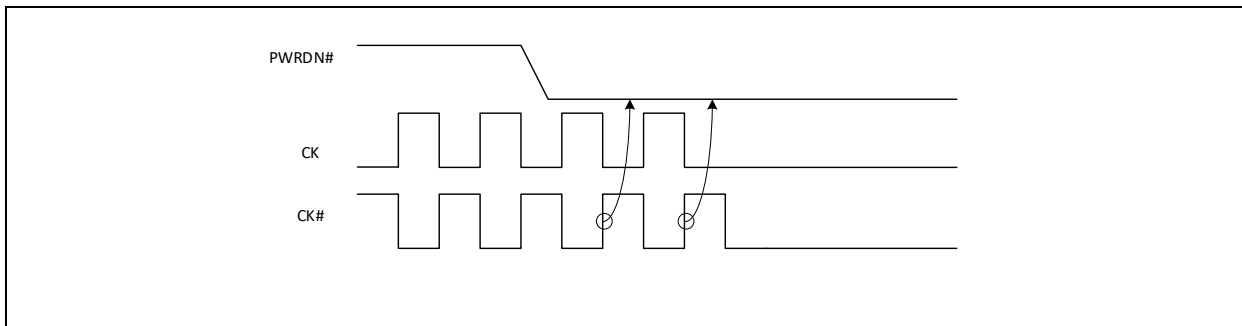

Figure 8. PWRDN# Assertion

PWRGD Assertion

PWRGD to the clock buffer should not be asserted before V_{DD} reaches V_{DDmin} . Prior to V_{DDmin} it is recommended to hold PWRGD low (less than 0.5 V)

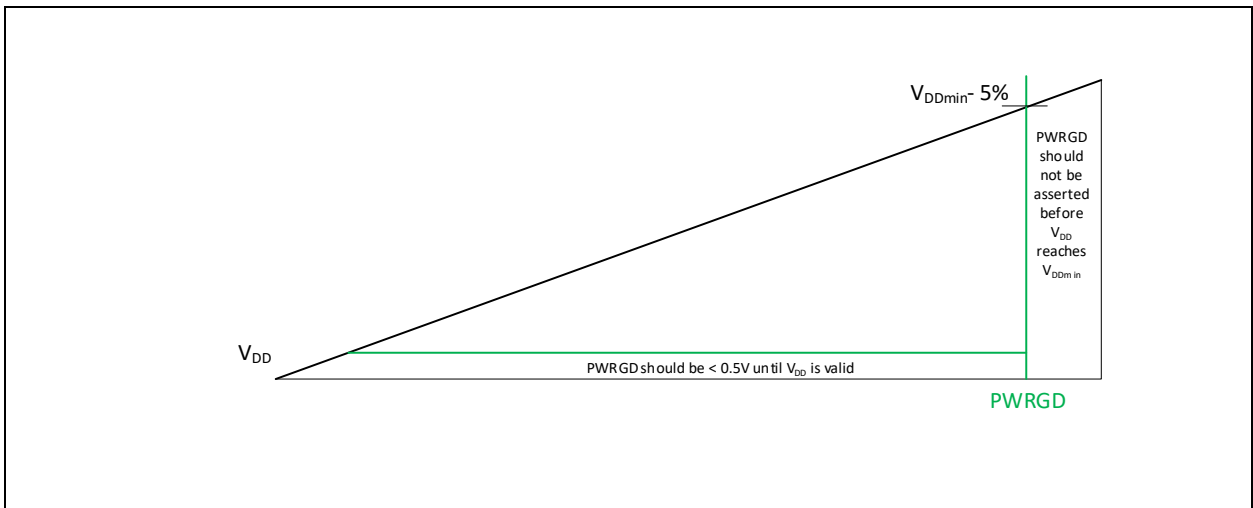

Figure 9. PWRGD and V_{DD} Relationship diagram

The power-up latency T_{stable} is to be less than 1.8 ms. This is the time from the valid CLK_IN input clocks and the assertion of the PWRGD signal to the time that stable clocks are output from the buffer chip. All differential outputs stopped in a disabled condition resulting from power down must be driven high in less than 300 μ s of PWRGD assertion to a voltage greater than 200 mV.

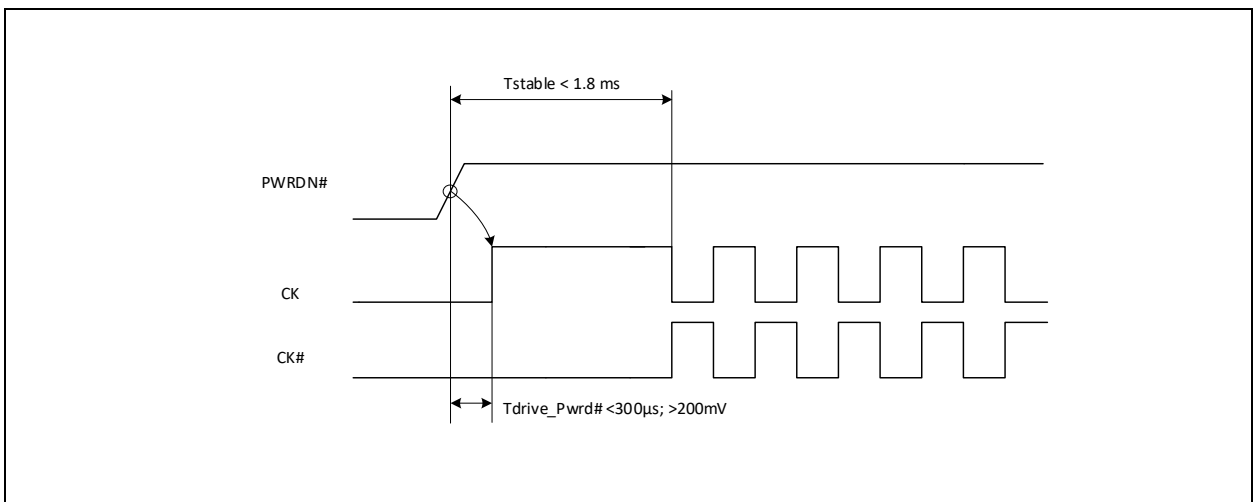

Figure 10. PWRGD Assertion

Programming via SMBus

The address selection is done via SA_0 and SA_1 tri-level hardware pins, which select the appropriate address for the device. The two tri-level input pins that can configure the ZL40292 to nine different addresses (refer to Table 14 for VIL_Tri, VIM_Tri, VIH_Tri signal level).

Table 4 SMBus Address Table

SA_1	SA_0	SMBus Address
L	L	D8
L	M	DA
L	H	DE
M	L	C2
M	M	C4
M	H	C6
H	L	CA
H	M	CC
H	H	CE

SMBus Byte Read/Write

Reading or writing a register in a SMBus slave device in byte mode always involves specifying the register number.

Read. The standard byte read is as shown in Figure 11. It is an extension of the byte write. The write start condition is repeated then the slave device starts sending data and the master acknowledges it until the last byte is sent. The master terminates the transfer with a NAK then a stop condition. For byte operation, the 2*7th bit of the command byte must be set. For block operations, the 2*7th bit must be reset. If the bit is not set, the next byte must be the byte transfer count.

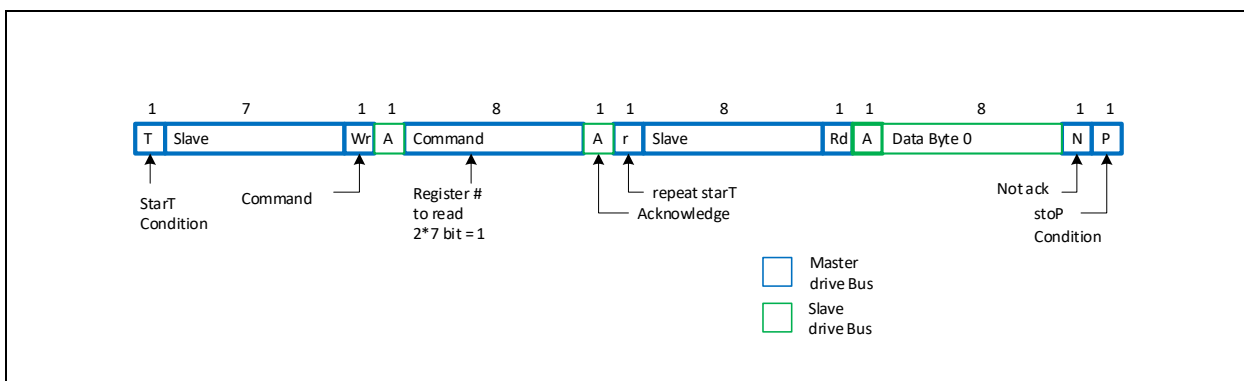

Figure 11. SMBus Byte Read

Write. Figure 12 illustrates a simple typical byte write. For byte operation the 2*7th bit of the command byte must be set. For block operations, the 2*7th bit must be reset. If the bit is not set the next byte must be the byte transfer count. The count can be between 1 and 32. It cannot be zero or exceed 32.

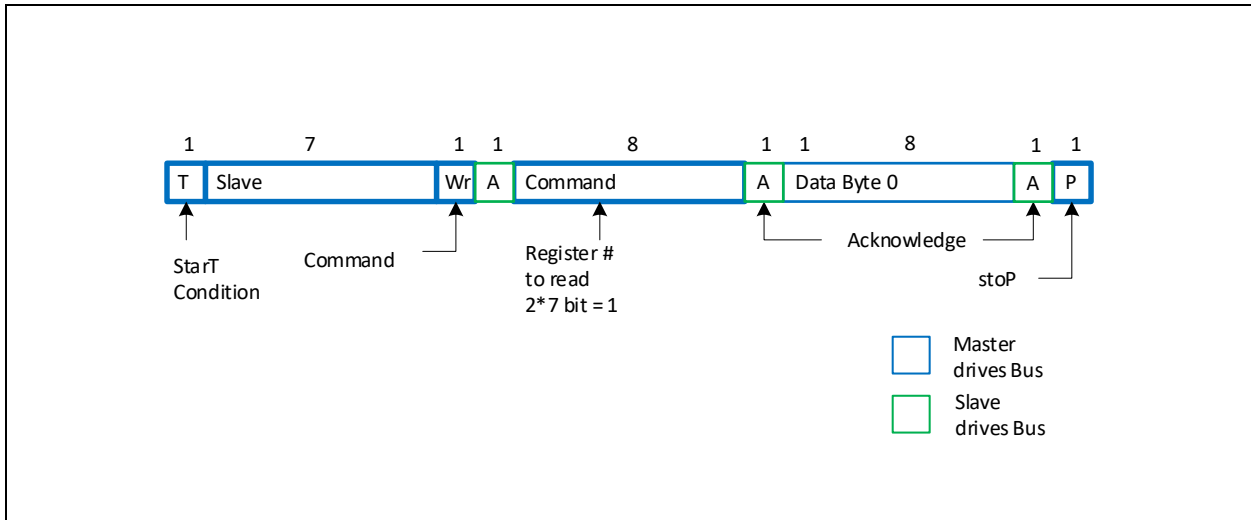

Figure 12. SMBus Byte Write

SMBus Block Read/Write

Read. After the slave address is sent with the r/w condition bit set, the command byte is sent with the MSB = 0. The slave Ack's the register index in the command byte. The master sends a repeat start function. After the slave Ack's this the slave sends the number of bytes it wants to transfer (>0 and <33). The master Ack's each byte except the last and sends a stop function.

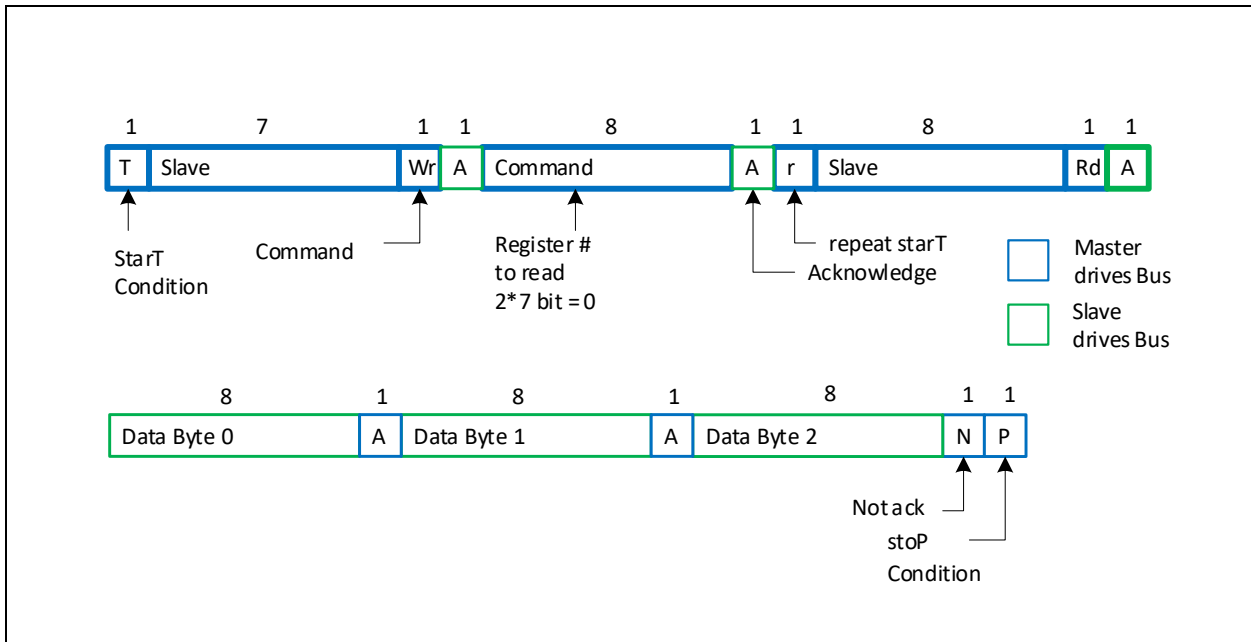

Figure 13. SMBus Block Read

Write. After the slave address is sent with the r/w condition bit not set, the command byte is sent with the MSB = 0. The lower seven bits indicate what register to start the transfer at. If the command byte is 00h, the slave device will be compatible with existing block mode slave devices. The next byte of a write must be the count of bytes that the master will transfer to the slave device. The byte count must be greater than zero and less than 33. Following this byte are the data bytes to be transferred to the slave device. The slave device always acknowledges each byte received. The transfer is terminated after the slave sends the Ack and the master sends a stop function.

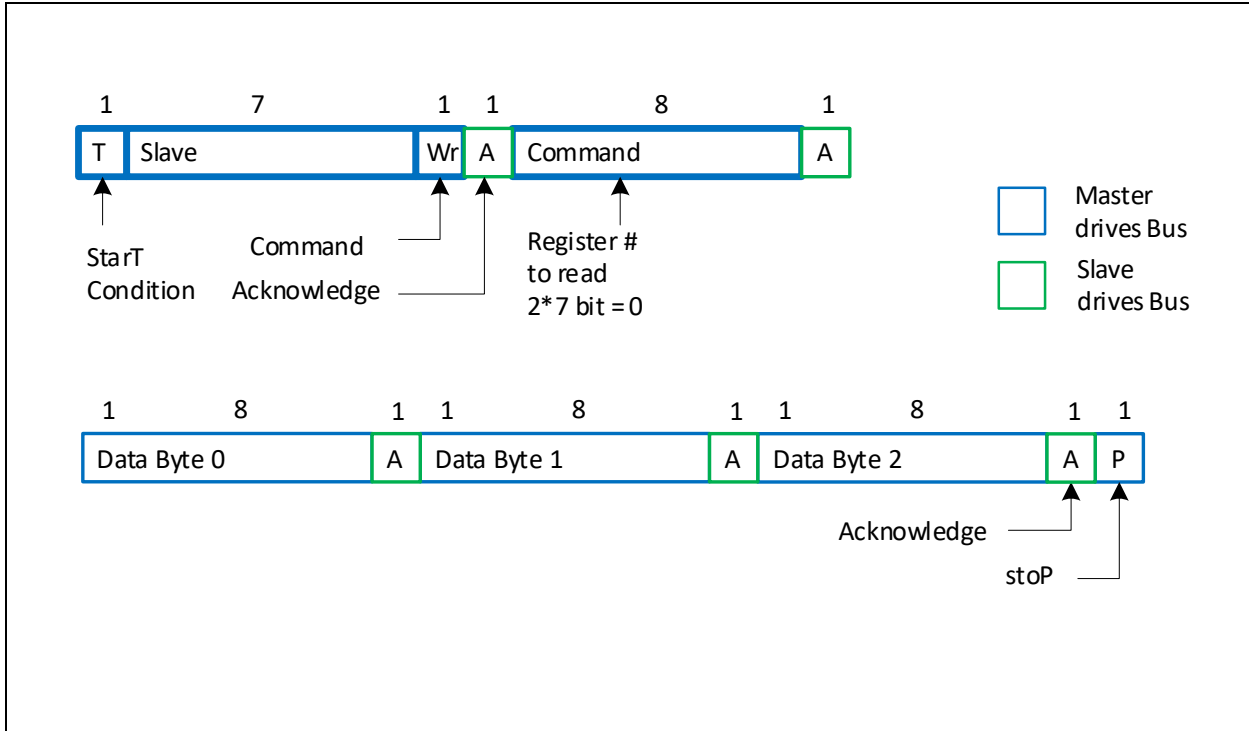

Figure 14. SMBus Block Write

Register Map

Table 5 Byte 0: Output Enable

Bit	Description	If Bit = 0	If Bit = 1	Type	Default	Output(s) Affected
0	Reserved				0	
1	Reserved				0	
2	Reserved				0	
3	Output Enable CK 16	LOW	Enable	RW	1	CK[16]
4	Output Enable CK 17	LOW	Enable	RW	1	CK[17]
5	Output Enable CK 18	LOW	Enable	RW	1	CK[18]
6	Output Enable CK 19	LOW	Enable	RW	1	CK[19]
7	Reserved				0	

Table 6 Byte 1: Output Enable Control Register

Bit	Description	If Bit = 0	If Bit = 1	Type	Default	Output(s) Affected
0	Output Enable CK 0	LOW	Enabled	RW	1	CK[0]
1	Output Enable CK 1	LOW	Enabled	RW	1	CK[1]
2	Output Enable CK 2	LOW	Enabled	RW	1	CK[2]
3	Output Enable CK 3	LOW	Enabled	RW	1	CK[3]
4	Output Enable CK 4	LOW	Enabled	RW	1	CK[4]
5	Output Enable CK 5	LOW	Enabled	RW	1	CK[5]
6	Output Enable CK 6	LOW	Enabled	RW	1	CK[6]
7	Output Enable CK 7	LOW	Enabled	RW	1	CK[7]

Table 7 Byte 2: Output Enable Control Register

Bit	Description	If Bit = 0	If Bit = 1	Type	Default	Output(s) Affected
0	Output Enable CK 8	LOW	Enabled	RW	1	CK[8]
1	Output Enable CK 9	LOW	Enabled	RW	1	CK[9]
2	Output Enable CK 10	LOW	Enabled	RW	1	CK[10]
3	Output Enable CK 11	LOW	Enabled	RW	1	CK[11]
4	Output Enable CK 12	LOW	Enabled	RW	1	CK[12]
5	Output Enable CK 13	LOW	Enabled	RW	1	CK[13]
6	Output Enable CK 14	LOW	Enabled	RW	1	CK[14]
7	Output Enable CK 15	LOW	Enabled	RW	1	CK[15]

Table 8 Byte 3: OE# Pin Realtime Readback Control Register

Bit	Description	If Bit = 0	If Bit = 1	Type	Default	Output(s) Affected
0	Realtime Readback of OE_5#	OE_5# Low	OE_5# High	R	Realtime	CK[5]
1	Realtime Readback of OE_6#	OE_6# Low	OE_6# High	R	Realtime	CK[6]
2	Realtime Readback of OE_7#	OE_7# Low	OE_7# High	R	Realtime	CK[7]
3	Realtime Readback of OE_8#	OE_8# Low	OE_8# High	R	Realtime	CK[8]
4	Realtime Readback of OE_9#	OE_9# Low	OE_9# High	R	Realtime	CK[9]
5	Realtime Readback of OE_10#	OE_10# Low	OE_10# High	R	Realtime	CK[10]
6	Realtime Readback of OE_11#	OE_11# Low	OE_11# High	R	Realtime	CK[11]
7	Realtime Readback of OE_12#	OE_12# Low	OE_12# High	R	Realtime	CK[12]

Table 9 Byte 4: Reserved Control Register

Bit	Description	If Bit = 0	If Bit = 1	Type	Default	Output(s) Affected
0	Reserved				0	
1	Reserved				0	
2	Reserved				0	
3	Reserved				0	
4	Reserved				0	
5	Reserved				0	
6	Reserved				0	
7	Reserved				0	

Table 10 Byte 5: Vendor/Revision Identification Control Register

Bit	Description	If Bit = 0	If Bit = 1	Type	Default	Output(s) Affected
0	Vendor ID Bit 0			R	1	
1	Vendor ID Bit 1			R	1	
2	Vendor ID Bit 2			R	0	
3	Vendor ID Bit 3			R	0	
4	Revision Code Bit 0			R	0	
5	Revision Code Bit 1			R	1	
6	Revision Code Bit 2			R	0	
7	Revision Code Bit 3			R	0	

Table 11 Byte 6: Device ID Control Register

Bit	Description	If Bit = 0	If Bit = 1	Type	Default	Output(s) Affected
0	Device ID 0			R	0	
1	Device ID 1			R	0	
2	Device ID 2			R	1	
3	Device ID 3			R	1	
4	Device ID 4			R	1	
5	Device ID 5			R	0	
6	Device ID 6			R	1	
7	Device ID 7 (MSB)			R	0	

Table 12 Byte 7: Byte Count Register

Bit	Description	If Bit = 0	If Bit = 1	Type	Default	Output(s) Affected
0	BC0 - Writing to this register configures how many bytes will be read back			RW	0	
1	BC1 - Writing to this register configures how many bytes will be read back			RW	0	
2	BC2 - Writing to this register configures how many bytes will be read back			RW	0	
3	BC2 - Writing to this register configures how many bytes will be read back			RW	1	
4	BC3 - Writing to this register configures how many bytes will be read back			RW	0	
5	BC4 - Writing to this register configures how many bytes will be read back			RW	0	
6	Reserved				0	
7	Reserved				0	

AC and DC Electrical Characteristics

Absolute Maximum Ratings

Table 13 Absolute Maximum Ratings*

	Parameter	Sym.	Min.	Max.	Units	Notes
1	3.3 V Core Supply Voltage	$V_{DD,A}$	-	4.6	V	3
2	3.3 V I/O Supply Voltage	V_{DD}	-	4.6	V	3
5	3.3 V Input High Voltage	V_{IH}	-	4.6	V	1, 3
	3.3 V Input Low Voltage	V_{IL}	-0.5	-	V	3
	Storage Temperature	T_S	-65	150	°C	3
6	Input ESD protection	V_{DD-IN}	2000		V	2

* Exceeding these values may cause permanent damage

* Functional operation under these conditions is not implied

* Voltages are with respect to ground (GND) unless otherwise stated

1. Maximum V_{IH} is not to exceed maximum V_{DD} .
2. Human body model.
3. Consult manufacturer regarding extended operation in excess of normal DC operating parameters.

DC Electrical Specification

Table 14 DC Operating Characteristics*

	Parameter	Sym.	Min.	Typ.	Max.	Units	Notes
1	3.3 V Core Supply Voltage	V _{DD,A}	3.135	3.3	3.465	V	
2	3.3 V I/O Supply Voltage	V _{DD}	3.135	3.3	3.465	V	
3	3.3 V Input High Voltage	V _{IH}	2.0		V _{DD} +0.3	V	
4	3.3 V Input Low Voltage	V _{IL}	V _{SS} -0.3		0.8	V	
5	Input Leakage Current	I _{IL}	-5		+5	μA	
6	Input Low Voltage, 3-level CMOS Input	V _{IL3}	V _{SS} -0.3		0.9	V	
7	Input Midrange Voltage, 3-level CMOS Input	V _{IM3}	1.3		1.8	V	
8	Input High Voltage, 3-level CMOS Input	V _{IH3}	2.4		V _{DD}	V	
9	Input Capacitance	C _{IN}			4.5	pF	1
10	Output Capacitance	C _{OUT}			4.5	pF	1
11	Ambient Temperature	T _A	-40		85	°C	

* Voltages are with respect to ground (GND) unless otherwise stated
1 For parasitic simulation use IBIS model.

Table 15 Differential DC Output Characteristics*

	Parameter	Sym.	Min.	Typ.	Max.	Units	Notes
1	Maximum Voltage (Overshoot)	V _{ovs}			V _{high} + 75	mV	1
2	Maximum Voltage (Undershoot)	V _{uds}			V _{low} - 75	mV	1
3	Voltage High	V _{high}	225		270	mV	1
4	Voltage Low	V _{low}	10		150	mV	1
5	Absolute Crossing Point Voltages	V _{cross absolute}	130		200	mV	1
6	Relative Crossing Point Voltages	V _{cross relative}			35	mV	1
7	Output Buffer Differential Impedance	DiffZ	85-5%		85+5%	Ω	2
8	Output Buffer Differential Impedance	DiffZCrossing	85-20%		85+20%	Ω	3

* Voltages are with respect to ground (GND) unless otherwise stated
1 Measured into DC testload, see Figure 15
2 Measured at VOL / VOH.
3 Measured during a transition

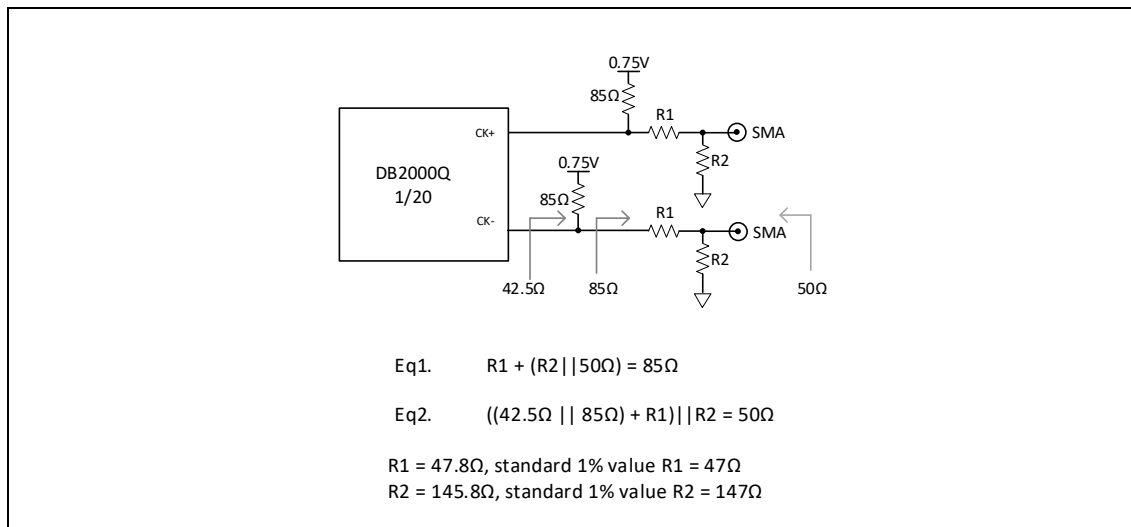

Figure 15. DC Test Load (as per DB2000Q Specification)

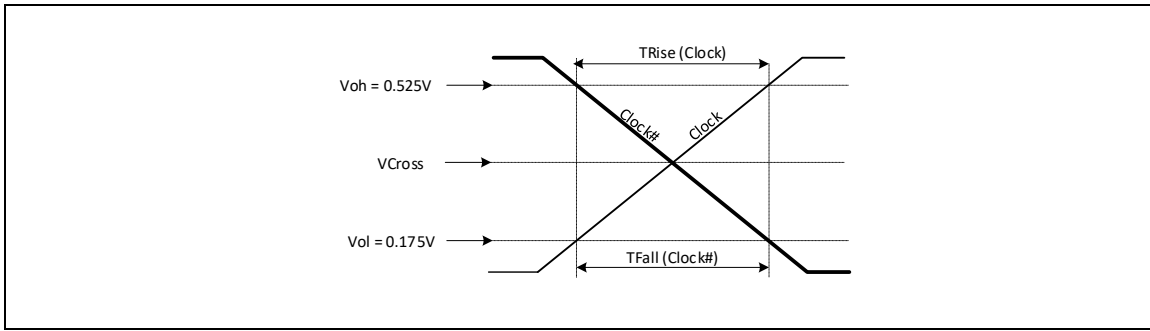

Figure 16. Single-Ended Measurement Points for TRise and TFall

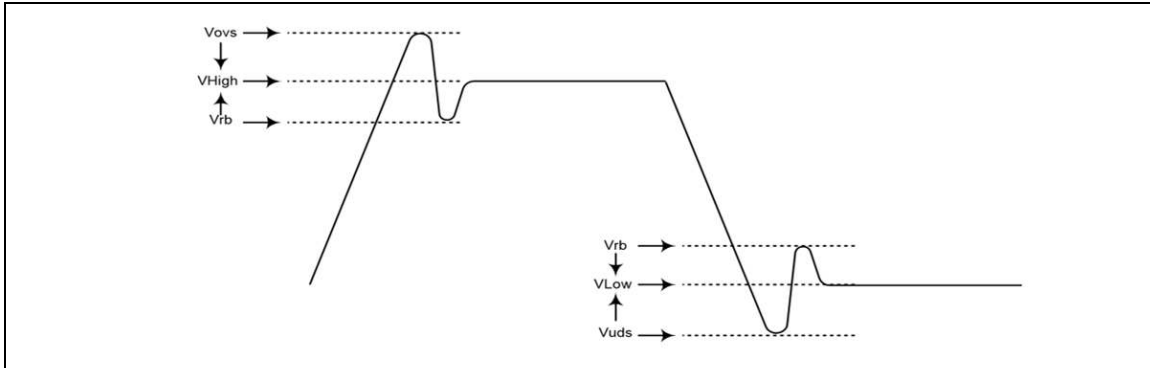

Figure 17. Single-Ended Measurement Points for Vovs, Vuds, Vrb

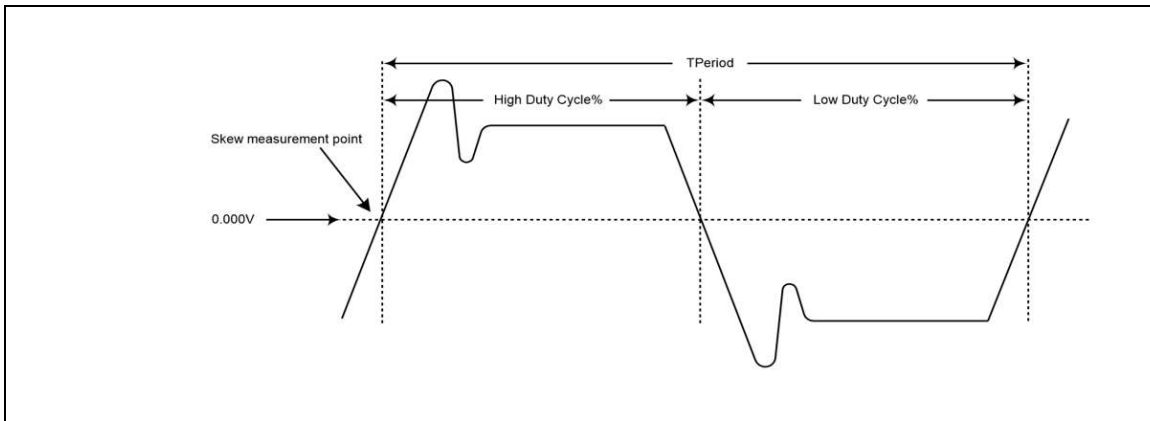

Figure 18. Differential (CK, CK#) Measurement Points

AC Electrical Specification

Table 16 Power Noise Tolerance*

	VDD Electrical Noise Range	Symbol	Min.	Typ.	Max	Units	Notes
1	$f_{NOISE} = 12\text{kHz to } 20\text{MHz}$	N_{VDD_MID}	100			mV,p-p	1,2,3
2	$f_{NOISE} > 20\text{MHz}$	N_{VDD_HIGH}	50			mV,p-p	1,2,3
3	$f_{NOISE} = 12\text{kHz to } 20\text{MHz}$	$N_{VDD_A_MID}$	40			mV,p-p	1,2,3
4	$f_{NOISE} > 20\text{MHz}$	$N_{VDD_A_HIGH}$	20			mV,p-p	1,2,3

* The device meets all specification in the presence of noise specified in this table

- 1 Jitter and electrical characteristics are met with specified AC noise present on any of the power pins.
- 2 Over the specified frequency range, a single sinusoid tone should be assumed swept as the worst case.
- 3 Maximum measured frequency for VDD was 650kHz and for VDD_A the maximum frequency was 900kHz due to limitation of the test setup.

Table 17 Skew and Jitter

	Parameter	Symbol	Min.	Typ.	Max	Units	Notes
1	Input-to-Output Delay	I/O_{DELAY}	0.9		1.5	ns	1,3
2	Output-to-Output Skew	O/O_{DELAY}			50	ps	1,2
3	RMS Additive Jitter as per DB2000Q Spec	$A_{J_{RMS}}$		15	20	fs RMS	1,2,4
4	Peak-to-Peak Additive Jitter	$p-pA_{J_{RMS}}$			0.7	ps	1,2
5	Additive Jitter as per PCIe 1.0 (1.5MHz to 22MHz)	$T_{jPCIe_1.0}$		0.7	0.8	ps RMS	1, 2
6	Additive Jitter as per PCIe 2.0 high band (1.5MHz to 50MHz)	$T_{jPCIe_2.0_high}$		75	94	fs RMS	1, 2
7	Additive Jitter as per PCIe 2.0 low band (10kHz to 1.5MHz)	$T_{jPCIe_2.0_low}$		20	28	fs RMS	1, 2
8	Additive Jitter as per PCIe 2.0 mid band (5MHz to 16MHz)	$T_{jPCIe_2.0_mid}$		59	74	fs RMS	1, 2
9	Additive Jitter as per PCIe 3.0 (PLL_BW = 2 to 5MHz, CDR = 10MHz)	$T_{jPCIe_3.0}$		19	24	fs RMS	1, 2
10	Additive Jitter as per PCIe 4.0 (PLL_BW = 2 to 5MHz, CDR = 10MHz)	$T_{jPCIe_4.0}$		19	24	fs RMS	1, 2
11	Additive Jitter as per PCIe 5.0 (PLL_BW = 0.5 to 1.8MHz, CDR for 32 GT/s CC)	$T_{jPCIe_5.0}$		7.5	10	fs RMS	1, 2
12	Additive jitter as per Intel QPI 9.6Gbps	T_{jQPI}		35	45	fs RMS	1, 2
13	Additive RMS jitter in 1MHz to 20MHz band	T_{j1M_20M}		49	62	fs RMS	1, 2 (100MHz clock)
				40	54	fs RMS	1, 2 (133MHz clock)
14	Additive RMS jitter in 12kHz to 20MHz band	T_{j12k_20M}		52	65	fs RMS	1, 2 (100MHz clock)
				42	56	fs RMS	1, 2 (133MHz clock)
15	Noise floor	N_F		-164	-163	dBc/Hz	1, 2 (100MHz clock)
				-163	-162	dBc/Hz	1, 2 (133MHz clock)

1. Measured into AC test load as per Figure 19.
2. Measured from differential crossing point to differential crossing point.
3. Input-to-output specs refer to the timing between an input edge and the specific output edge created by it.
4. Integrated after the measurement filter. See Intel DB2000Q specification Jitter Measurement section for the measurement filter details.

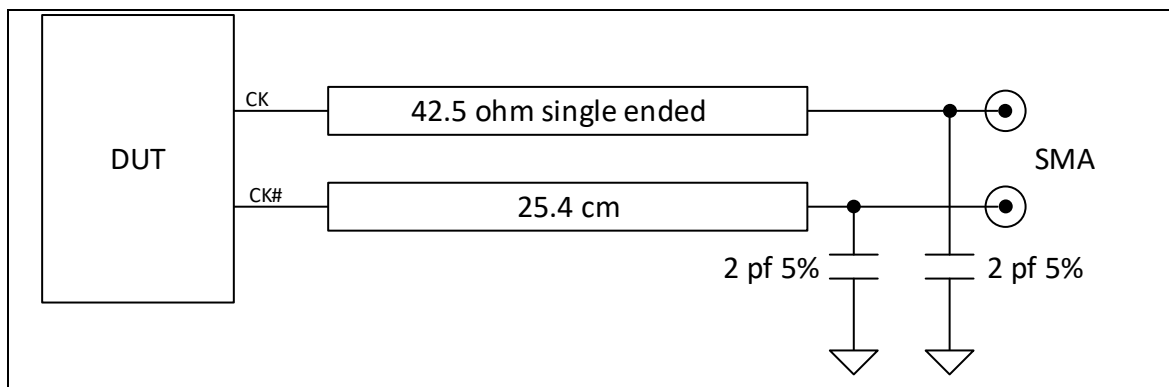

Figure 19. AC Test Load as per DB2000Q Specification

Table 18 Differential Output Clock AC Characteristics

	Parameter	Symbol	Min.	Typ.	Max.	Units	Notes
1	Clock Stabilization Time from PWRGD	Tstab			0.1	ms	4
2	Edge_rate at Vcross	Edge_rate	2.75		5	V/ns	1
3	Slew rate at Vcross	Rise/Fall_Matching			5%	V	1

1. Measured into Figure 19 AC test load.

Table 19 Differential Input Clock AC Characteristics

	Parameter	Symbol	Min.	Typ.	Max.	Units	Notes
1	Edge_rate	Input_Slew_Rate	0.7			V/ns	
2	Total Variation of Vcross Over All Edges	Total_Δ_Vcross			140	mV	
3	Input Voltage	Input_Voltage	200			mv diff	

Table 20 Current Consumption

	Parameter	Parameter Condition	Symbol	Min.	Typ.	Max	Units	Notes
1	Active Mode Supply Current	f _{IN} = 100MHz All CK_xP/N outputs enabled	I _{DDPG}		196	210	mA	1,2
2		f _{IN} = 100MHz All CK_xP/N outputs disabled			46	50		1,3
3		f _{IN} = 133MHz All CK_xP/N outputs enabled			203	220		1,2
4		f _{IN} = 133MHz All CK_xP/N outputs disabled			46	51		1,3
5	Power Down Mode Supply Current	f _{IN} = 100MHz	I _{DDPD}		21	25	mA	1,4
6		f _{IN} = 133MHz			22	26		1,4

1. VDD = 3.3V + 5%

2. Device operating in active mode (Pin PWRGD/PWRDN_N = 1) with all 20 CK_xP/N outputs enabled (all OE_xN pin = 0, all OCR1, OCR2, OCR3 register OEx bits = 1)

3. Device operating in active mode (Pin PWRGD/PWRDN_N = 1) with all 20 CK_xP/N outputs disabled (all OCR1, OCR2, OCR3 register OEx bits = 0)

4. Device operating in low power mode (Pin PWRGD/PWRDN_N=0)

SMBus Electrical Characteristics

Table 21 SMBus Electrical Characteristics

	Parameter	Symbol	Min.	Typ.	Max	Units	Notes
1	Nominal Bus Voltage	VDD _{SMB}	2.7		5.5	V	1
2	Input Low Voltage	V _{IL}			0.8	V	
3	Input High Voltage	V _{IH}	2.1		VDD _{SMB}	V	
4	Output Low Voltage	V _{OL}			0.4	V	At I _{PULLUP,MAX}
5	Input Leakage Current	I _{LEAK}			±10	µA	
6	Current sinking at V _{OL,max}	I _{PULLUP}	4			mA	
7	Pin capacitive load	C _I			12	pF	
8	Signal noise immunity from 10MHz to 100MHz	V _{NOISE}	300			mV _{p-p}	
9	Noise spike suppression time	T _{SPIKE}	0		50	ns	3
10	SMBus Operating Frequency	F _{SMB}	10		400	kHz	
11	Bus free time between Stop and Start Condition	T _{BUF}	4.7			µs	
12	Hold time after (Repeated) Start Condition. After this period, the first clock is generated.	T _{HD,STA}	4.0			µs	
13	Repeated Start Condition setup time	T _{SU,STA}	4.7			µs	
14	Stop Condition setup time	T _{SU,STO}	4.0			µs	
15	Data hold time	T _{HD,DAT}	300			ns	
16	Data setup time	T _{SU,DAT}	250			ns	
17	Clock low period	T _{LOW}	4.7			µs	
18	Clock high period	T _{HIGH}	4.0		50	µs	
19	Clock/Data Fall Time	T _F			300	ns	2
20	Clock/Data Rise Time	T _R			1000	ns	2

- 3V to 5V ±10%
- Rise and fall time is defined as follows:
 $T_R = (V_{IL,MAX} - 0.15) \text{ to } (V_{IH,MIN} + 0.15)$
 $T_F = (V_{IH,MIN} + 0.15) \text{ to } (V_{IL,MAX} - 0.15)$
- Devices must provide a means to reject noise spikes of a duration up to the maximum specified value.

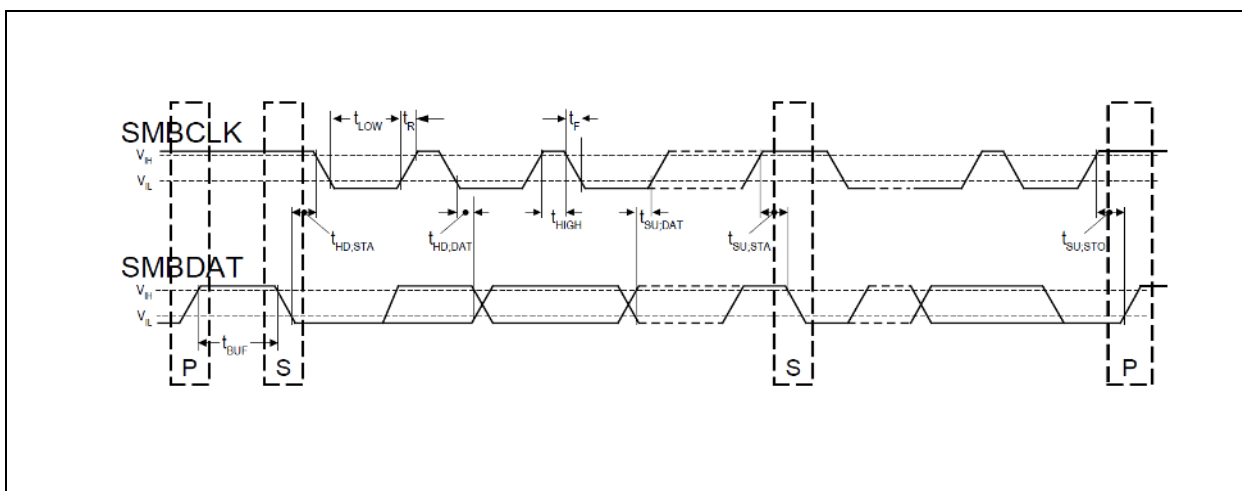

Figure 20. SMBus Timing

Table 22 10x10mm QFN Package Thermal Properties

Parameter	Symbol	Conditions	Value	Units
Maximum Ambient Temperature	T_A		85	°C
Maximum Junction Temperature	T_{JMAX}		125	°C
Junction to Ambient Thermal Resistance ⁽¹⁾ (Note 1)	θ_{JA}	still air	22.6	°C/W
		1m/s airflow	18.7	
		2.5m/s airflow	16.9	
Junction to Board Thermal Resistance	θ_{JB}		9.7	°C/W
Junction to Case Thermal Resistance	θ_{JC}		12.4	°C/W
Junction to Pad Thermal Resistance ⁽²⁾	θ_{JP}	Still air	5.1	°C/W
Junction to Top-Center Thermal Characterization Parameter	Ψ_{JT}	Still air	0.4	°C/W

- (1) Theta-JA (θ_{JA}) is the thermal resistance from junction to ambient when the package is mounted on a 4-layer JEDEC standard test board and dissipating maximum power
- (2) Theta-JP (θ_{JP}) is the thermal resistance from junction to the center exposed pad on the bottom of the package)

Package Outline

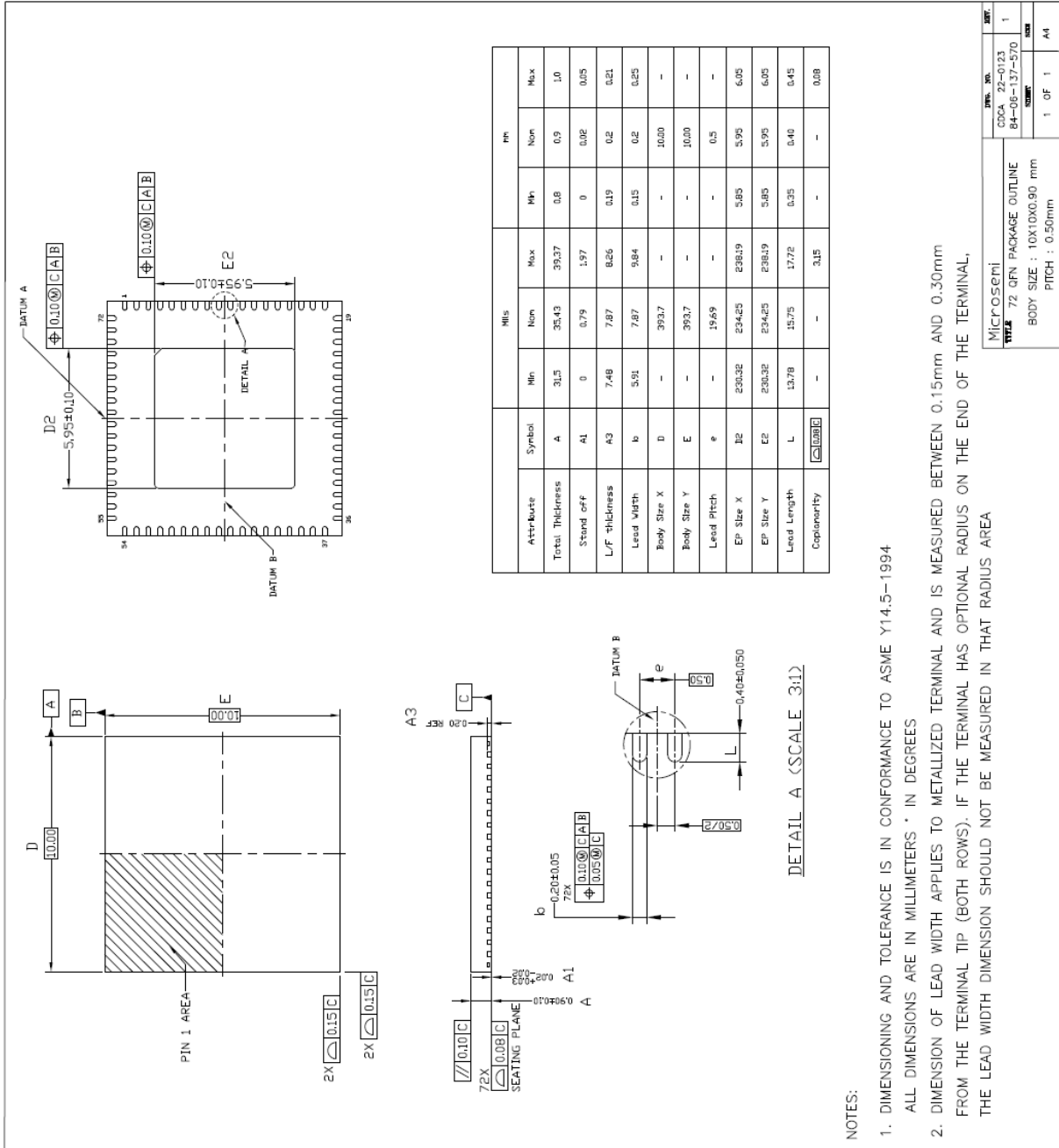

Microsemi		Doc. No.	72 QFN PACKAGE OUTLINE
Rev.	1	Doc. No.	84-08-137-570
Quantity	1	Doc. No.	1
Page	1	Doc. No.	1



Microsemi Corporate Headquarters

One Enterprise, Aliso Viejo,
CA 92656 USA

Within the USA: +1 (800) 713-4113

Outside the USA: +1 (949) 380-6100

Sales: +1 (949) 380-6136

Fax: +1 (949) 215-4996

E-mail: sales.support@microsemi.com

© 2019 Microsemi Corporation. All rights reserved. Microsemi and the Microsemi logo are trademarks of Microsemi Corporation. All other trademarks and service marks are the property of their respective owners.

Microsemi Corporation, a wholly owned subsidiary Microchip Technology Inc. (Nasdaq: MCHP), offers a comprehensive portfolio of semiconductor and system solutions for communications, defense & security, aerospace and industrial markets. Products include high-performance and radiation-hardened analog mixed-signal integrated circuits, FPGAs, SoCs and ASICs; power management products; timing and synchronization devices and precise time solutions, setting the world's standard for time; voice processing devices; RF solutions; discrete components; enterprise storage and communication solutions, security technologies and scalable anti-tamper products; Ethernet solutions; Power-over-Ethernet ICs and midspans; as well as custom design capabilities and services. Microsemi is headquartered in Aliso Viejo, California. Learn more at www.microsemi.com.

Microsemi makes no warranty, representation, or guarantee regarding the information contained herein or the suitability of its products and services for any particular purpose, nor does Microsemi assume any liability whatsoever arising out of the application or use of any product or circuit. The products sold hereunder and any other products sold by Microsemi have been subject to limited testing and should not be used in conjunction with mission-critical equipment or applications. Any performance specifications are believed to be reliable but are not verified, and Buyer must conduct and complete all performance and other testing of the products, alone and together with, or installed in, any end-products. Buyer shall not rely on any data and performance specifications or parameters provided by Microsemi. It is the Buyer's responsibility to independently determine suitability of any products and to test and verify the same. The information provided by Microsemi hereunder is provided "as is, where is" and with all faults, and the entire risk associated with such information is entirely with the Buyer. Microsemi does not grant, explicitly or implicitly, to any party any patent rights, licenses, or any other IP rights, whether with regard to such information itself or anything described by such information. Information provided in this document is proprietary to Microsemi, and Microsemi reserves the right to make any changes to the information in this document or to any products and services at any time without notice.