

REVISIONS					
P	LTR	DESCRIPTION	DATE	DMN	APVD
E1		REVISED PER ECO-18-009241	05SEP2018	K.G	W.H

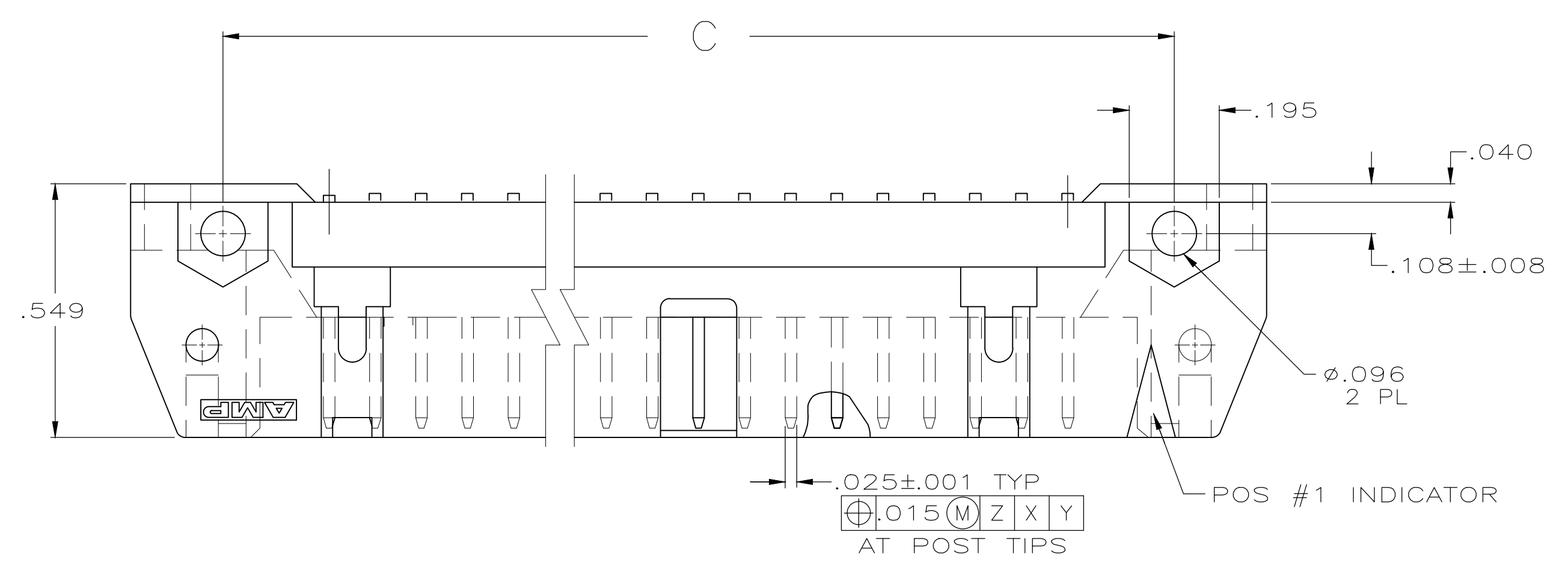

- 1 NO SNAP-IN POLARIZING FEATURE ON THIS END FOR 10 & 14 POS HEADERS.
- 2 POSTS: GOLD FLASH OVER PALLADIUM-NICKEL PLATE, .000030 MIN TOTAL ON THE LOCALIZED PLATE AREA, .000100 MIN TIN PLATE ON THE SOLDER-TAIL, .000050 MIN NICKEL UNDERPLATE ON THE ENTIRE POST.
-OR-
.000030 MIN GOLD PLATE ON THE LOCALIZED PLATE AREA, .000100 MIN TIN PLATE ON THE SOLDER-TAIL, .000050 MIN NICKEL UNDERPLATE ON THE ENTIRE POST.
- 3 RECOMMENDED STENCIL THICKNESS EQUALS .010
- 4 FOR 10 POS.HEADER ONLY, ONE SLOT LOCATED AS SHOWN.
- 5 MAXIMUM DISTANCE FROM EDGE OF PC BOARD FOR DAISY CHAIN APPLICATIONS
- 6 MOLDED PARTS: FLAME RETARDANT PCT, UL94V-0 RATED, COLOR RED.
POSTS: BRASS

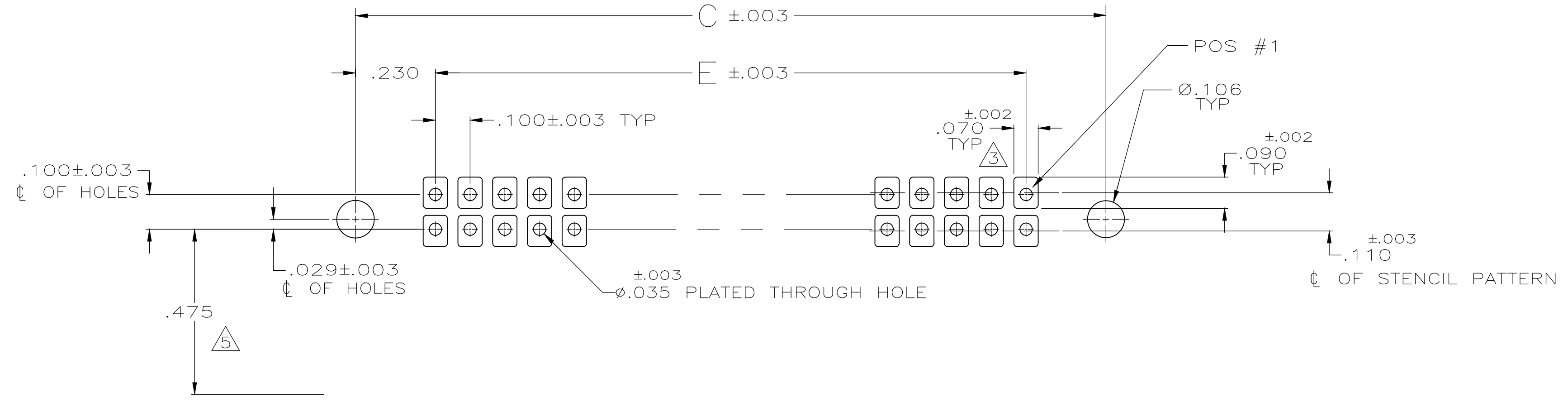
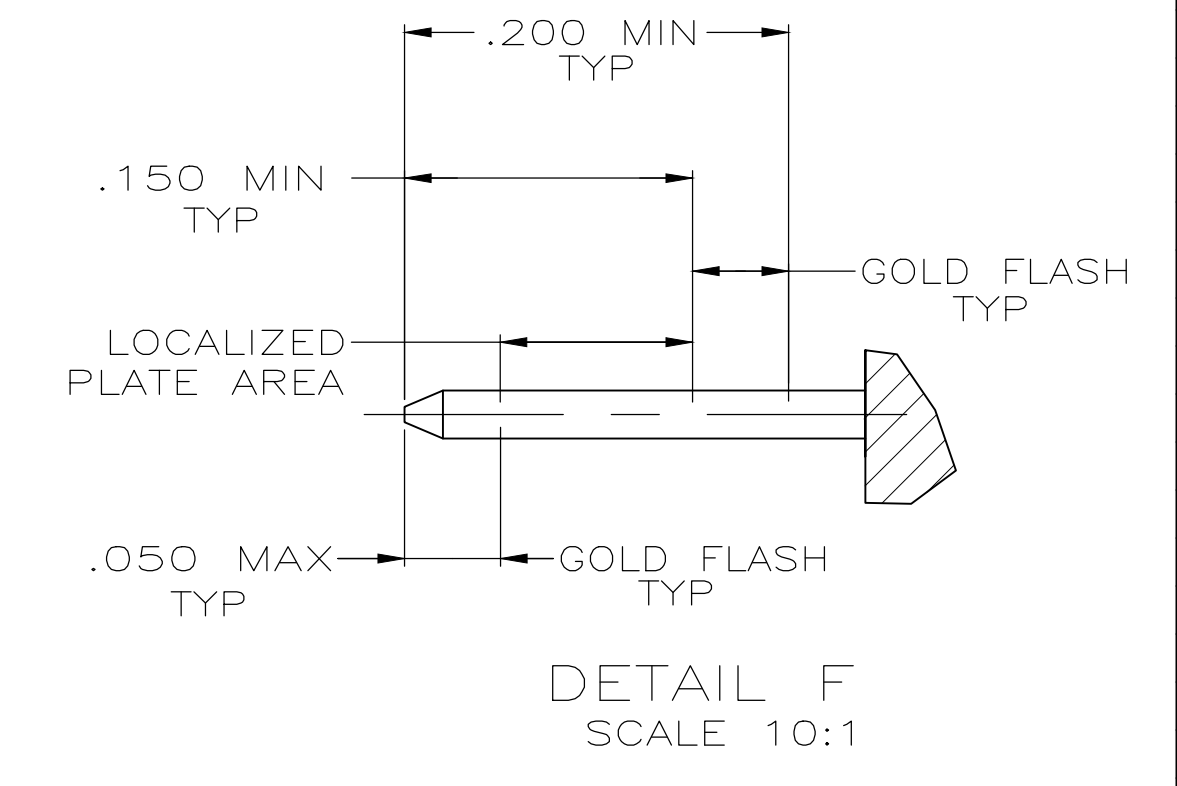
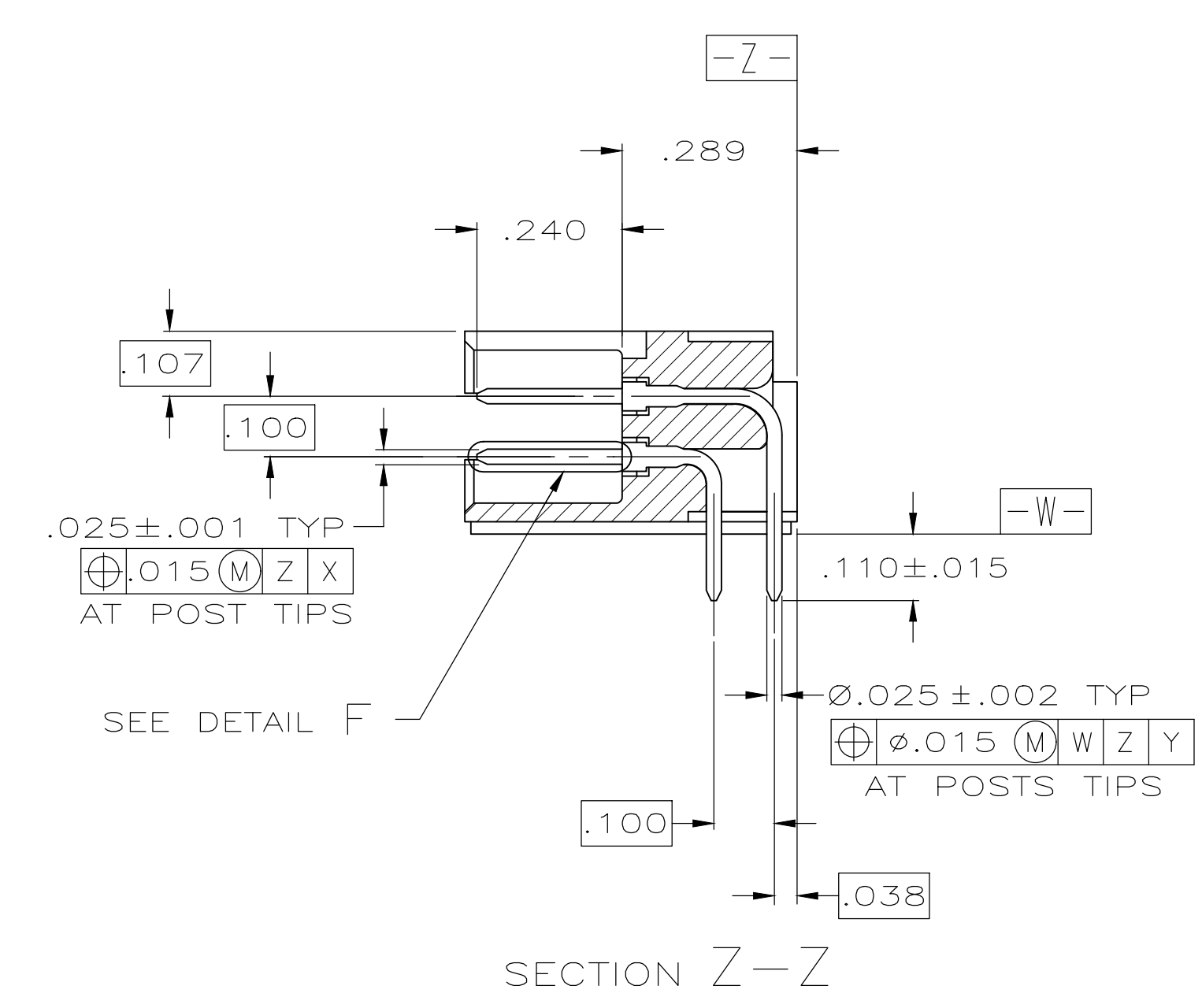
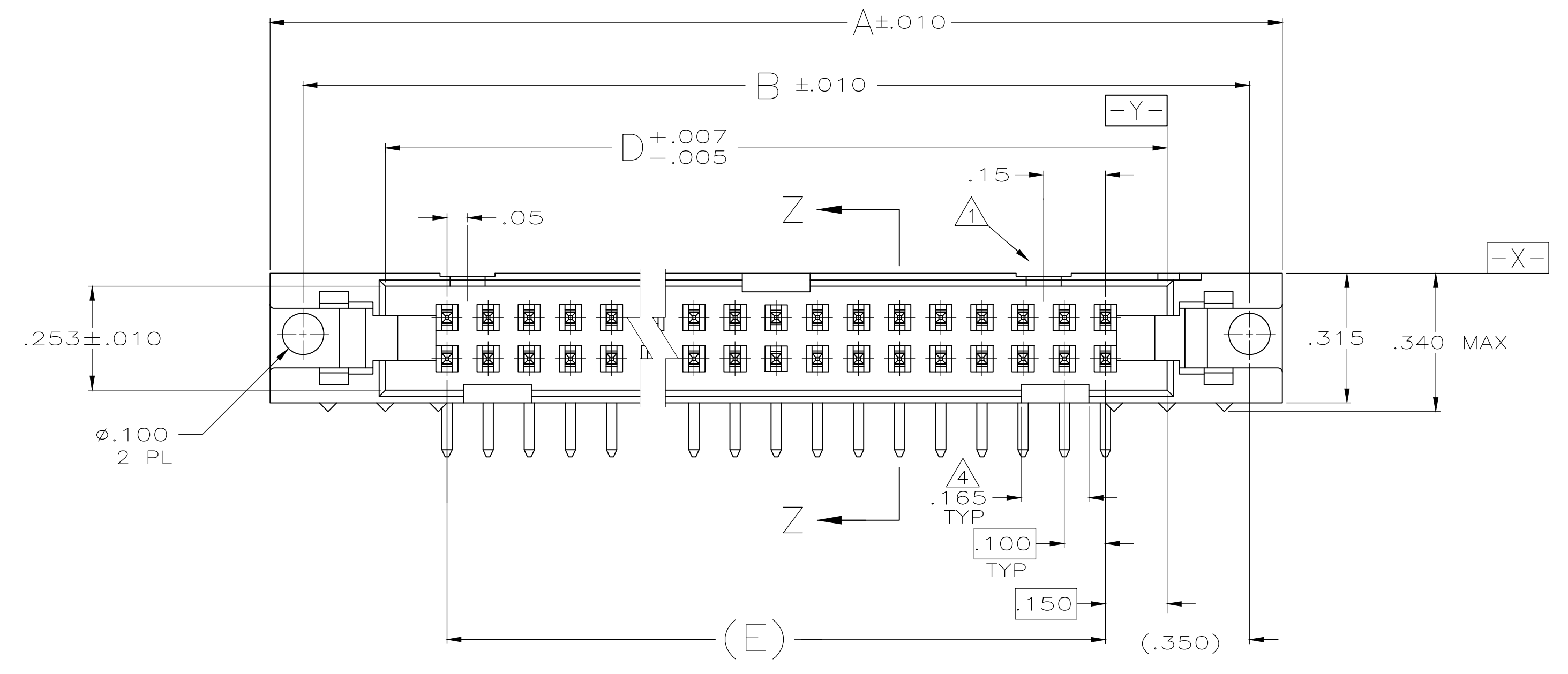

RECOMMENDED P C BOARD MOUNTING DIMENSIONS

3.100	3.400	3.560	3.80	3.96	64	1-5111105-2	
2.900	3.200	3.360	3.60	3.76	60	1-5111105-1	
2.400	2.700	2.860	3.10	3.26	50	1-5111105-0	
1.900	2.200	2.360	2.60	2.76	40	5111105-9	
1.600	1.900	2.060	2.30	2.46	34	5111105-8	
1.400	1.700	1.860	2.10	2.26	30	5111105-7	
1.200	1.500	1.660	1.90	2.06	26	5111105-6	
1.100	1.400	1.560	1.80	1.96	24	5111105-5	
.900	1.200	1.360	1.60	1.76	20	5111105-4	
.700	1.000	1.160	1.40	1.56	16	5111105-3	
.600	.900	1.060	1.30	1.46	14	5111105-2	
OBSOLETE	.400	.700	.860	1.10	1.26	10	5111105-1
	E	D	C	B	A	NO. OF POSN	
						PART NO	

THIS DRAWING IS A CONTROLLED DOCUMENT.

DIMENSIONS: INCHES	TOLERANCES UNLESS OTHERWISE SPECIFIED:	0 PLC ± -	1 PLC ± -	2 PLC ± -	3 PLC ± -	4 PLC ± -	ANGLES ± -
MATERIAL	FINISH	WEIGHT	0.000000	SIZE	A1	CAGE CODE	00779
CUSTOMER DRAWING		SCALE	4:1	SHEET	1 OF 1	REV	E1

APPROVED: M. WALMSLEY, DATE: 01-07-05

NAME: AMP-LATCH UNIVERSAL HEADER, RIGHT ANGLE. FOR VAPOR-PHASE APPLICATIONS

PRODUCT SPEC: 108-40018

APPLICATION SPEC: -

RESTRICTED TO: -