

**STRAIGHT PLUG FULL CRIMP-TYPE
CABLE 5/50 S**

R124.075.320
SERIES SMA-COM

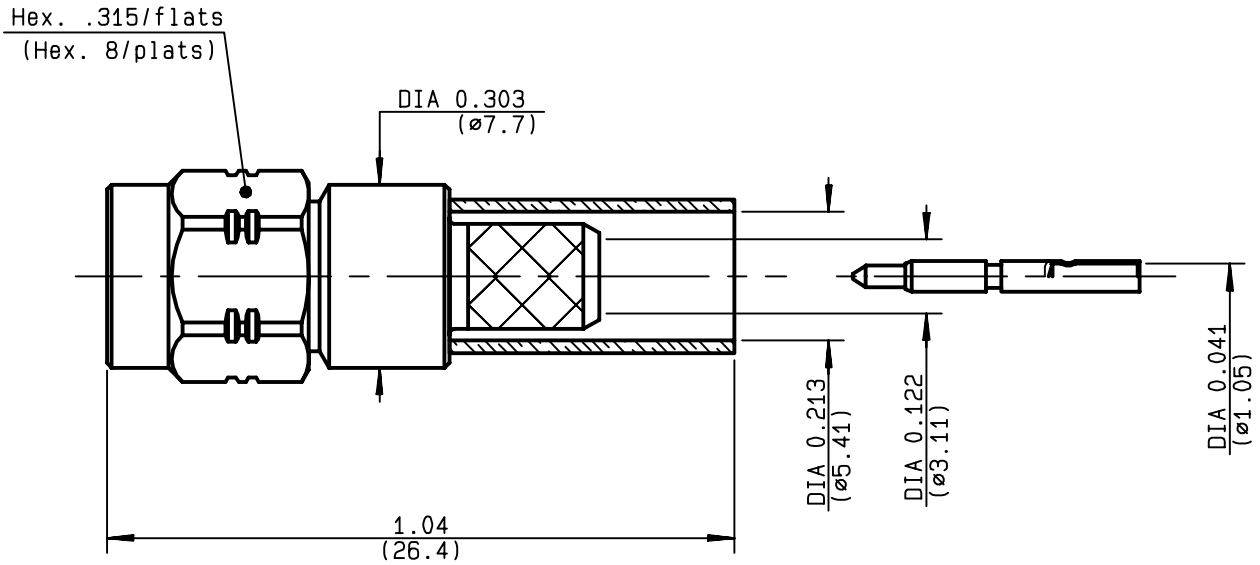

NOMINAL IMPEDANCE	50 Ω	CABLES : KX 15 RG 141 RG 58
FREQUENCY RANGE	0-12.4 GHz	
TEMPERATURE RATING	-65/+165 °C	
V.S.W.R	1.15 + .01 x F(GHz)Maxi	
RF INSERTION LOSS	0.05 √F(GHz) dB Maxi	
VOLTAGE RATING	335 Veff Maxi	
DIELECTRIC WITHSTANDING VOLTAGE	1000 Veff Mini	
INSULATION RESISTANCE	5000 MΩMini	
HERMETIC SEAL	NA Atm.cm ³ /s	
LEAKAGE (pressurized only)	NA	
MECHANICAL DURABILITY	100 Cycles	OTHERS CHARACTERISTICS
WEIGHT	5.2 gr	CABLE RETENTION 180 N Mini
SPECIFICATION		CENTER CONTACT RETENTION
		Axial force - mating end 18 N Mini
		Axial force - opposite end 18 N Mini
		Torque NA cm.N Mini
		RECOMMENDED TORQUES
		Mating 60 cm.N
		Panel nut NA cm.N
		Clamp nut NA cm.N

CONNECTOR PARTS	MATERIALS	FINISH	(all values are given in micrometers)
BODY	BRASS	BBR 2	
OUTER CONTACT			
CENTER CONTACT	BRASS	GOLD 1.3 OVER COPPER 2.5	
INSULATOR	PTFE	-	
GASKET		-	
OTHERS PIECES	BRASS	BBR 2	

ISSUE	CREATION DATE	FILE PART-NUMBER
9847B00	20/05/1996	96-1000-011



TRIQUES

The information given here is subject to change without notice.
Design changes may be in order to improve the product .

Connect to the future



R124.075.320

ISSUE 9847B00 SERIES SMA-COM

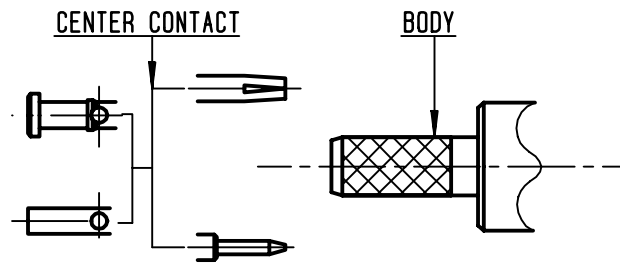
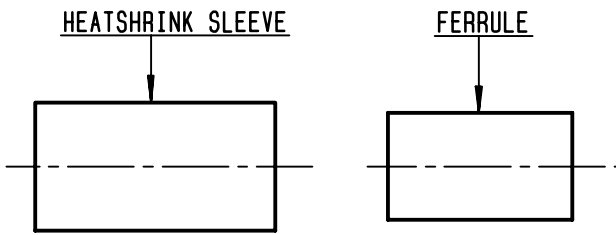

①

Slide heatshrink sleeve (R280.637.030-Option) and ferrule onto cable. Strip the cable.

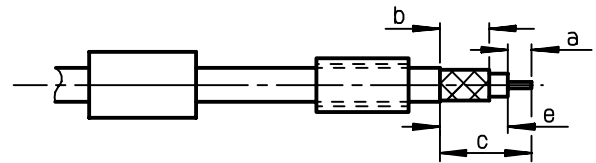

Stripping	a	b	c	d	e
inch	0.118	0.248	0.425	0	0.307
mm	3	6.3	10.8		7.8

②

Slide center contact on until it bottoms against cable dielectric. Solder or crimp center contact. Crimping tool : R282.281.000 (2 x 4 pts) position 7 + positionner R282.967.012.

SOLDER / CRIMPING

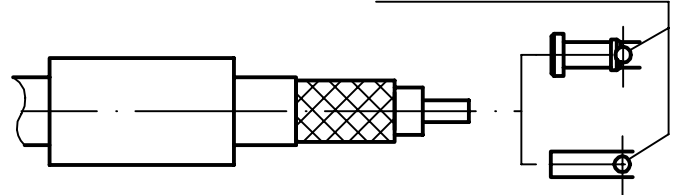

③

Fan the braid. Slide cable into the body by overtaking the insulator hard mounting point. Slide ferrule over the braid. (In direction F)

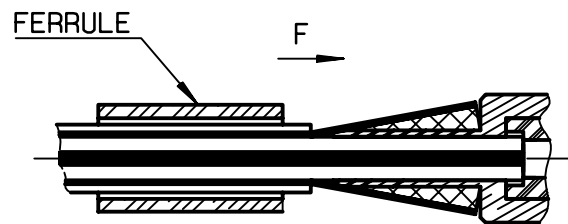

④

Crimp the ferrule with crimping tool R282.223.000 (Hex. : .213)(5.41) or crimping tool R282.293.000 (M22520/5-01) + dies R282.235.011 (M22520/5-11) Cut excess of braid if necessary. Slide sleeve over ferrule and heatshrink in place (Option)

Shrink the heatshrink sleeve

