

PRODUCT NO  
10084423-X01LF

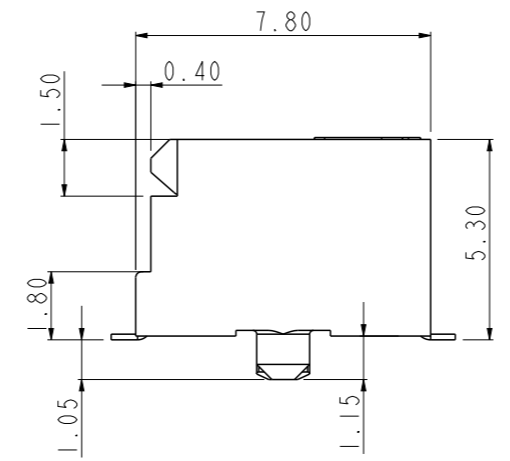

- NOTE:
- Material:
    - HOUSING: HIGH TEMPERATURE LCP, BLACK  
UL 94 V-0 FLAME RETARDANT.
    - TERMINAL: NICKEL COPPER ALLOY.  
PLATING SPEC AS BELOW:  
FOR CONTACT AREA:  
-101LF FOR 0.76 MICROMETERS MIN. THICKNESS GOLD.  
-201LF FOR 0.38 MICROMETERS MIN. THICKNESS GOLD.  
-901LF FOR 0.76 MICROMETERS MIN. THICKNESS GXT.
    - FOR SOLDER AREA:  
MATTE PURE TIN 3 MICROMETERS MIN.
    - FOR UNDERPLATING:  
2.54 MICROMETERS MIN. THICKNESS NICKEL
  - PACKING SPEC. GS-14-1030.
  - PRODUCT SPEC. GS-12-557.
  - PART NUMBER SCHEME: (EX. 10084423-X01LF),  
PLEASE FIND THE PAGE 2 FOR OPTIONS.
  - LEAD FREE NOTES:
    - 5a. THE HOUSING WILL WITHSTAND EXPOSURE TO 260° C PEAK TEMPERATURE FOR 10 SECONDS IN A CONVECTION, INFRA-RED OR VAPOR PHASE REFLOW OVEN.
    - 5b. THIS PRODUCT MEETS EUROPEAN UNION DIRECTIVES AND OTHER COUNTRY REGULATIONS AS DESCRIBED IN GS-22-008.
  - THIS CONNECTOR IS DESIGNED TO WORK WITH RAIL SYSTEM THAT ALLOW THE MODULE TO "FLOAT" IN THE VERTICAL PLANE AND FIND EQUILIBRIUM BETWEEN THE UPPER AND LOWER CONTACT ROWS. THIS CONNECTOR WILL NOT PERFORM PROPERLY IF USED IN SYSTEMS THAT MECHANICALLY BIAS THE MODULE IN THE VERTICAL PLANE SUCH AS RAIL SYSTEMS WITH EMI SPRINGS.

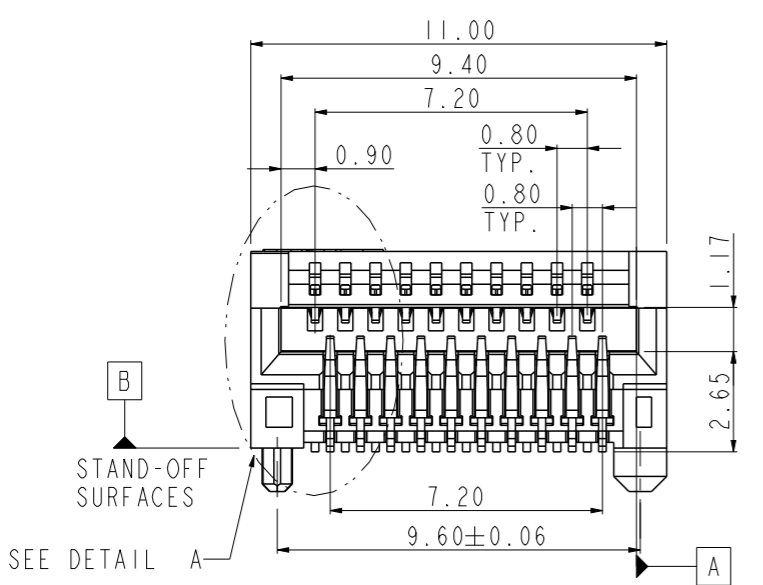
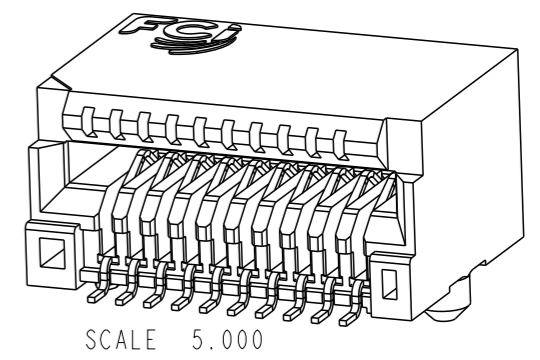
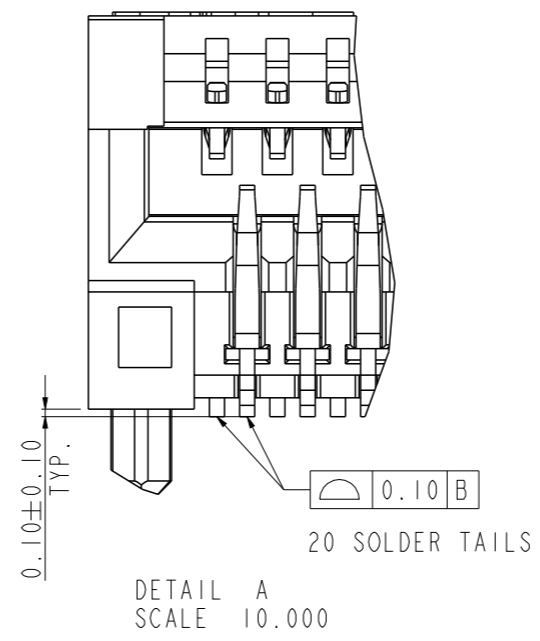
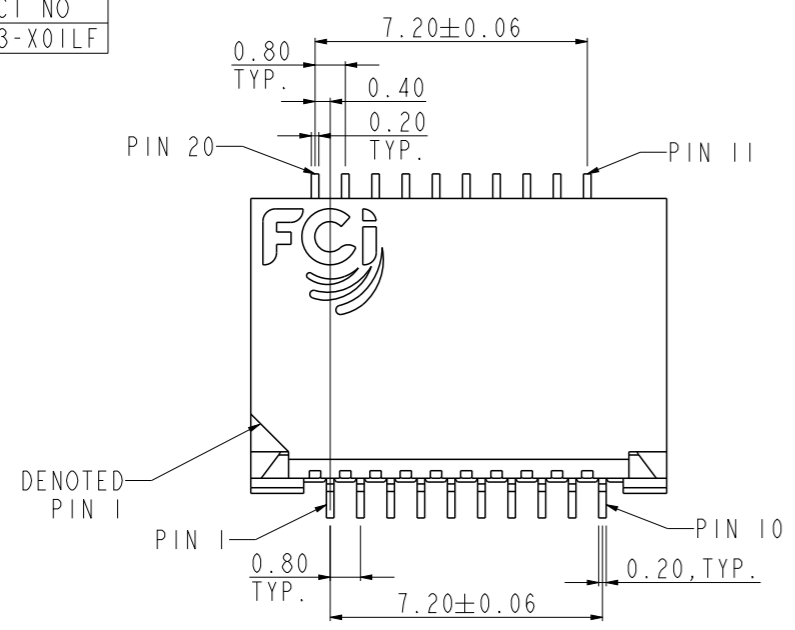
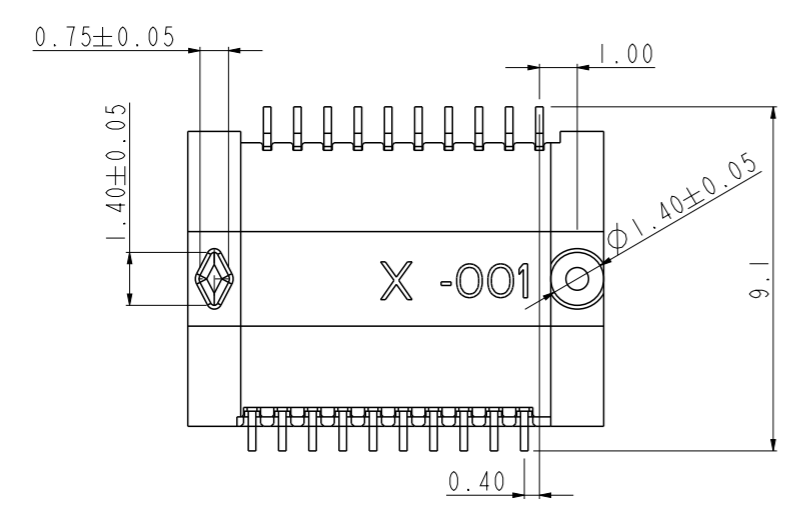

spec ref	*	dr	Junon Huang	2009/04/21	projection	MM	size	A3	scale	5.000
tolerance std	ISO 406 ISO 1101	eng	De-Feng, Qin	2012/03/22			ecn no	ELX-DG-010777-1	rel level	Released
TOLERANCES UNLESS OTHERWISE SPECIFIED		chr	Terry Qiu	2012/03/26						
surface	ISO 1302	appr	Pei-Ming Zheng	2012/03/26	product family					
	linear	0.X	±0.50		ASSEMBLY OF STANDARD TYPE.20 POS RIGHT ANGLE TYPE, EDGE CARD CONNECTOR	cat. no. *	Product - Customer Drw	sheet 1 of 2	rev E	dwg no 10084423-101
		0.XX	±0.25							
	angular	0°	±2°							

Copyright FCI.

PRODUCT NO  
10084423-X01LF

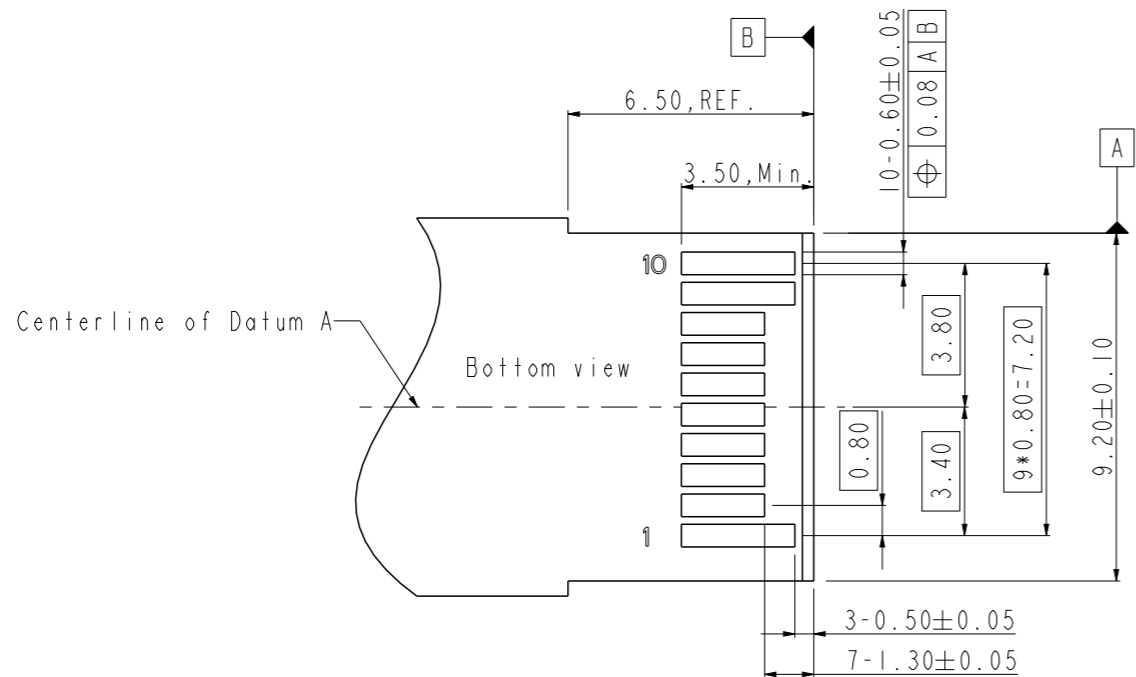
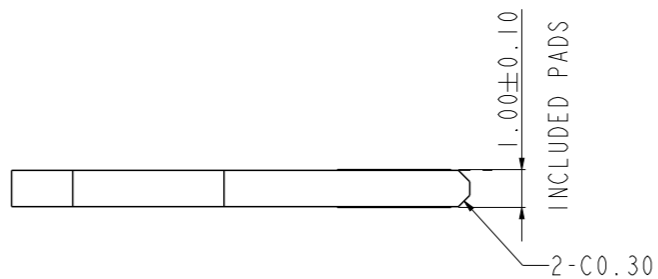
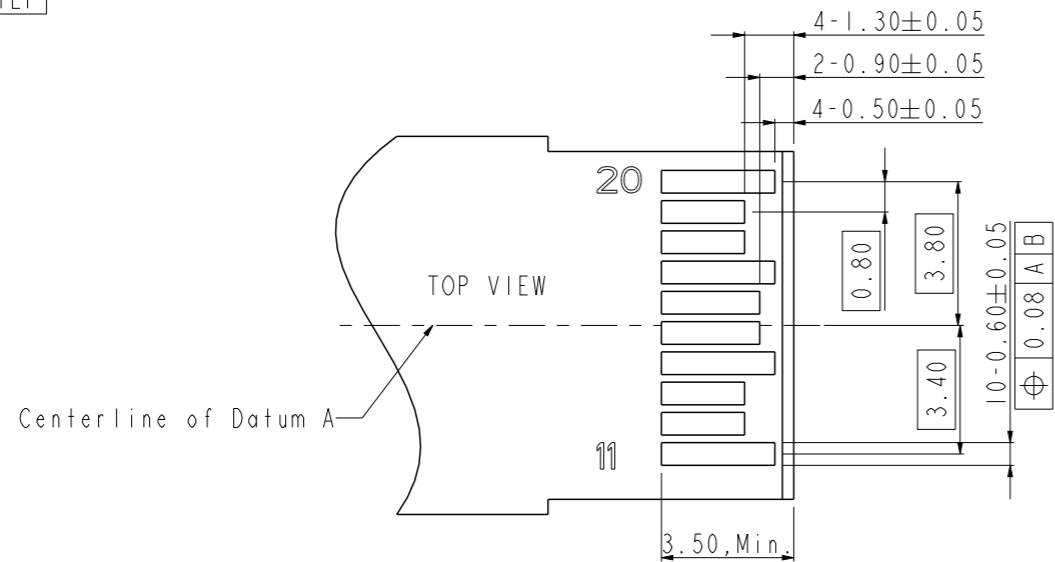

RECOMMENDED LAYOUT  
MATING PCB SIDE

PART NUMBER	TERMINALS (Contact plating options)	TERMINALS (Underplating and Solder tail plating)	REMARK
10084423-101LF	0.76um, Min.Gold	Underplating:2.54um Min. Nickel overall. Solder tail: 3um Min. Matte Tin.	
10084423-201LF	0.38um, Min. Gold	Underplating:2.54um Min. Nickel overall. Solder tail: 3um Min. Matte Tin.	
10084423-901LF	0.76um, Min.GXT	Underplating:2.54um Min. Nickel overall. Solder tail: 3um Min. Matte Tin.	

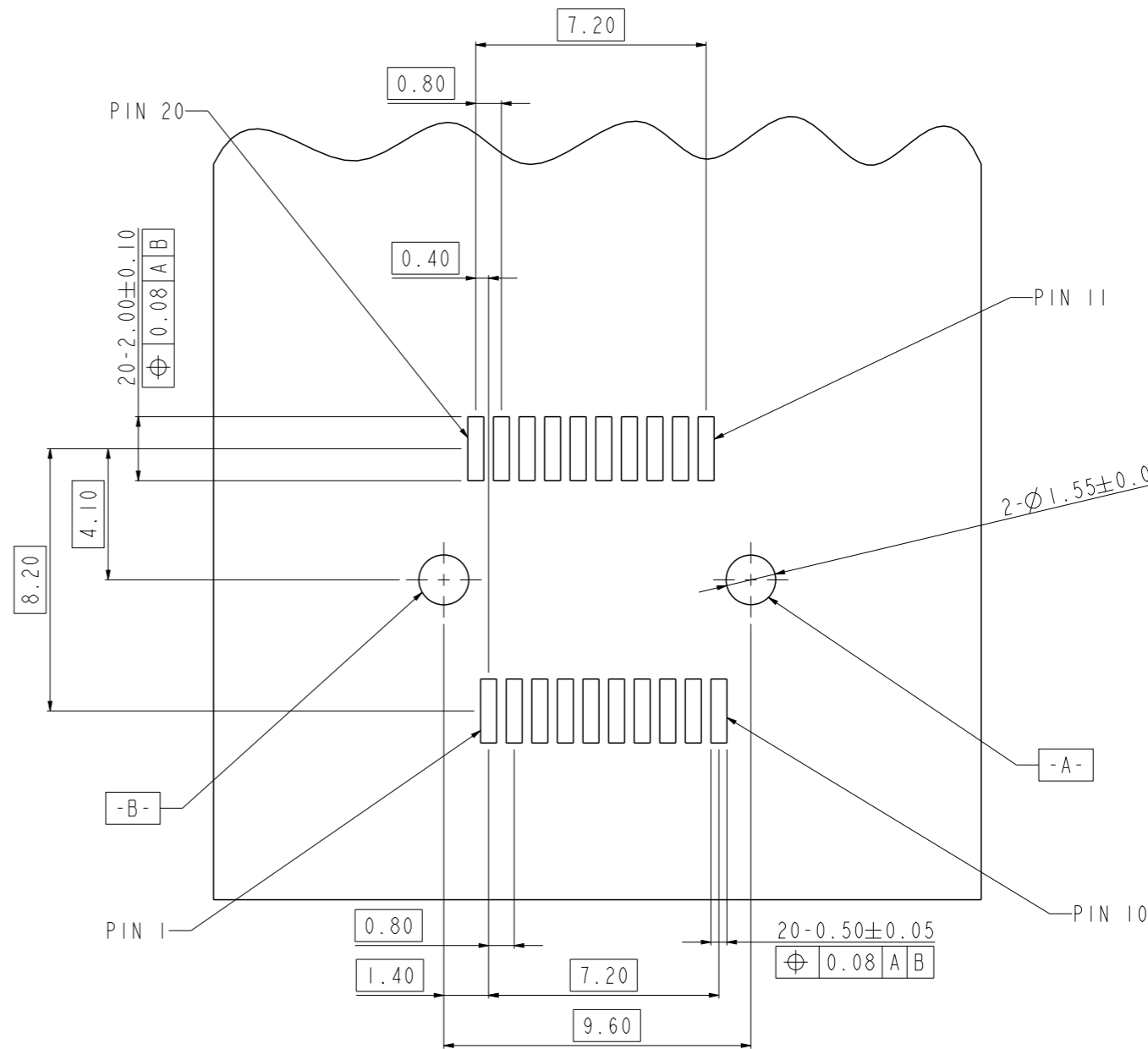

RECOMMENDED PCB LAYOUT  
CONNECTOR MOUNTING SIDE

spec ref	*	dr	Junon Huang	2009/04/21	projection	MM	size	A3	scale	5.000
tolerance std	ISO 406 ISO 1101	eng	De-Feng, Qin	2012/03/22			ecn no	ELX-DG-010777-1		
surface	ISO 1302	chr	Terry Qiu	2012/03/26			rel level	Released		
linear	0.X ±0.25 0.XX ±0.13 0.XXX ±0.05	appr	Pei-Ming Zheng	2012/03/26	product family		rel level	Released		
angular	0° ±2°				title ASSEMBLY OF STANDARD TYPE.20 POS RIGHT ANGLE TYPE,EDGE CARD CONNECTOR	dwg no 10084423-101	rev E			
		www.fci.com	cat. no.	*	Product - Customer Drw	sheet 2 of 2				



Copyright FCI.