

ezPyro™ SMD I²C Pyroelectric Infrared Sensor for Gas Sensing

Introduction

The ezPyro™ range of thin film digital pyroelectric IR sensor for gas detection and concentration measurement combines high quality sensors with a high level of configurable electronic integration in a small SMD package. High sensitivity combined with fast response times ensure rapid and accurate detection of target gases. These sensors integrate a digital, current mode read-out that enables lower IR-emitter duty cycles, thereby saving significantly on system level power consumption, while maintaining high SNR. Programmable gain and filtering offer maximum flexibility in system design. Industry standard I²C communication enables plug-and-play connectivity to microcontrollers and allows easy tuning and calibration. ezPyro sensors are very stable over time, ensuring a long and maintenance-free operational lifespan. Various optical filter options are available. These sensors can also be daisy-chained to allow synchronized sampling across devices.

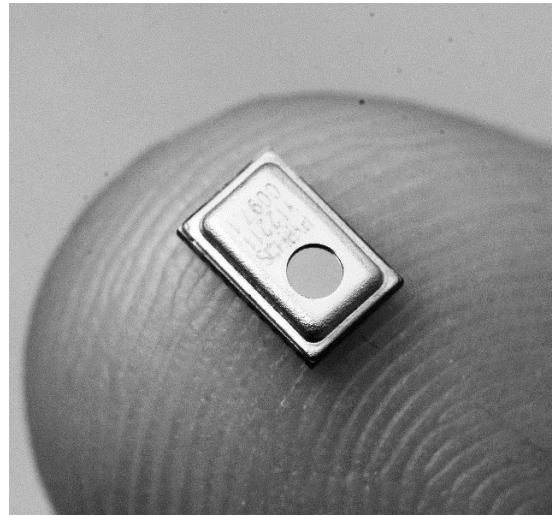

Sensor Characteristics

Filter aperture	d = 1.65 mm
Element size	0.64 x 0.64 mm ²
SMD Package	5.65 x 3.7 x 1.55 mm
D* (typ.) ¹	2.5 x 10 ⁸ cm [√] Hz/ W
NEP (typ.) ¹	2.7 x 10 ⁻¹⁰ W/√Hz
Time Constant	~10ms (10-20 Hz peak)
Field of View	~90°

Electrical Characteristics

Supply voltage	1.75 to 3.6 V
Supply current (typ.)	1 to 23 μA
Digital I/O	I ² C (FM+ compatible)
ADC	15bit ΔΣ ADC @1ksp
Operating Temperature	-40 to +85 °C
Storage Temperature	-40 to +110 °C
Sensor read-out	Current mode Gain / digital filtering / sampling rate / power modes
Configurable	

1) Measured without filter @ 500K, 10 Hz, room temperature

Order Information

Part Number	Marking	Filter μm	Filter BW μm	Gas	Package Size
AFBR-S6EPY12211R	Y12211	3.91	90	Reference	800 pcs on 7-in. tape and reel
AFBR-S6EPY12231R	Y12231	4.26	180	CO ₂	800 pcs on 7-in. tape and reel

Package Information

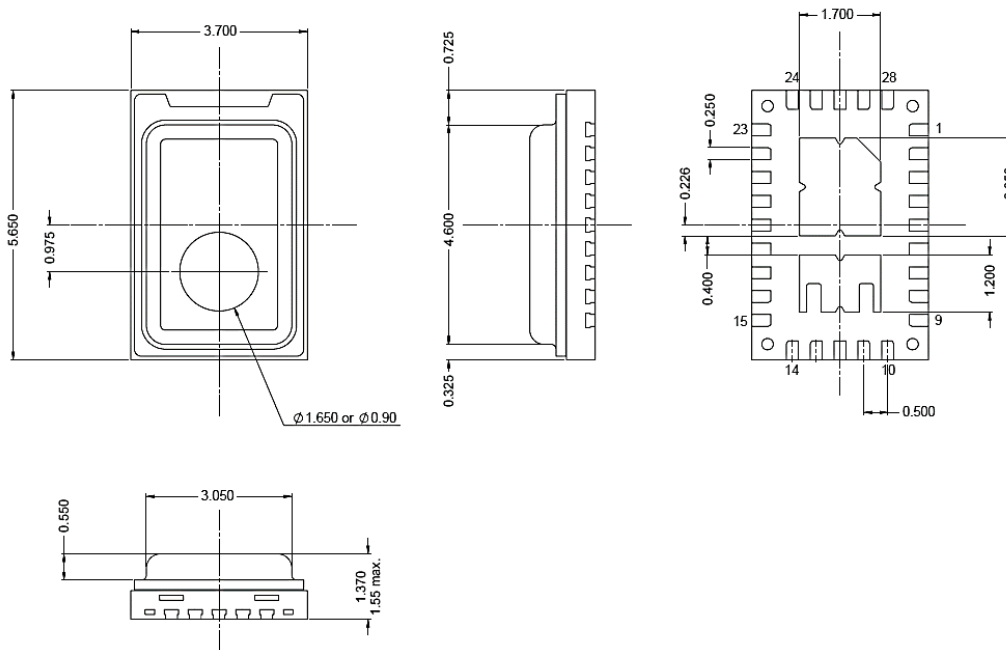

Signal Filtering & Power Modes

Power Mode (base sample rate)	High Pass Filter – Analog (Hz)					Fixed Analog Low Pass Filter (Hz)	Fixed Digital Low Pass Filter (Hz)	Digital Low Pass Filter (Hz)				Max ADC Sampling Rate (sps)
	Off	1	2	4	8			180	90	45	22.5	
Normal Power Mode	Off	1	2	4	8	600	250	180	90	45	22.5	1000
Low Power Mode	Off	0.17	0.33	0.66	1.3	100	42	30	15	7.5	3.75	166

	Mode	Description	Typical Current Consumption (1.8 V, room temperature)
Power consumption	Normal Power Mode	Normal power consumption, 1 kHz max. sample rate	22 μ A
	Low Power Mode	Low power consumption, 166 Hz max. sample rate	3.5 μ A
Operational state	Normal Operation Mode	Sensor signal readout over I ² C	22 μ A
	Sleep Mode	Hardware interrupt on infrared trigger	21 μ A (Normal), 3.5 μ A (Low)
	Power Down Mode	Sensor is disabled	1.1 μ A

Circuit Diagrams

Single Device Block Diagram

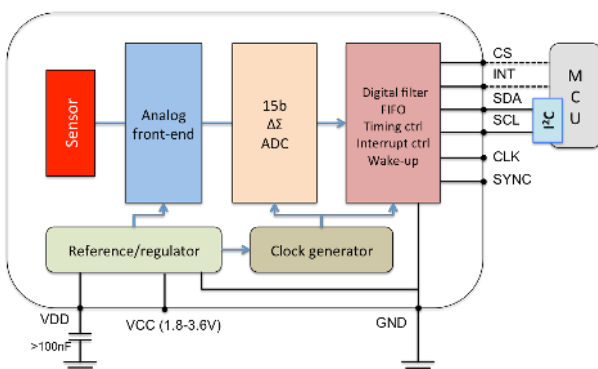

Three Devices with Synchronised Sampling

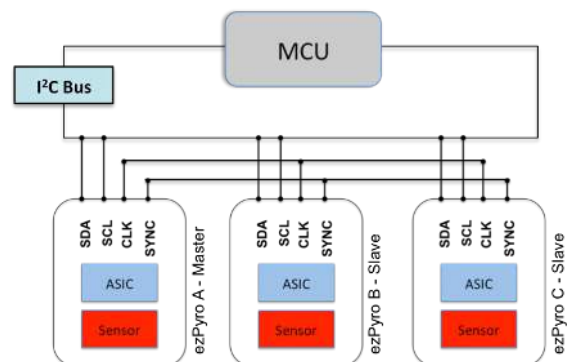

Infrared Frequency Characteristics

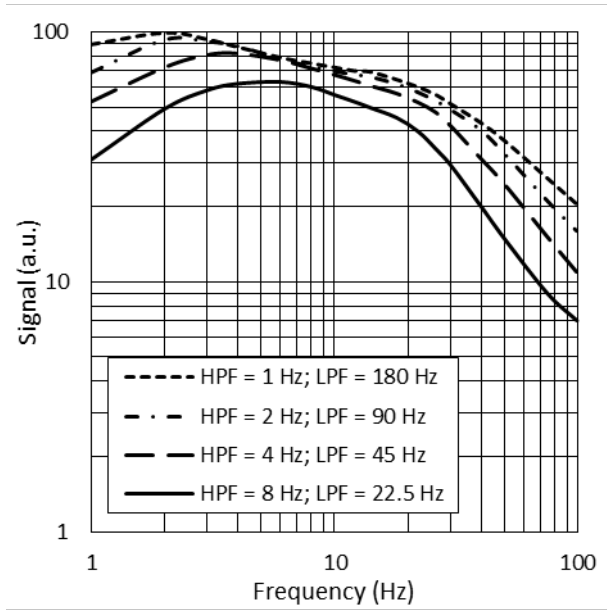

Typical Frequency Response in Normal Power Mode

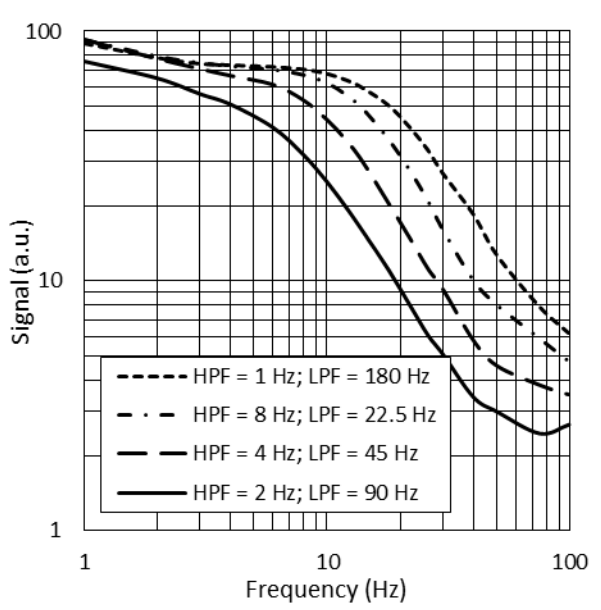

Typical Frequency Response in Low Power Mode

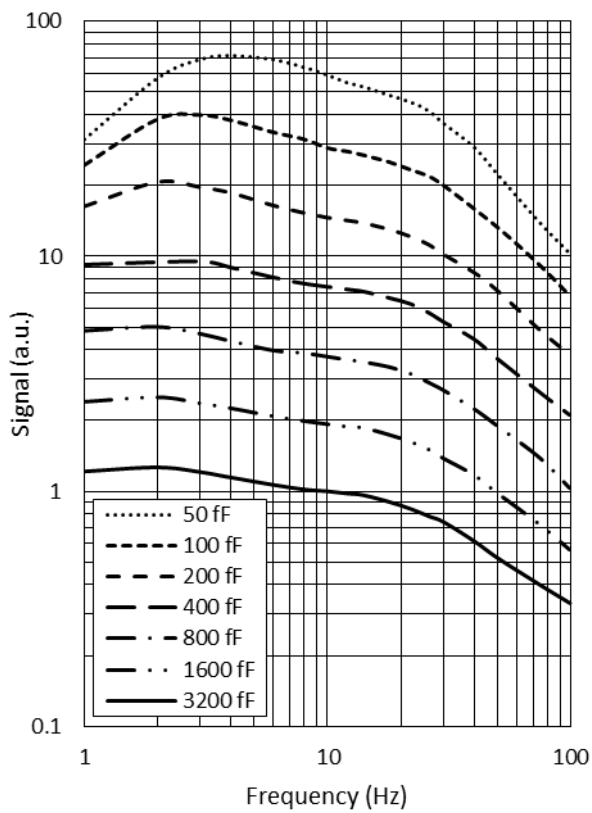

Typical Frequency Response at Different Gain Settings

Copyright © 2022 Broadcom. All Rights Reserved. The term “Broadcom” refers to Broadcom Inc. and/or its subsidiaries. For more information, go to www.broadcom.com. All trademarks, trade names, service marks, and logos referenced herein belong to their respective companies.

Broadcom reserves the right to make changes without further notice to any products or data herein to improve reliability, function, or design. Information furnished by Broadcom is believed to be accurate and reliable. However, Broadcom does not assume any liability arising out of the application or use of this information, nor the application or use of any product or circuit described herein, neither does it convey any license under its patent rights nor the rights of others.

AFBR-S6EPYSMD-GA-DS100