

THIS DRAWING IS UNPUBLISHED. RELEASED FOR PUBLICATION
 © COPYRIGHT - By - ALL RIGHTS RESERVED.

LOC	DIST	REVISIONS					
E	B	P	LTR	DESCRIPTION	DATE	DWN	APVD
		C1		REVISED PER ECO-11-005150	21MAR11	RK	HMR

NOTES:

- ELECTRICAL DATA: CONTACT RESISTANCE: 10 mOhm MAX
 INSULATION RESISTANCE: 100 MOhm MIN at 500VDC
 CURRENT RATING: 5 AMPS (FOR 3, 4 AND 5 POSITIONS) AND 2 AMPS (FOR 8 POSITION ONLY)
 BREAKDOWN VOLTAGE: 500 VAC MIN PER MINUTE
- ENVIRONMENTAL: OPERATING TEMPERATURE: -25°C TO +90°C
 SEALING REQUIREMENTS: IP67
- PACKAGING: 107-3334
- SEAL FOR CABLE OD: $\phi 4.5\text{mm}$ - $\phi 6.5\text{mm}$
- FOR TECHNICAL DATA REFER TO YOUR LOCAL TE CONNECTIVITY SALES OFFICE.
- ALL DIMENSIONS ARE FOR NOMINAL REFERENCE ONLY UNLESS OTHERWISE STATED.

ITEM	DESCRIPTION	MATERIAL	FINISH/COLOUR	QUANTITY / ITEM		
				-1	-2	-3
1	CONNECTOR HOUSING	GF NYLON	BLACK	1	1	1
2	GASKET	SILICONE	BLACK	1	1	1
3	CONNECTOR BODY	GF NYLON	BLACK	1	1	1
4	SEALING NUT	GF NYLON	BLACK	1	1	1
5	SEAL	EPDM	BLACK	1	1	1
6	SOCKET CONTACT	BRASS	0.15 μm GOLD OVER NICKEL	3	4	5
7	SCREW NUT	ZINC DIE CAST	2.5 μm NICKEL PLATED	1	1	1
8	'O' RING	VITON	GREEN	1	1	1

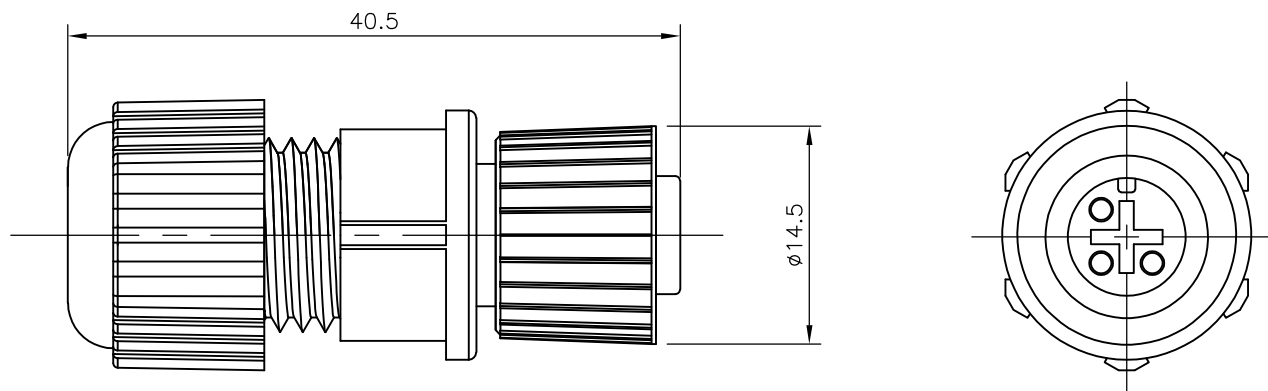
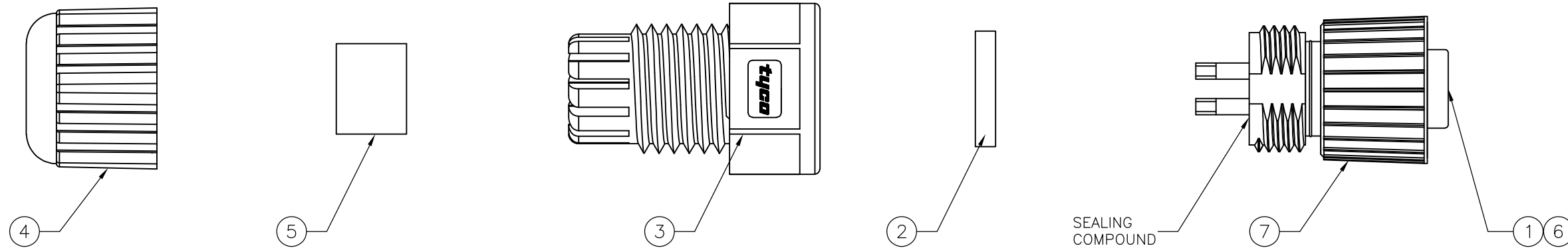

1838274-1
PIN ASSIGNMENTS
FRONT VIEW

1838274-2
PIN ASSIGNMENTS
FRONT VIEW

1838274-3
PIN ASSIGNMENTS
FRONT VIEW

1838274-4
PIN ASSIGNMENTS
FRONT VIEW

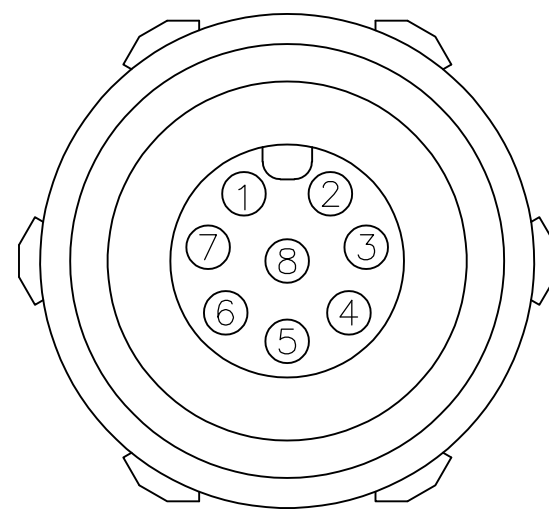
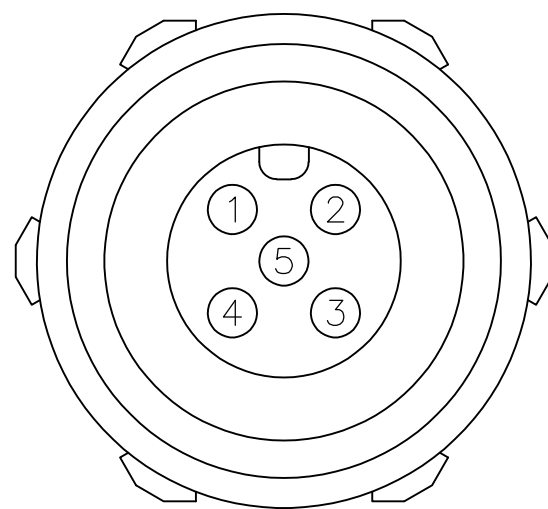
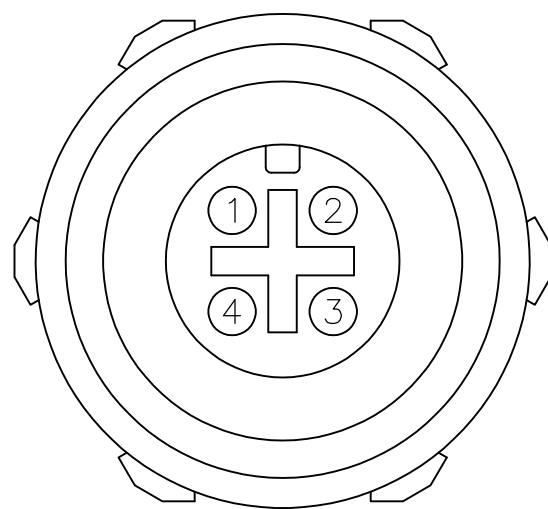
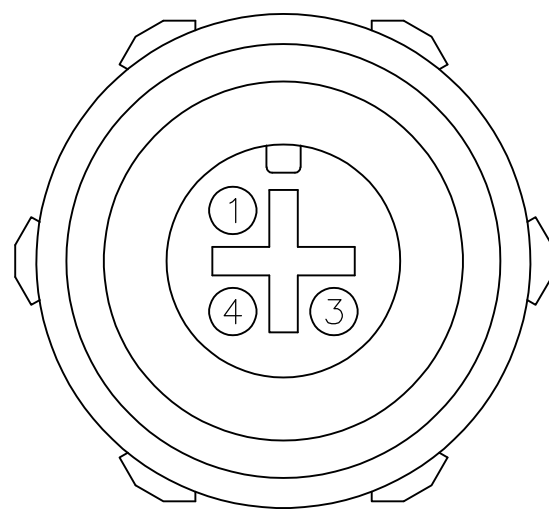

M12 FIELD SERVICEABLE CONNECTOR, FEMALE SOCKET, SOLDER TYPE	8	1838274-4
M12 FIELD SERVICEABLE CONNECTOR, FEMALE SOCKET, SOLDER TYPE	5	1838274-3
M12 FIELD SERVICEABLE CONNECTOR, FEMALE SOCKET, SOLDER TYPE	4	1838274-2
M12 FIELD SERVICEABLE CONNECTOR, FEMALE SOCKET, SOLDER TYPE	3	1838274-1
DESCRIPTION	NO. OF POS	PART NUMBER

THIS DRAWING IS A CONTROLLED DOCUMENT.

DWN	A. Morey	14MAR06
CHK	F. Wheeler-King	12APR06
APVD	F. Wheeler-King	12APR06
PRODUCT SPEC		
APPLICATION SPEC		
WEIGHT	-	
CUSTOMER DRAWING		

TE TE Connectivity

M12 FIELD SERVICEABLE CONNECTOR, FEMALE SOCKET, SOLDER TYPE

SIZE	A2	CAGE CODE	00779	DRAWING NO	C=1838274	RESTRICTED TO	-
SCALE	NTS	SHEET	1 OF 1	REV	C1		