

UNIT:MM

REVISION INFORMATION

Rev.	Rev. Date	Modified By	Brief Description
A/0	18-07-03	T0702A	NEW DRAWING
A/1	19-12-04	B1201A	increase DRAWING

PIN ASSIGNMENT:

P1		P2
1	RED	1
2	WHITE	2
3	GREEN	3
5	BLACK	4

SHELL DRAIN+BRAID SHELL

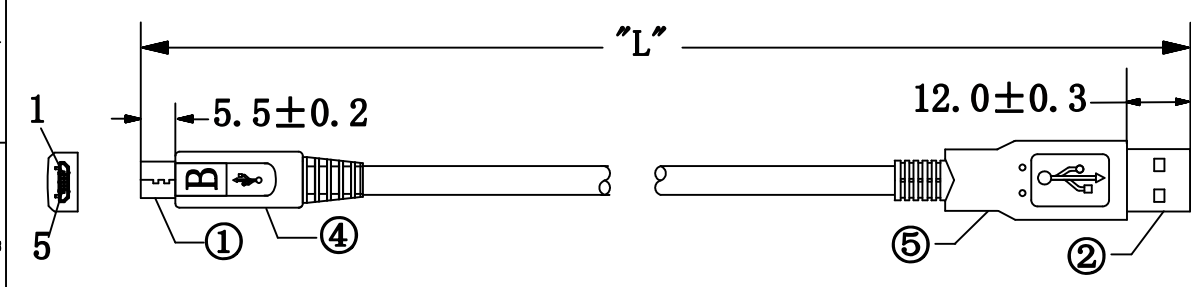

Electrical test:
 1. 100% short, open, miswire test
 2. Conduct resistance: 2 Ohm(max)
 3. Insulation resistance: 10Mohm(min)
 4. dielectric test: DC 300V

CABLE WHITE PRINT
 E166160 AWM 2725 80°C 30V
 28AWGX1P+28AWGX2C USB2.0

PART NO	WIRE LENGTH "L"	BUYER COLOR	VENDOR COLOR	CUT LENGTH
102-1092-BL-00100	1000±30		BLACK	985-990MM
102-1092-BL-00200	2000±30		BLACK	1985-1990MM
102-1092-BL-00300	3000±50		BLACK	2985-2990MM
102-1092-BL-00500	5000±60		BLACK	4985-4990MM

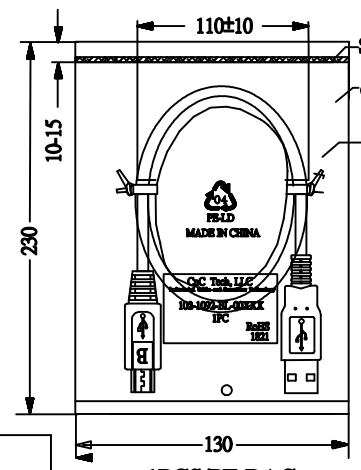

1PCS/PE BAG
102-1092-BL-00500

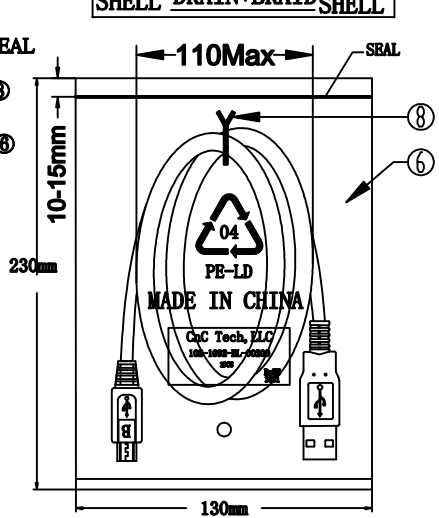

1PCS/PE BAG
 102-1092-BL-00100
 102-1092-BL-00200
 102-1092-BL-00300

NO.	NAME	QTY	SPECIFICATION
⑧	TIE	1	BLACK A/B:L=100mm, C/D:L=120mm
⑦	PE BAG	1/5	102-1092-BL-00500 CLEAR SIZE:280X330X0.05mm PRINT BLACK"MADE IN CHINA"+"5PCS"
		1/10	102-1092-BL-00300 102-1092-BL-00200 102-1092-BL-00100 CLEAR SIZE:280X330X0.05mm PRINT BLACK"MADE IN CHINA"+"10PCS"
		1	CLEAR SIZE:130X230X0.05mm PRINT BLACK"MADE IN CHINA"+"1PC"
⑥	PE BAG	1	CLEAR SIZE:130X230X0.05mm PRINT BLACK"MADE IN CHINA"+"1PC"
⑤	OUT JACKET	6g	BLACK PVC-55P (MOULD NO:2002-527)
④	OUT JACKET	6g	BLACK PVC-55P (MOULD NO:WM-116)
③	CABLE	1	USB2.0 UL2725 [28AWGX1P+28AWGX2C]+AEB JACKET:BLACK OD:3.8mm
②	CONN	1set	USB A MALE SHELL:NICKEL PIN G/F 3PCS TYPE INSULATOR COLOR:WHITE
①	CONN	1	MICRO USB 5P B/M SOLDER TYPE SHELL:NICKEL PIN:G/F INSULATOR COLOR:BLACK

CnC Tech, LLC
 Industrial Cable and Connector Technology

DRAWN BY:	DATE: 2019/12/04	DESCRIPTION: 4C CABLE USB A/M+MICRO USB
CHECKED BY:	SHEET 1 of 1	ITEM NO. As above
APPROVED BY:	SCALE 1:1	REV. A/1

UNIT: mm