



# MAX98302 Evaluation Kit

**Evaluates: MAX98302**

## General Description

The MAX98302 evaluation kit (EV kit) is a fully assembled and tested PCB that evaluates the MAX98302 stereo 2.4W Class D amplifier. The EV kit operates from a single 2.6V to 5.5V DC power supply. The EV kit accepts a differential or single-ended audio input and provides differential outputs for the speaker. The device outputs can be connected directly to a speaker load for filterless applications; however, a filter can be added to ease evaluation.

## Features

- ◆ 2.6V to 5.5V Single-Supply Operation
- ◆ Single-Ended or Differential Audio Input
- ◆ Five Selectable Gains
- ◆ Filterless Operation
- ◆ Optional Class D Output Filters for Ease of Evaluation
- ◆ Low-Power Shutdown Input
- ◆ Fully Assembled and Tested

## Ordering Information

PART	TYPE
MAX98302EVKIT+	EV Kit

+Denotes lead(Pb)-free and RoHS compliant.

## Component List

DESIGNATION	QTY	DESCRIPTION
C1	1	10 $\mu$ F $\pm$ 20%, 10V X7R ceramic capacitor (0805) Murata GRM21BR71A106K
C2	1	0.1 $\mu$ F $\pm$ 10%, 16V X7R ceramic capacitor (0603) Murata GRM188R71C104K
C3, C4, C17, C18	4	1 $\mu$ F $\pm$ 10%, 10V X7R ceramic capacitors (0603) Murata GRM188R61A105K
C5, C6, C20, C21	0	Not Installed, capacitors (0603)
C7–C16	10	0.22 $\mu$ F $\pm$ 10%, 25V X7R ceramic capacitors (0603) Murata GRM188R71E224K
FB1–FB4	4	0 $\Omega$ $\pm$ 5% resistors (0603)
JU1, JU4	2	2-pin headers

DESIGNATION	QTY	DESCRIPTION
JU2	1	3-pin header
JU3	1	5-pin header
L1–L4	0	Not installed, 22 $\mu$ H $\pm$ 20%, 1.29A inductors TOKO A916CY-220M (provided with EV kit)
OUTL+, OUTR+	2	Red multipurpose test points
OUTL-, OUTR-	2	White multipurpose test points
R1, R2	2	100k $\Omega$ $\pm$ 5% resistors (0603)
R3, R4, R7, R8	4	22 $\Omega$ $\pm$ 5% resistors (0603)
U1	1	2W Class D amplifier (14 TDFN-EP*) Maxim MAX98302ETD+
—	4	Shunts
—	1	PCB: MAX98302 EVALUATION KIT+

\*EP = Exposed pad.

## Component Suppliers

SUPPLIER	PHONE	WEBSITE
Murata Electronics North America, Inc.	770-436-1300	www.murata-northamerica.com
TOKO America, Inc.	847-297-0070	www.tokoam.com

**Note:** Indicate that you are using the MAX98302 when contacting these component suppliers.



# MAX98302 Evaluation Kit

## Quick Start

### Recommended Equipment

- 2.6V to 5.5V, 2A DC power supply
- Stereo audio input
- Two 8Ω speakers

### Procedure

The MAX98302 EV kit is fully assembled and tested. Follow the steps below to verify board operation.

**Caution: Do not turn on the power supply until all connections are completed.**

- 1) Verify that shunts are installed as follows:
  - JU1, JU4: Installed (single-ended input)
  - JU2: Pins 1-2 (device enabled)
  - JU3: Pins 1-3 (12dB gain)
- 2) Set the power-supply output to 5V. Disable the power supply.
- 3) Connect the power-supply ground terminal to the GND pad and the power-supply positive terminal to the PVDD pad on the EV kit.
- 4) With the audio source disabled, connect the left channel of the audio source to the INL+ test pad.
- 5) Connect the right channel of the audio source to the INR+ test pad.
- 6) Connect the audio source ground to the GND test pad.
- 7) Connect the first speaker across the OUTL+ and OUTL- test points.
- 8) Connect the second speaker across the OUTR+ and OUTR- test points.
- 9) Enable the power-supply output.
- 10) Enable the audio source.
- 11) Verify that the speakers are playing the audio source signal.

## Detailed Description of Hardware

### Filterless Output

The MAX98302 EV kit's filterless outputs (OUTL+, OUTL-, OUTR+, and OUTR-) can be connected directly to a speaker load without any filtering. Use the OUTL+ and OUTL- test points or the OUTR+ and OUTR- test points to connect the speaker directly to the MAX98302 output.

### Filtered Output

Audio analyzers typically cannot accept the Class D amplifier's pulse-width modulated (PWM) signals at their inputs. Therefore, the EV kit features optional lowpass filters at the outputs to ease evaluation. To use the filtering output pads (FOUTL+, FOURL-, FOUTR+, and FOUTR-), install inductors L1–L4 (provided separately with the EV kit), connect the loads to the output pads, and connect the filtered outputs to the audio analyzer. The default lowpass filters at the EV kit output are optimized for an 8Ω speaker.

### Jumper Selection

#### Single-Ended/Differential Audio Inputs

The EV kit features jumpers JU1 and JU4 to select between a differential or single-ended input mode. See Table 1 for shunt positions.

**Table 1. JU1 and JU4 Jumper Selection**

SHUNT POSITION	IN_ PIN	DEVICE OPERATION
Installed*	AC-grounded	Single-ended input
Not installed	AC-coupled to user-supplied negative differential input	Differential input

\*Default position.

# MAX98302 Evaluation Kit

## Shutdown Function ( $\overline{\text{SHDN}}$ )

The EV kit features 3-pin jumper JU2 to control the active-low shutdown input. Drive  $\overline{\text{SHDN}}$  high to place the device in normal operation. Drive  $\overline{\text{SHDN}}$  low to place the device in the low-power shutdown mode. See Table 2 for shunt positions.

**Table 2. JU2 Jumper Selection ( $\overline{\text{SHDN}}$ )**

SHUNT POSITION	$\overline{\text{SHDN}}$ PIN	DEVICE OPERATION
1-2*	Connected to PVDD	Normal operation
2-3	Connected to PGND	Shutdown mode

\*Default position.

## Selectable Gain (GAIN)

The EV kit features 5-pin jumper JU3 to control the MAX98302's five programmable gain settings. See Table 3 for gain control configuration.

**Table 3. JU3 Jumper Selection (GAIN)**

SHUNT POSITION	GAIN PIN	MAXIMUM GAIN (dB)
1-2	Connected to PVDD through 100k $\Omega$ resistor R1	9
1-3*	Connected to PVDD	12
1-4	Connected to PGND through 100k $\Omega$ resistor R2	15
1-5	Connected to PGND	18
Not installed	Unconnected	6

\*Default position.

Evaluates: MAX98302

# MAX98302 Evaluation Kit

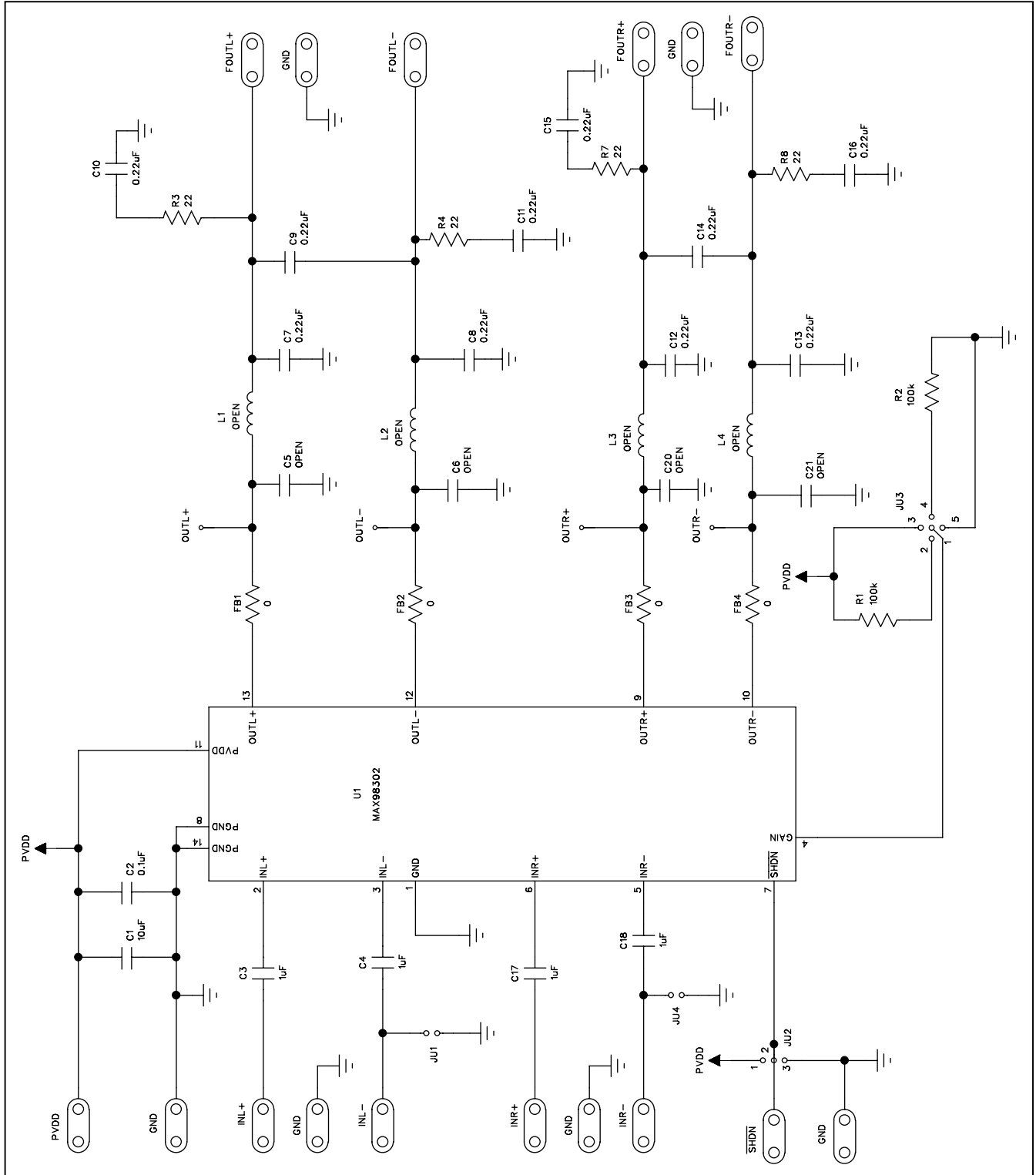

Figure 1. MAX98302 EV Kit Schematic

# MAX98302 Evaluation Kit

Evaluates: **MAX98302**

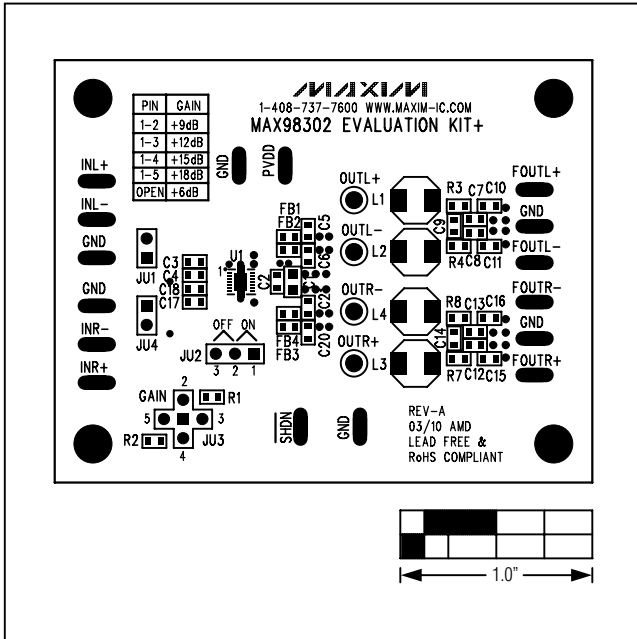

Figure 2. MAX98302 EV Kit Component Placement Guide—Component Side

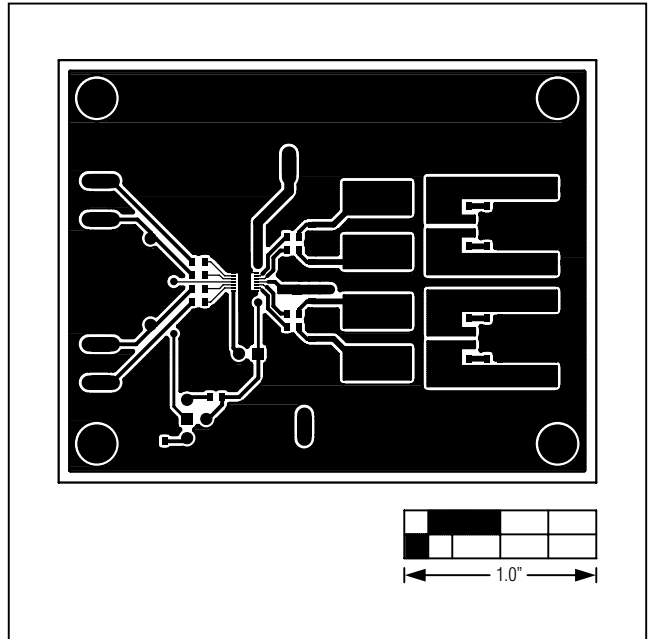

Figure 3. MAX98302 EV Kit PCB Layout—Component Side

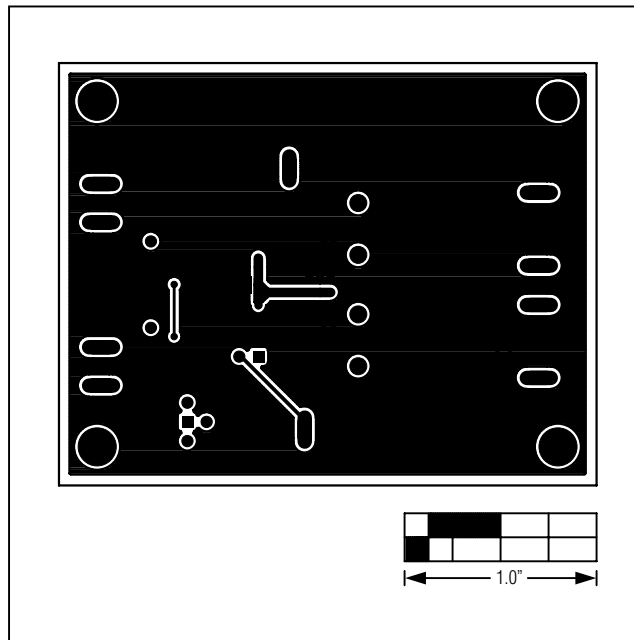

Figure 4. MAX98302 EV Kit PCB Layout—Solder Side

# MAX98302 Evaluation Kit

Evaluates: MAX98302

## Revision History

REVISION NUMBER	REVISION DATE	DESCRIPTION	PAGES CHANGED
0	4/10	Initial release	—

Maxim cannot assume responsibility for use of any circuitry other than circuitry entirely embodied in a Maxim product. No circuit patent licenses are implied. Maxim reserves the right to change the circuitry and specifications without notice at any time.

6 \_\_\_\_\_ Maxim Integrated Products, 120 San Gabriel Drive, Sunnyvale, CA 94086 408-737-7600

© 2010 Maxim Integrated Products

Maxim is a registered trademark of Maxim Integrated Products, Inc.