

NCV7512

FLEXMOS™ Quad Low-Side Pre-Driver

The NCV7512 programmable four channel low-side MOSFET driver is one of a family of FLEXMOS™ automotive grade products used for driving logic-level MOSFETs. The product is controllable by any combination of SPI (Serial Peripheral Interface) or parallel inputs.

Programmable features include optional fault recovery, shorted load detection threshold, fault retry timing, and fault masking mode.

The programmable refresh time allows operation in a power-limiting PWM mode.

The device offers 3.3 V / 5 V compatible logic inputs and the serial output driver can be powered from either 3.3 V or 5 V supplies. Power-on reset of the supply pin provides for a controlled power up and power down. Two enable inputs are supplied. ENA1 provides a global on/off control with a reset function for internal circuitry. ENA2 controls the output stage (during initialization).

Each channel independently monitors its external MOSFET's drain voltage for fault conditions. Shorted load fault detection thresholds are fully programmable using an externally programmed reference voltage and a combination of four discrete internal ratio values. The ratio values are SPI selectable and allow different detection thresholds for each pair of output channels. Open load fault detection threshold is a function of a percentage of the power supply voltage (VCC1). Fault information for each channel is 2-bit encoded by fault type and is available through SPI communication.

The FLEXMOS family of products offers application scalability through choice of external MOSFETs.

Features

- 16-Bit SPI with Frame Error Detection
- 3.3 V/5 V Compatible Parallel and Serial Control Inputs
- 3.3 V/5 V Compatible Serial Output Driver
- Two Enable Inputs
- Open-Drain Fault and Status Flags
- Programmable
 - Shorted Load Fault Detection Thresholds
 - Fault Recovery Mode
 - Fault Retry Timer
 - Flag Masking
- Load Diagnostics with Latched Unique Fault Type Data
 - Shorted Load
 - Open Load
 - Short to GND
- Scalable to Load by Choice of External MOSFET
- These are Pb-Free Devices*
- NCV Prefix for Automotive
 - Site and Change Control
 - AEC-Q100 Qualified

*For additional information on our Pb-Free strategy and soldering details, please download the ON Semiconductor Soldering and Mounting Techniques Reference Manual, SOLDERRM/D.



ON Semiconductor®

<http://onsemi.com>

MARKING DIAGRAM

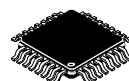

32 LEAD LQFP
FT SUFFIX
CASE 873A

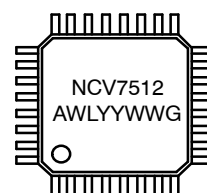

A = Assembly Location
WL = Wafer Lot
YY = Year
WW = Work Week
G = Pb-Free Package

ORDERING INFORMATION

Device	Package	Shipping†
NCV7512FTG	LQFP (Pb-Free)	250 Units/Tray
NCV7512FTR2G	LQFP (Pb-Free)	2000 Tape & Reel

†For information on tape and reel specifications, including part orientation and tape sizes, please refer to our Tape and Reel Packaging Specification Brochure, BRD8011/D.

NCV7512

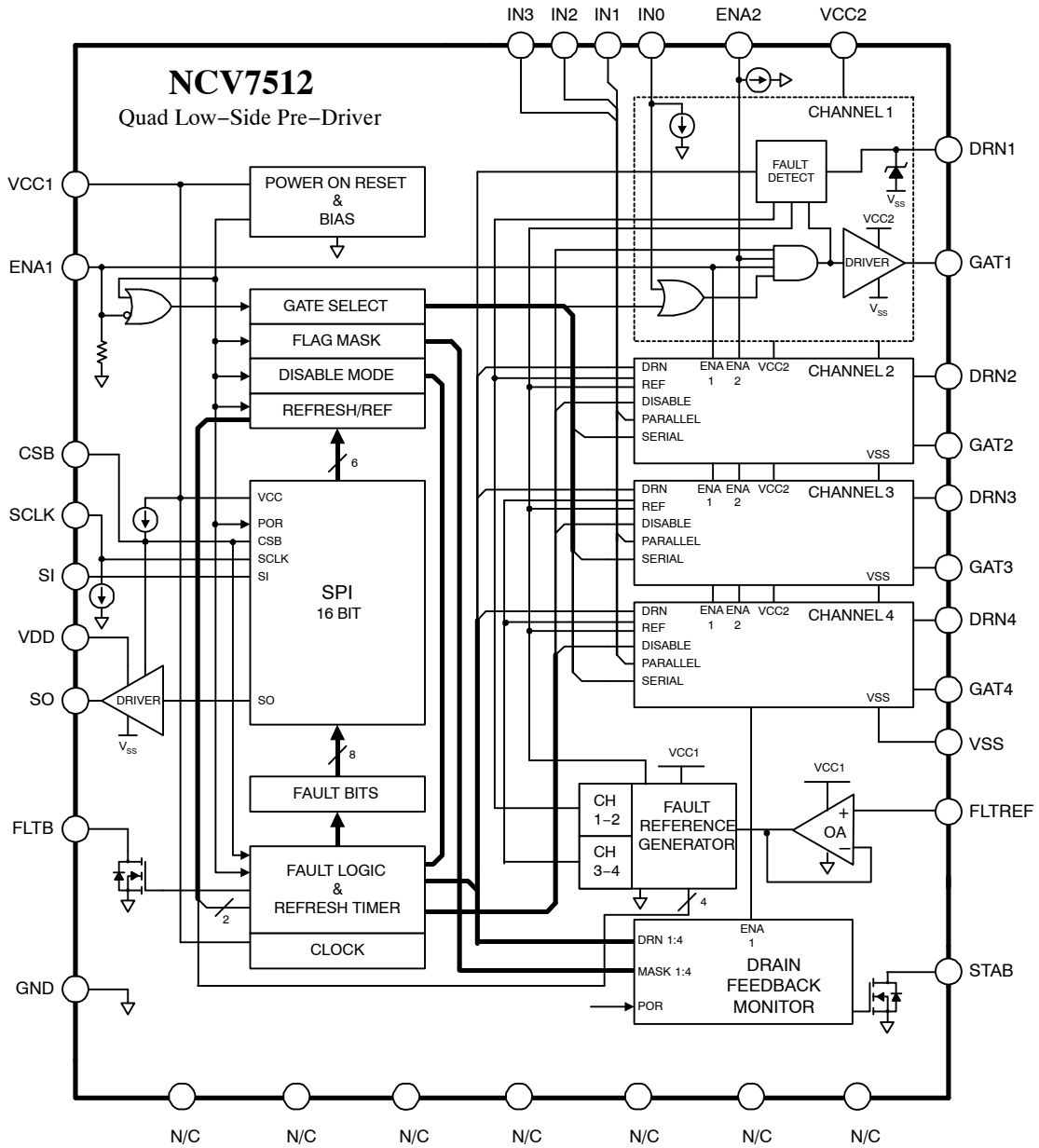

Figure 1. Block Diagram

NCV7512

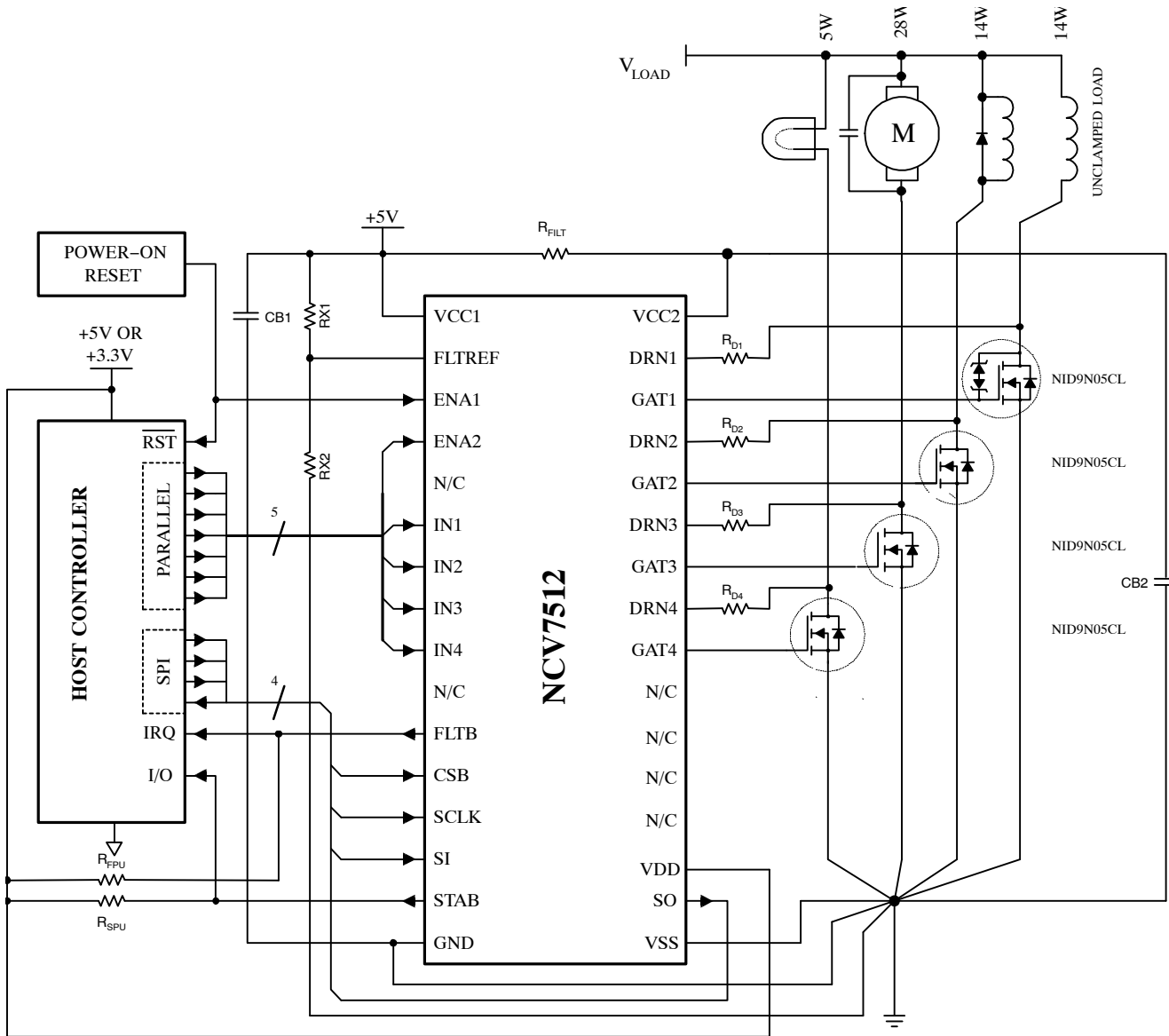

Figure 2. Application Diagram

NCV7512

PIN FUNCTION DESCRIPTION

PIN Number	Symbol	Description
1	N/C*	No Connection.
2	IN1	Channel 1 Input Parallel Control. Active High.
3	IN2	Channel 2 Input Parallel Control. Active High.
4	IN3	Channel 3 Input Parallel Control. Active High.
5	IN4	Channel 4 Input Parallel Control. Active High.
6	N/C*	No Connection.
7	ENA2	Enable 2 Input. Active High. Output Driver Control and Diagnostic Circuitry.
8	ENA1	Enable 1 Input. Active High. Output Driver Control with System Reset.
9	FLTB	Fault Bar Flag. Open–Drain Output. Goes Low with any Channel Open or Short Condition.**
10	CSB	Chip Select Bar (SPI Control).
11	SCLK	Serial Clock (SPI Control).
12	SI	Serial Input (SPI Control).
13	SO	Serial Output (SPI Control).
14	VDD	Power Supply – Serial Output Driver.
15	STAB	Status Bar Flag. Open–Drain Output. Goes Low when any DRNx is Low (FET is On).**
16	VSS	Power Return (Ground) for VCC2, VDD, Drain Clamps. Isolated from GND by a Diode.
17	N/C*	No Connection.
18	N/C*	No Connection.
19	GAT4	Gate Drive.
20	DRN4	Drain Feedback.
21	GAT3	Gate Drive.
22	DRN3	Drain Feedback.
23	GAT2	Gate Drive.
24	DRN2	Drain Feedback.
25	GAT1	Gate Drive.
26	DRN1	Drain Feedback.
27	N/C*	No Connection.
28	N/C*	No Connection.
29	VCC2	Power Supply for Gate Drivers.
30	VCC1	Power Supply. Logic and Low Power Device.
31	FLTREF	Fault Detection Voltage Threshold.
32	GND	Ground. Power Return for VCC1. Includes Device Substrate.

*True no connect. PC board traces allowable.

** Unless masked out.

NCV7512

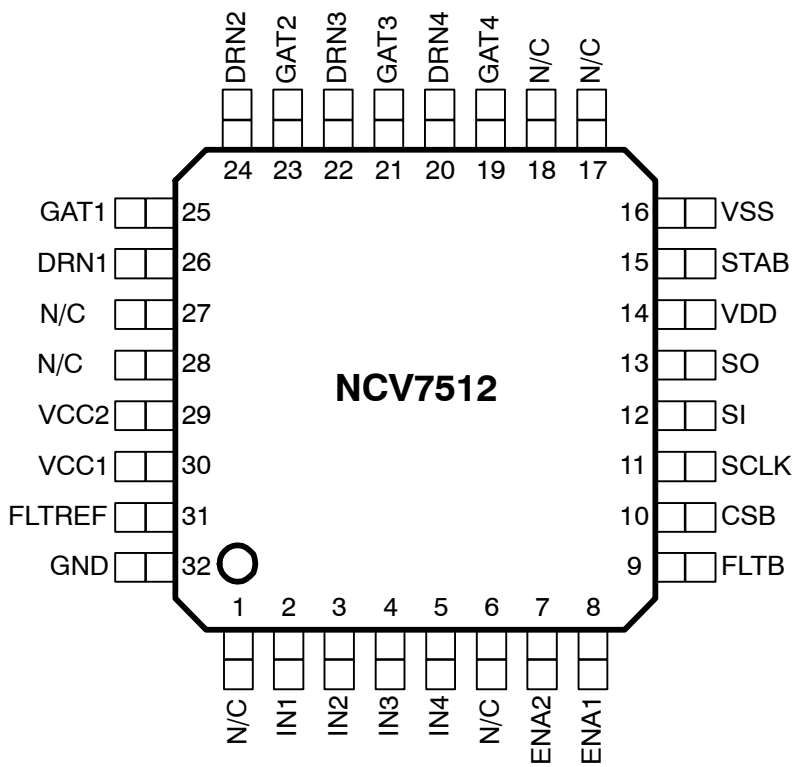

Figure 3. 32 Pin LQFP Pinout (Top View)

NCV7512

MAXIMUM RATINGS (Voltages are with respect to device substrate.)

Rating	Value	Unit
DC Supply (V_{CC1} , V_{CC2} , V_{DD})	-0.3 to 6.5	V
Difference Between V_{CC1} and V_{CC2}	± 0.3	V
Difference Between GND (Substrate) and V_{SS}	± 0.3	V
Output Voltage (GATx, STAB, FLTB, SO)	-0.3 to 6.5	V
Drain Feedback Clamp Voltage (DRNx) (Note 1)	-0.3 to 40	V
Drain Feedback Clamp Current (DRNx) (Note 1)	10	mA
Input Voltage (ENAx, SCLK, SI, FLTREF, Inx)	-0.3 to 6.5	V
Junction Temperature, T_J	-40 to 150	$^{\circ}\text{C}$
Storage Temperature, T_{STG}	-65 to 150	$^{\circ}\text{C}$
Peak Reflow Soldering Temperature: Lead-Free 60 to 150 seconds at 217°C (Note 2)	260 peak	$^{\circ}\text{C}$

Stresses exceeding Maximum Ratings may damage the device. Maximum Ratings are stress ratings only. Functional operation above the Recommended Operating Conditions is not implied. Extended exposure to stresses above the Recommended Operating Conditions may affect device reliability.

1. An external series resistor must be connected between the MOSFET drain and the feedback input in the application. Total clamp power dissipation is limited by the maximum junction temperature, the application environment temperature, and the package thermal resistances.
2. For additional information, see or download ON Semiconductor's Soldering and Mounting Techniques Reference Manual, SOLDERRM/D, and Application Note AND8003/D.
3. Values represent still air steady-state thermal performance on a 4 layer (42 x 42 x 1.5 mm) PCB with 1 oz. copper on an FR4 substrate, using a minimum width signal trace pattern (384 mm² trace area).

RECOMMENDED OPERATING CONDITIONS

Symbol	Parameter	Min	Max	Unit
V_{CC1}	Main Power Supply Voltage	4.75	5.25	V
V_{CC2}	Gate Drivers Power Supply Voltage	$V_{CC1} - 0.3$	$V_{CC1} + 0.3$	V
V_{DD}	Serial Output Driver Power Supply Voltage	3.0	V_{CC1}	V
V_{IN} High	Logic Input High Voltage	2.0	V_{CC1}	V
V_{IN} Low	Logic Input Low Voltage	0	0.8	V
T_A	Ambient Still-Air Operating Temperature	-40	125	$^{\circ}\text{C}$

ATTRIBUTES

Characteristic	Value
ESD Capability Human Body Model Machine Model	$\geq \pm 2.0$ kV $\geq \pm 200$ V
Moisture Sensitivity (Note 2)	MSL3
Package Thermal Resistance (Note 3) Junction-to-Ambient, $R_{\theta JA}$ Junction-to-Pin, $R_{\psi JL}$	86.0 $^{\circ}\text{C}/\text{W}$ 58.5 $^{\circ}\text{C}/\text{W}$

NCV7512

ELECTRICAL CHARACTERISTICS (4.75 V ≤ V_{CCX} ≤ 5.25 V, V_{DD} = V_{CCX}, -40°C ≤ T_J ≤ 125°C, unless otherwise specified.) (Note 4)

Characteristic	Conditions	Min	Typ	Max	Unit
V_{CC1} Supply					
Operating Current	V _{CC1} = 5.25 V, V _{FLTRF} = 1.0 V EN _A _X = 0 EN _A ₁ = EN _A ₂ = V _{CC1} , V _{DRNX} = 0 V, GAT _X drivers off	–	–2.3	5.0	mA
	EN _A ₁ = EN _A ₂ = V _{CC1} , GAT _X drivers on	–	–2.5	5.0	
		–	–2.0	5.0	
Power-On Reset Threshold	V _{CC1} Rising	3.65	4.20	4.60	V
Power-On Reset Hysteresis	–	0.150	0.385	–	V

Digital I/O

V _{IN} High	EN _A _X , IN _X , SI, SCLK, CSB	2.0	–	–	V
V _{IN} Low	EN _A _X , IN _X , SI, SCLK, CSB	–	–	0.8	V
V _{IN} Hysteresis	EN _A _X , IN _X , SI, SCLK, CSB	100	330	500	mV
Input Pullup Current	CSB V _{IN} = 0 V	–25	–10	–	μA
Input Pulldown Current	EN _A ₂ , IN _X , SI, SCLK, V _{IN} = V _{CC1}	–	10	25	μA
Input Pulldown Resistance	EN _A ₁	100	150	200	kΩ
SO Low Voltage	V _{DD} = 3.3 V, I _{SINK} = 5 mA	–	0.11	0.25	V
SO High Voltage	V _{DD} = 3.3 V, I _{SOURCE} = 5 mA	V _{DD} – 0.25	V _{DD} – 0.11	–	V
SO Output Resistance	Output High or Low	–	22	–	Ω
SO Tri-State Leakage Current	CSB = 3.3 V	–10	–	10	μA
STAB Low Voltage	STAB Active, I _{STAB} = 1.25 mA	–	0.1	0.25	V
STAB Leakage Current	V _{STAB} = V _{CC1}	–	–	10	μA
FLTB Low Voltage	FLTB Active, I _{FLTB} = 1.25 mA	–	0.1	0.25	V
FLTB Leakage Current	V _{FLTB} = V _{CC1}	–	–	10	μA

Fault Detection – GAT_X ON

FLTRF Input Current	V _{FLTRF} = 0 V	–1.0	–	–	μA
FLTRF Input Linear Range	Guaranteed by Design	0	–	V _{CC1} – 2.0	V
FLTRF Op-amp V _{CC1} PSRR	Guaranteed by Design	30	–	–	dB
DRN _X Clamp Voltage	I _{DRNX} = 10 μA I _{DRNX} = I _{CL(MAX)} = 10 mA	27 –	32 33.6	– 37	V
DRN _X Shorted Load Threshold	GAT _X Output High, V _{FLTRF} = 1.0 V Register 2: R ₁ = 0, R ₀ = 0 or R ₄ = 0, R ₃ = 0	20	25	30	% V _{FLTRF}
	GAT _X Output High, V _{FLTRF} = 1.0 V Register 2: R ₁ = 0, R ₀ = 1 or R ₄ = 0, R ₃ = 1	45	50	55	% V _{FLTRF}
	GAT _X Output High, V _{FLTRF} = 1.0 V Register 2: R ₁ = 1, R ₀ = 0 or R ₄ = 1, R ₃ = 0	70	75	80	% V _{FLTRF}
	GAT _X Output High, V _{FLTRF} = 1.0 V Register 2: R ₁ = 1, R ₀ = 1 or R ₄ = 1, R ₃ = 1	95	100	105	% V _{FLTRF}
DRN _X Input Leakage Current	V _{CC1} = V _{CC2} = V _{DD} = 5.0 V, EN _A _X = IN _X = 0 V, V _{DRNX} = V _{CL(MIN)} V _{CC1} = V _{CC2} = V _{DD} = 0 V, EN _A _X = IN _X = 0 V, V _{DRNX} = V _{CL(MIN)}	–1.0	–	1.0	μA

4. Designed to meet these characteristics over the stated voltage and temperature recommended operating ranges, though may not be 100% parametrically tested in production.
5. Guaranteed by design.

NCV7512

ELECTRICAL CHARACTERISTICS (continued) ($4.75\text{ V} \leq V_{CCX} \leq 5.25\text{ V}$, $V_{DD} = V_{CCX}$, $-40^{\circ}\text{C} \leq T_J \leq 125^{\circ}\text{C}$, unless otherwise specified.) (Note 4)

Characteristic	Symbol	Conditions	Min	Typ	Max	Unit
Fault Detection – GAT_X OFF						
DRN _X Diagnostic Current	I _{SG}	Short to GND Detection, V _{DRNX} = 0.30 V _{CC1}	-27	-20	-10	μA
	I _{OL}	Open Load Detection, V _{DRNX} = 0.75 V _{CC1}	30	60	80	μA
DRN _X Fault Threshold Voltage	V _{SG}	Short to GND Detection	27	30	33	%V _{CC1}
	V _{OL}	Open Load Detection	72	75	78	%V _{CC1}
DRN _X Off State Bias Voltage	V _{CTR}	-	-	50	-	%V _{CC1}

Gate Driver Outputs

GAT _X Output Resistance		Output High or Low	1.0	1.80	2.5	kΩ
GAT _X High Output Current		V _{GATX} = 0 V	-5.25	-	-1.9	mA
GAT _X Low Output Current		V _{GATX} = V _{CC2}	1.9	-	5.25	mA
Turn-On Propagation Delay	t _{P(ON)}	IN _X to GAT _X (Figure 4)	-	-	1.0	μs
		CSB to GAT _X (Figure 5)				
Turn-Off Propagation Delay	t _{P(OFF)}	IN _X to GAT _X (Figure 4)	-	-	1.0	μs
		CSB to GAT _X (Figure 5)				
Output Rise Time	t _R	20% to 80% of V _{CC2} , C _{LOAD} = 400 pF (Figure 4, Note 5)	-	-	1.40	μs
Output Fall Time	t _F	80% to 20% of V _{CC2} , C _{LOAD} = 400 pF (Figure 4, Note 5)	-	-	1.40	μs

Fault Timers

Channel Fault Blanking Timer	t _{BL(ON)}	V _{DRNX} = 5.0 V; IN _X rising to FLT _B falling (Figure 6)	30	45	60	μs
	t _{BL(OFF)}	V _{DRNX} = 0 V; IN _X falling to FLT _B falling (Figure 6)	90	120	150	μs
Channel Fault Filter Timer	t _{FF}	Figure 7	7.0	12	17	μs
Global Fault Refresh Timer (Auto-retry Mode)	t _{FR}	Register 2: Bit R ₂ = 0 or R ₅ = 0	7.5	10	12.5	ms
		Register 2: Bit R ₂ = 1 or R ₅ = 1	30	40	50	ms
Timer Clock		ENA1 = High	-	500	-	kHz

Serial Peripheral Interface (Figure 9) V_{CCX} = 5.0 V, V_{DD} = 3.3 V, F_{SCLK} = 4.0 MHz, C_{LOAD} = 200 pF

SO Supply Voltage	V _{DD}	3.3 V Interface	3.0	3.3	3.6	V
		5 V Interface	4.5	5.0	5.5	V
SCLK Clock Period		-	-	250	-	ns
Maximum Input Capacitance		SI, SCLK (Note 5)	-	-	25	pF
SCLK High Time		SCLK = 2.0 V to 2.0 V	125	-	-	ns
SCLK Low Time		SCLK = 0.8 V to 0.8 V	125	-	-	ns
SI Setup Time		SI = 0.8 V/2.0 V to SCLK = 2.0 V (Note 5)	25	-	-	ns
SI Hold Time		SCLK = 2.0 V to SI = 0.8 V/2.0 V (Note 5)	25	-	-	ns

NCV7512

ELECTRICAL CHARACTERISTICS (continued) ($4.75\text{ V} \leq V_{CCX} \leq 5.25\text{ V}$, $V_{DD} = V_{CCX}$, $-40^{\circ}\text{C} \leq T_J \leq 125^{\circ}\text{C}$, unless otherwise specified.) (Note 4)

Characteristic	Symbol	Conditions	Min	Typ	Max	Unit
Serial Peripheral Interface (continued) (Figure 9) $V_{CCX} = 5.0\text{ V}$, $V_{DD} = 3.3\text{ V}$, $F_{SCLK} = 4.0\text{ MHz}$, $C_{LOAD} = 200\text{ pF}$						
SO Rise Time		(20% V_{SO} to 80% V_{DD}) $C_{LOAD} = 200\text{ pF}$ (Note 5)	–	25	50	ns
SO Fall Time		(80% V_{SO} to 20% V_{DD}) $C_{LOAD} = 200\text{ pF}$ (Note 5)	–	–	50	ns
CSB Setup Time		CSB = 0.8 V to SCLK = 2.0 V (Note 5)	60	–	–	ns
CSB Hold Time		SCLK = 0.8 V to CSB = 2.0 V (Note 5)	75	–	–	ns
CSB to SO Time		CSB = 0.8 V to SO Data Valid (Note 5)	–	65	125	ns
SO Delay Time		SCLK = 0.8 V to SO Data Valid (Note 5)	–	65	125	ns
Transfer Delay Time		CSB Rising Edge to Next Falling Edge (Note 5)	1.0	–	–	μs

NCV7512

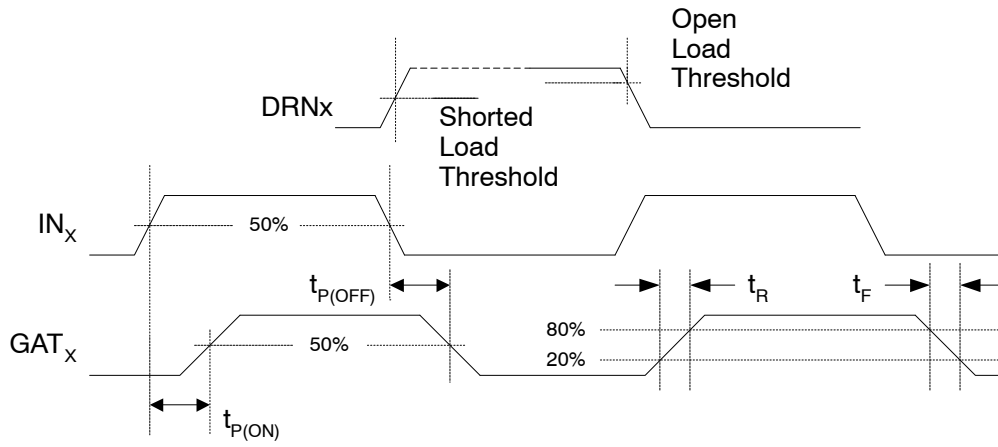

Figure 4. Gate Driver Timing Diagram – Parallel Input

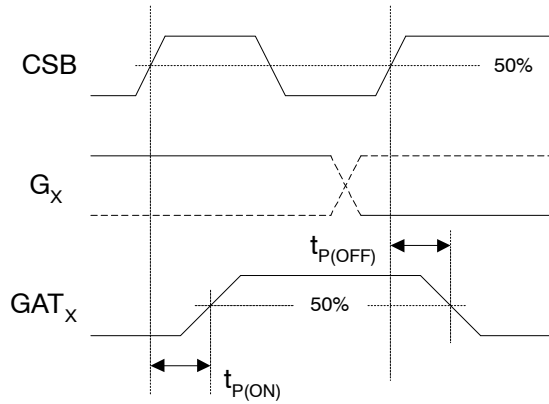

Figure 5. Gate Driver Timing Diagram – Serial Input

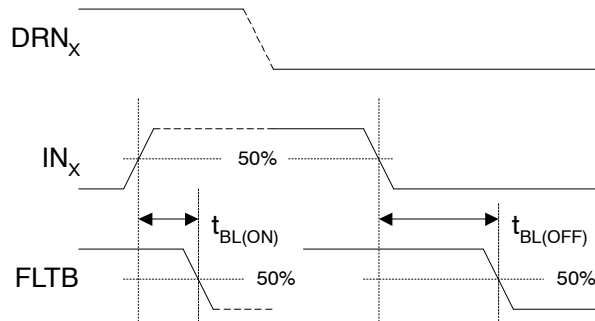

Figure 6. Blanking Timing Diagram

NCV7512

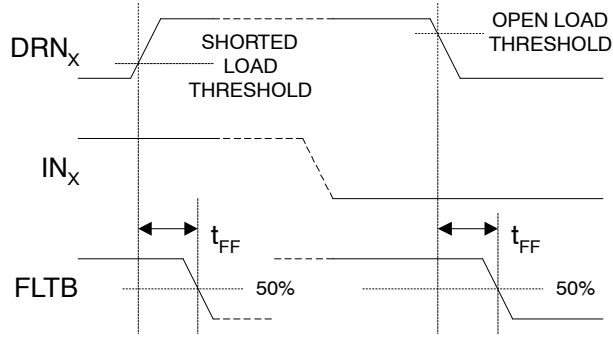

Figure 7. Filter Timing Diagram

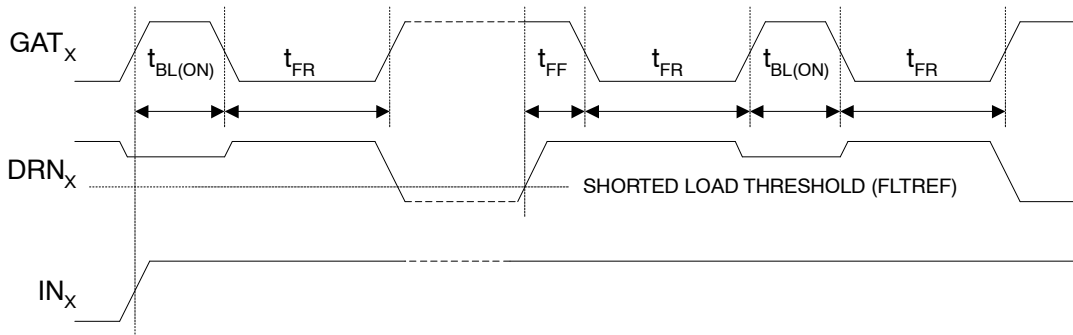
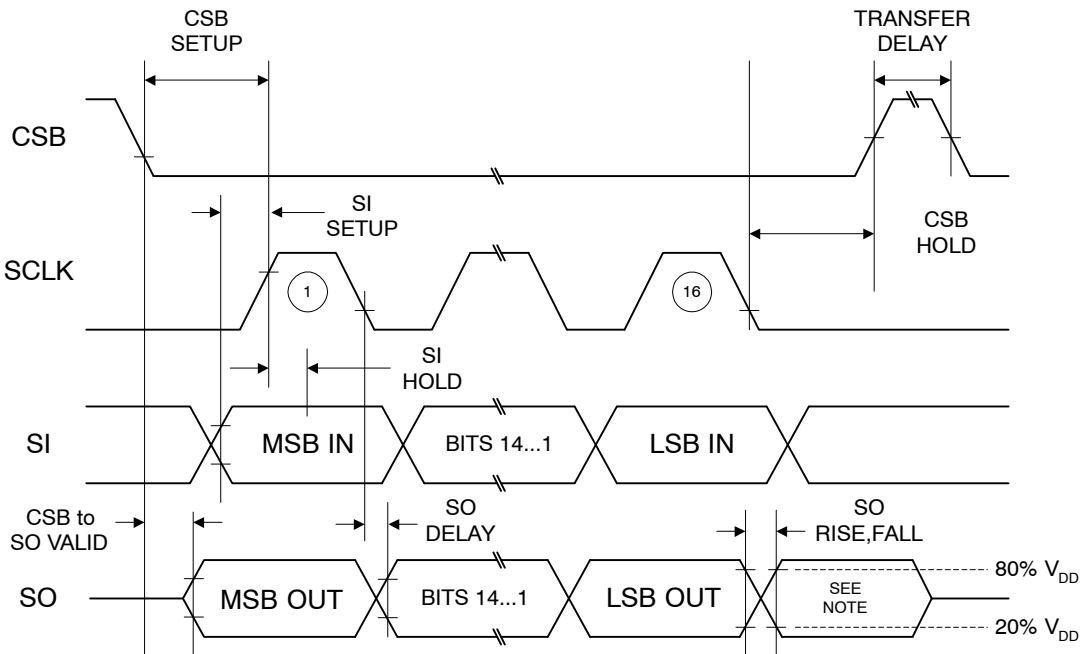

Figure 8. Fault Refresh Timing Diagram



Note: Not defined but usually MSB of data just received.

Figure 9. SPI Timing Diagram

DETAILED OPERATING DESCRIPTION

General

The NCV7512 is a four channel general-purpose low-side pre-driver for controlling and protecting N-type logic level MOSFETs. While specifically designed for driving MOSFETs with resistive, inductive or lamp loads in automotive applications, the device is also suitable for industrial and commercial applications. Programmable fault detection and protection modes allow the NCV7512 to accommodate a wide range of external MOSFETs and loads providing the user with flexible application solutions. Separate power supply pins are provided for low and high current paths to improve analog accuracy and digital signal integrity. ON Semiconductor’s SmartDiscretes™ such as the NID9N05CL, clamp MOSFETs, and are recommended when driving unclamped inductive loads.

Power Up/Down Control

The NCV7512’s power-up/down control prevents spurious output operation by monitoring the V_{CC1} power supply voltage. An internal Power-On Reset (POR) circuit holds all GAT_X outputs low until sufficient voltage is available to allow proper control of the device. All internal registers are initialized to their default states, fault data is cleared, and the open-drain fault (FLT_B) and status flags (STAB) are disabled during a POR event.

When V_{CC1} exceeds the POR threshold, the device is ready to accept input data, outputs are allowed to turn on, and fault and status reporting are accurate. When V_{CC1} falls below the POR threshold during power down, fault flags are reset and reporting is disabled. All GAT_X outputs are held low. Operation below V_{CC1}=0.7V is not specified.

SPI Communication

The NCV7512 is a 16-bit SPI slave device. SPI communication between the host and the NCV7512 may either be directly addressed through CSB or daisy-chained through other devices using a compatible SPI protocol.

The active-low CSB chip select bar input has a pull-up current source. The SI and SCLK inputs have pull-down current sources. The recommended idle state for SCLK is low. The tri-state SO line driver can operate in 3.3V or 5V systems. Power (3.3V or 5V) to the SO driver is applied via the device’s V_{DD} and V_{SS} pins.

The NCV7512 employs frame error detection. Integer multiples of 16 SCLK cycles during each CSB high-low-high cycle (valid communication frame) is required for the device to recognize a command. A frame error does not affect error flag reporting.

The CSB input controls SPI data transfer and initializes the selected device’s frame error and fault reporting logic.

The host initiates communication when a selected device’s CSB pin goes low. The master’s SCLK signal shifts Output (fault) data MSB first from the SO pin while input (command) data is received MSB first at the SI pin (Figure 10).

Fault data changes on the falling edge of SCLK and is guaranteed valid before the next rising edge of SCLK. Command data received must be valid before the rising edge of SCLK.

When CSB goes low, frame error detection is initialized, latched fault data is transferred to the SPI, and the FLT_B flag is disabled and reset if previously set. Faults while CSB is low are ignored, but will be captured if still present after CSB goes high.

If a valid frame has been received when CSB goes high, the last multiple of 16 bits received is decoded into command data, and FLT_B is re-enabled. Latched (previous) fault data is cleared and current fault data is captured. The FLT_B flag will be set if a fault is detected.

If a frame error is detected when CSB goes high, new command data is ignored, and previous fault data remains latched and available for retrieval during the next valid frame. The FLT_B flag will be set if a fault is detected. Frame errors are ignored. They are not reported by FLT_B.

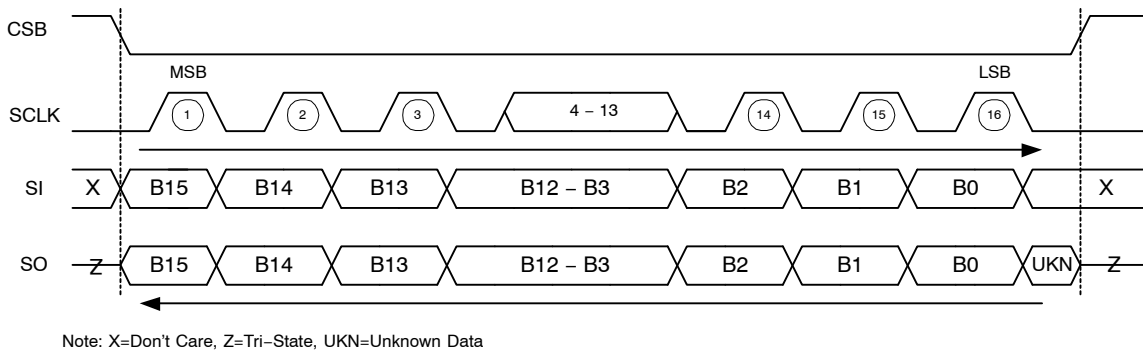

Figure 10. SPI Communications Frame Format

Serial Data and Register Structure

The 16-bit data received (SI) is decoded into a 4-bit address and a 6-bit data word (Figure 11). The upper four bits, beginning with the received MSB, are fully decoded to address one of four programmable registers and the lower six bits are decoded into data for the addressed

register. Bit B15 must always be set to zero. Valid register addresses are shown in Table 1.

The 16-bit data sent (SO) by the NCV7512 is encoded 8-bit fault information. The upper 6 bits are forced to zero and lower 2 bits are forced to zero (Figure 12).

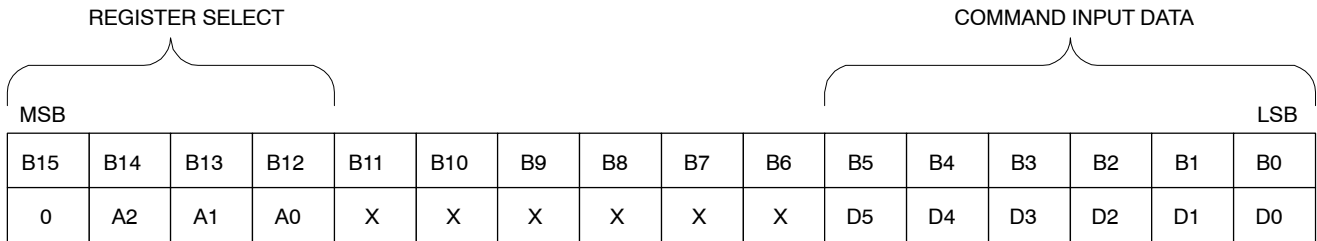

Figure 11. SPI Input Data

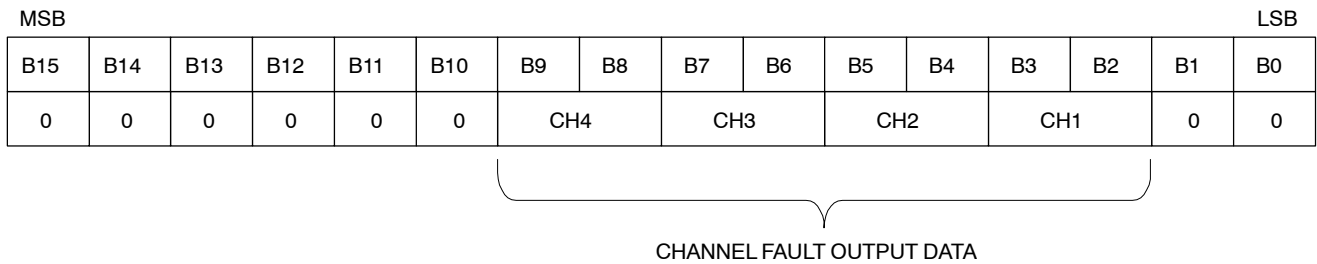

Figure 12. SPI Output Data

Table 1. Register Address Definitions

FUNCTION TABLE

ADDRESS			6-BIT INPUT DATA						
A2	A1	A0	D5	D4	D3	D2	D1	D0	
0	0	0		Gate Select					
0	0	1		Disable Mode					
0	1	0	Refresh & Reference						
0	1	1		Mask					
1	0	0	Null						
			OUTPUT DATA						
X	X	X	8-bit Fault Data						

Gate Select – Register 0

Each GAT_X output is turned on/off by programming its respective G_X bit (Table 2). Setting a bit to 1 causes the selected GAT_X output to drive its external MOSFET’s gate to V_{CC2} (ON.) Setting a bit to 0 causes the selected GAT_X output to drive its external MOSFET’s gate to V_{SS} (OFF.)

Note that the actual state of the output depends on POR, ENA_X and shorted load fault states as later defined by Equation 1. At power-up, each bit is set to 0 (all outputs OFF.)

Table 2. Gate Select Register

A ₂	A ₁	A ₀	D ₅	D ₄	D ₃	D ₂	D ₁	D ₀
0	0	0		G ₄	G ₃	G ₂	G ₁	
			0 = GAT _X OFF 1 = GAT _X ON					

Disable Mode – Register 1

The disable mode for shorted load faults is controlled by each channel’s respective M_X bit (Table 3). Setting a bit to 1 causes the selected GAT_X output to latch-off when a fault is detected. Setting a bit to 0 causes the selected GAT_X output to auto-retry when a fault is detected.

At power-up, each bit is set to 0 (all outputs in auto-retry mode.)

Table 3. Disable Mode Register

A ₂	A ₁	A ₀	D ₅	D ₄	D ₃	D ₂	D ₁	D ₀
0	0	1		M ₄	M ₃	M ₂	M ₁	
			0 = AUTO-RETRY 1 = LATCH OFF					

Refresh and Reference – Register 2

Refresh time (auto-retry mode) and shorted load fault detection references are programmable in two groups of two channels. Refresh time and the fault reference for channels 4–3 is programmed by RX bits 4–3. Refresh time

and the fault reference for channels 2–1 is programmed by RX bits 2–1 (Table 4).

At power-up, each bit is set to 0 (VFLT = 25% VFLTREF, tFR = 10 ms.)

Table 4. Refresh and Reference Register

A ₂	A ₁	A ₀	D ₅	D ₄	D ₃	D ₂	D ₁	D ₀
0	1	0	R ₅	R ₄	R ₃	R ₂	R ₁	R ₀
			CHANNELS 4–3			CHANNELS 2–1		
25% V _{FLTREF}			X	0	0	X	0	0
50% V _{FLTREF}			X	0	1	X	0	1
75% V _{FLTREF}			X	1	0	X	1	0
V _{FLTREF}			X	1	1	X	1	1
t _{FR} = 10 ms			X	X	X	0	X	X
t _{FR} = 40 ms			X	X	X	1	X	X
t _{FR} = 10 ms			0	X	X	X	X	X
t _{FR} = 40 ms			1	X	X	X	X	X

Flag / STAB Mask – Register 3

Using the mask feature, allows the user to disable the FLTB and STAB flag reporting on a channel by channel basis. No allowance is made to segregate control of masking Flag and Status reporting.

The drain feedback from each channel’s DRN_X input is combined with the channel’s K_X mask bit (Table 5.) When K_X=1, a channel’s mask is cleared and its feedback to the FLTB and STAB flags is enabled.

At power-up, each bit is set to 0 (all masks set.)

Table 5. Flag Mask Register

A ₂	A ₁	A ₀	D ₅	D ₄	D ₃	D ₂	D ₁	D ₀
0	1	1		K ₄	K ₃	K ₂	K ₁	
			0 = MASK SET 1 = MASK CLEAR					

The STAB flag is influenced when a mask bit changes CLR→SET after one valid SPI frame. FLTB is influenced after two valid SPI frames. This is correct behavior for FLTB since, while a fault persists, the FLTB will be set when CSB goes LO→HI at the end of a SPI frame. The mask instruction is decoded after CSB goes LO→HI so FLTB will only reflect the mask bit change after the next SPI frame. Both FLTB and STAB require only one valid SPI frame when a mask bit changes SET→CLR.

Null Register – Register 4

The null register (Table 6) provides a way to retrieve fault information without actively changing an input command (i.e. modifying D_X). Fault information is always returned when any register is addressed.

Table 6. Null Register

A ₂	A ₁	A ₀	D ₅	D ₄	D ₃	D ₂	D ₁	D ₀
1	X	X	X	X	X	X	X	X

Gate Driver Control and Enable

Each GAT_X output may be turned on by either its respective parallel IN_X input or SPI control of the internal G_X (Gate Select) register bit.

The device’s common ENA_X enable inputs can be used to implement global control functions, such as system reset, over-voltage or input override by a watchdog controller. Each parallel input (Inx) and the ENA2 input have individual internal pull-down current sources. The ENA1 input has an internal pull-down resistor. Unused parallel inputs should be connected to GND and unused enable inputs should be connected to V_{CC1}.

Input signal frequency of PWM Inx signals should be kept less than 2 kHz.

When ENA1 is brought low, all GAT_X outputs, the timer clock, and the flags are disabled. The fault and gate registers are cleared and the flags are reset. New serial G_X data is ignored while ENA1 is low but other registers can be programmed. ENA1 provides global on/off control and provides a soft reset.

ENA2 disables all GAT_X outputs and diagnostic circuitry when brought low. SPI control and Parallel (Inx) inputs are still recognized when ENA2 is low. ENA2 provides local on/off control and can be used to disable the GAT_X outputs during initialization of the NCV7512. ENA2 can also be used to PWM all outputs simultaneously at low frequencies.

When both the ENA1 and ENA2 inputs are high, the outputs will reflect the current parallel and serial input states. Turning on a channel is an OR'd function of the parallel and serial inputs.

The IN_X input state and the G_X register bit data are logically combined with the internal (active low) power-on reset signal (POR), the ENA_X input states, and the shorted load state (SHRT_X) to control the corresponding GAT_X output such that:

$$GAT_X = POR \cdot ENA1 \cdot ENA2 \cdot \overline{SHRT_X} \cdot (IN_X + G_X) \quad (\text{eq. 1})$$

The GAT_X state truth table is given in Table 7.

Table 7. Gate Driver Truth Table

POR	ENA1	ENA2	SHRT _X	IN _X	G _X	GAT _X
0	X	X	X	X	X	L
1	0	0	X	X	X	L
1	0	1	X	X	X	L
1	1	0	X	X	X	L
1	1	1	1	0	0	L
1	1	1	1	1	X	H
1	1	1	1	X	1	H
1	1	1	0	X	X	L
1	1→0	1	X	X	→0	→L
1	1	1→0	X	X	G _X	→L
1	1	0→1	X	0	G _X	→G _X

Gate Drivers

Each channels non-inverting GAT_X drivers are resistive switches (1.80 kΩ typ.) to V_{CC2} and V_{SS}. On-chip matching of drivers insures equivalent channel capability. Load current switching matching is more dependent on the characteristics of the external MOSFET and load.

Figure 12 shows the gate driver block diagram.

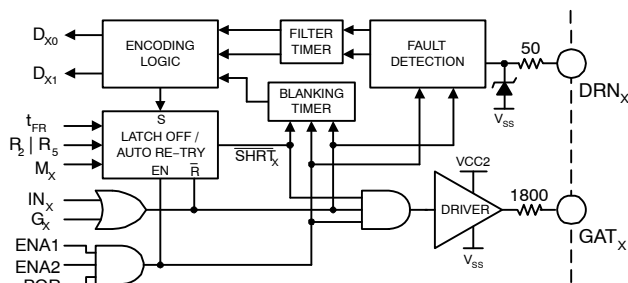

Figure 13. Gate Driver Channel

Fault Diagnostics and Behavior

Each channel has independent fault diagnostics and employs both blanking and filter timers to suppress false faults. An external MOSFET is monitored for fault conditions by connecting its drain to a channel's DRNX feedback input through an external series resistor.

Diagnostics are disabled when ENA1 or ENA2 is low. When both ENA1 and ENA2 are high, diagnostics are enabled.

Shorted load faults are detected when a driver is on. Open load or short to GND faults are detected when a driver is off.

On-state faults will initiate MOSFET protection behavior. The FLTB flag will be set and the respective channel's DX fault bit is latched.

Off-state faults will simply set the FLTB flag and the channel's DX bits.

Fault types are encoded in a 2-bit per channel format. Fault information for all channels is simultaneously retrieved by a SPI read (Figure 11). Table 8 shows the fault-encoding scheme for channel 0. The remaining channels are identically encoded.

Table 8. Fault Data Encoding

CHANNEL 0		STATUS
D ₁	D ₀	
0	0	NO FAULT
0	1	OPEN LOAD
1	0	SHORT TO GND
1	1	SHORTED LOAD

Fault Blanking and Fault Filter Timers

Fault Blanking timers are used to allow drain feedback to stabilize after a channel is commanded to change states. Fault Filter timers are used to suppress glitches while a channel is in a stable state.

A turn-on blanking timer is started when a channel is commanded on. Drain feedback is sampled after t_{BL(ON)}. A turn-off blanking timer is started when a channel is commanded off. Drain feedback is sampled after t_{BL(OFF)}.

Blanking timers for all channels are started when both ENA1 and ENA2 go high or when either ENA_X goes high while the other is high.

A filter timer is started when a channel is in a stable state and a fault detection threshold associated with that state has been crossed. Drain feedback is sampled after t_{FF}.

Each channel has independent blanking and filter timers. The parameters for the t_{BL(ON)}, t_{BL(OFF)}, and t_{FF} times are identical for all channels.

Shorted Load Detection

An external reference voltage (applied to the FLTREF input) serves as a common reference for all channels (Figure 13) in detecting shorted load conditions. The FLTREF voltage must be within the range of 0 to V_{CC1}-2.0V. The part is designed to be used with a voltage divider between V_{CC1} and GND.

Shorted load detection thresholds can be programmed via the SPI port in four 25% increments that are ratiometric

to the applied FLTREF voltage. Separate thresholds can be selected for channels 1–2 and for channels 3–4 (Table 4).

A shorted load fault is detected when a channel's DRN_X feedback is greater than its programmed fault reference (after the turn-on blanking or the fault filter has timed out).

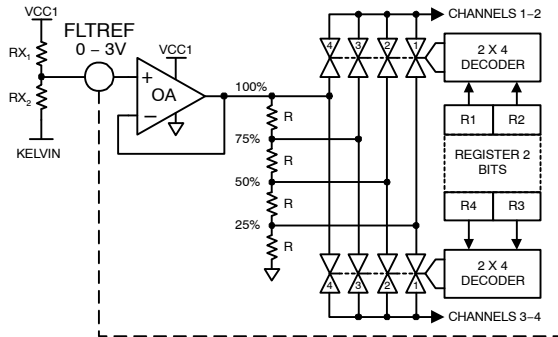

Figure 14. Shorted Load Reference Generator

Shorted Load Fault Recovery

Each channel is SPI programmable for shorted load response. The M_X bits in the device's Disable Mode register (Table 3) control the channels to latch-off during a fault or auto-retry.

When latch-off mode is selected the corresponding GAT_X output is turned off upon detection of a fault. Fault recovery is initiated by toggling (ON→OFF→ON) the channel's respective IN_X parallel input, serial G_X bit, or ENA2.

When auto-retry mode is selected (default mode) the corresponding GAT_X output is turned off for the duration of the programmed fault refresh time (t_{FR}) upon detection of a fault. The output is automatically turned back on (if still commanded on) when the refresh time ends. The channel's DRN_X feedback is re-sampled after the turn-on blanking time. The output will automatically turn off if a fault is again detected. This behavior will continue for as long as the channel is commanded on and the fault persists.

In either mode, a fault may exist at turn-on or may occur some time afterward. To be detected, the fault must exist longer than either the channel fault blanking timer (t_{BL(ON)}) at turn-on or longer than the channel fault filter timer (t_{FF}) some time after turn-on. The length of time that a MOSFET stays on during a shorted load fault is thus limited to either t_{BL(ON)} or t_{FF}.

In auto-retry mode, a persistent shorted load fault will result in a low duty cycle (t_{FD} ≈ t_{BL(ON)}/t_{FR}) for the affected channel and help prevent thermal failure of the channel's MOSFET.

CAUTION – CONTINUOUS INPUT TOGGING VIA IN_X, G_X or ENA2 WILL OVERRIDE EITHER DISABLE MODE. Care should be taken to service a shorted load fault quickly.

Fault Recovery Refresh Time

Refresh time for shorted load faults is SPI programmable to one of two values (10ms or 40ms) for channels 1–2 (register bit R2) and for channels 3–4 (register bit R5) via the Refresh and Reference register (Table 4).

A global refresh timer is used for auto-retry timing. The first faulted channel triggers the timer and the full refresh period is guaranteed for that channel. An additional faulted channel may initially retry immediately after its turn-on blanking time, but subsequent retries will have the full refresh time period.

If all channels in a group (e.g. channels 1–2) become faulted, they will become synchronized to the selected refresh period for that group. If all channels become faulted and are set for the same refresh time, all will become synchronized to the refresh period.

Open Load and Short to GND Detection

A window comparator with fixed references proportional to V_{CC1} along with a pair of bias currents is used to detect open load or short to GND faults when a channel is off. Each channel's DRN_X feedback is compared to the references after either the turn-off blanking or the filter has timed out. Figure 14 shows the DRN_X fault detection zones. Note, the diagnostics are disabled and the bias currents are turned off when ENA_X is low.

No fault is detected if the feedback voltage at DRN_X is greater than the V_{OL} open load reference. If the feedback is less than the V_{SG} short to GND reference, a short to GND fault is detected. If the feedback is less than V_{OL} and greater than V_{SG}, an open load fault is detected.

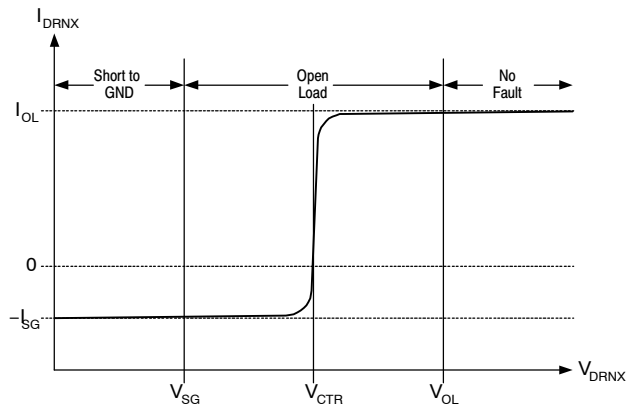

Figure 15. DRN_X Bias and Fault Detection Zones

Figure 16 shows the simplified detection circuitry. Bias currents I_{SG} and I_{OL} are applied to a bridge along with bias voltage V_{CTR} (50% V_{CC1} typ.).

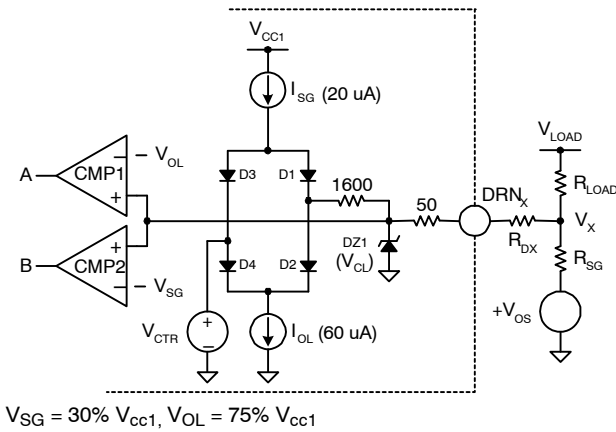

Figure 16. Short to GND/Open-Load Detection

Normal Operation – When a channel is off and V_{LOAD} and R_{LOAD} are present, R_{SG} (short to ground) is absent, and $V_{DRNX} \gg V_{CTR}$, bias current I_{OL} (open load) is supplied from V_{LOAD} to ground through external resistors R_{LOAD} and R_{DX} , and through the internal 1650Ω resistance and bridge diode D2. Bias current I_{SG} is supplied from V_{CC1} to V_{CTR} through D3. No fault is detected if the feedback voltage (V_{LOAD} minus the total voltage drop caused by I_{SG} and the resistance in the path) on CMP1 is greater than V_{OL} (and the voltage on CMP2 is greater than V_{SG} [it will be since R_{SG} is absent]).

Open Fault – When either V_{LOAD} or R_{LOAD} , and R_{SG} are absent, the bridge will self-bias so that the voltage at $DRNX$ will settle to about V_{CTR} . An open load fault will be detected since the feedback voltage to CMP1 and CMP2 is between V_{SG} and V_{OL} .

Short to GND – Detection can tolerate an offset (V_{OS}) between the NCV7512's GND and the short. The value of the functional offset is determined by the R_{DX} resistor value and the user defined acceptable threshold shift. When R_{SG} is present and $V_{DRNX} \ll V_{CTR}$, bias current I_{SG} is supplied from V_{CC1} to V_{OS} through D1, the internal 1650Ω , and the external R_{DX} and R_{SG} resistances. Bias current I_{OL} is supplied from V_{CTR} to ground through D4.

A “weak” short to GND can be detected when either V_{LOAD} or R_{LOAD} is absent and the feedback (V_{OS} plus the total voltage rise caused by I_{OL} and the resistance in the path) is less than V_{OL} . The NCV7512 does not distinguish between “weak” shorts and “hard” shorts.

When V_{LOAD} and R_{LOAD} are present, a voltage divider between V_{LOAD} and V_{OS} is formed by R_{LOAD} and R_{SG} . A “hard” short to GND may be detected in this case depending on the ratio of R_{LOAD} and R_{SG} and the values of R_{DX} , V_{LOAD} , and V_{OS} .

Note that the comparators see a voltage drop or rise due only to the 50Ω internal resistance and the bias currents. This produces a small difference in the comparison to the actual feedback voltage at the $DRNX$ input.

Several equations for choosing R_{DX} and for predicting open load or short to GND resistances, and a discussion of

the dynamic behavior of the short to GND/ open load diagnostic are provided in the Applications Information section of this data sheet.

Status Flag (STAB)

The open-drain active-low status flag output reports the state of the channels $DRNX$ feedback. Feedback from all channels is logically OR'd to the flag (Figure 16). STAB goes low when any $DRNX$ is low. STAB does not report masked channels. The STAB outputs from several devices can be wire-OR'd to a common pull-up resistor connected to the controller's 3.3 or 5 V V_{DD} supply.

When ENA1 is high, the drain feedback from a channel's $DRNX$ input is compared to the V_{OL} reference and reported without regard to ENA2 or the commanded state of the channel's driver. The status flag is reset and disabled when ENA1 is low or when all mask bits are set. See Table 9 for additional details.

The status flag is set (low) when the feedback voltage is less than V_{OL} , and the channel's mask bit (Table 5) is cleared. The flag is reset (hi-Z) when the feedback voltage is greater than V_{OL} , and the channel's mask bit is cleared.

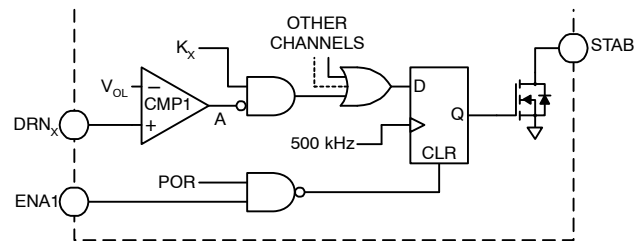

Figure 17. STAB Flag Logic

Fault Flag (FLTb)

The open-drain active-low fault flag output can be used to provide immediate fault notification to a host controller. Fault detection from all channels is logically ORed to the flag (Figure 17). The FLTb outputs from several devices can be wire-ORed to a common pull-up resistor connected to the controller's 3.3 or 5 V V_{DD} supply.

The flag is set (low) when a channel detects any fault, the channel's mask bit (Table 5) is cleared, and both ENA_x and CSB are high. The Fault Flag is reset (hi-Z) and disabled when either ENA1 or CSB is low. See Table 9 for additional details.

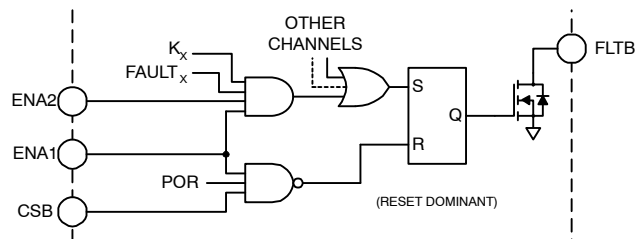

Figure 18. FLTb Flag Logic

Fault Detection and Capture

Each channel of the NCV7512 is capable of detecting shorted load faults when the channel is on, and short to ground or open load faults when the channel is off.

Each fault type is uniquely encoded into two-bit per channel fault data. A drain feedback input for each channel compares the voltage at the drain of the channel's external MOSFET to several internal reference voltages. Separate detection references are used to distinguish the three fault types and blanking and filter timers are used respectively to allow for output state transition settling and for glitch suppression.

Fault diagnostics are disabled when either enable input is low. When both enable inputs are high, each channel's drain feedback input is continuously compared to references appropriate to the channel's input state to detect faults, but the comparison result is only latched at the end of either a blanking or filter timer event.

Blanking timers for all channels are triggered when either ENx input changes state from low to high while the other enable input is high, or when both enable inputs go high simultaneously. A single channel's blanking timer is triggered when its input state changes. If the comparison of the feedback to a reference indicates an abnormal condition when the blanking time ends, a fault has been detected and the fault data is latched into the channel's fault latch.

A channel's filter timer is triggered when its drain feedback comparison state changes. If the change indicates an abnormal condition when the filter time ends, a fault has been detected and the fault data is latched into the channel's fault latch.

Thus, a state change of the inputs (ENx, INx or Gx) or a state change of an individual channel's feedback (DRNx) comparison must occur for a timer to be triggered and a detected fault to be captured.

Fault Capture, SPI Communication, and SPI Frame Error Detection

The fault capture and frame error detection strategies of the NCV7512 combine to ensure that intermittent faults

can be captured and identified, and that the device cannot be inadvertently re-programmed by a communication error.

The NCV7512 latches a fault when it is detected, and frame error detection will not allow any register to accept data if an invalid frame occurred.

When a fault has been detected, the FLTB flag is set and fault data is latched into a channel's fault latch. The latch captures and holds the fault data and ignores subsequent fault data for that channel until a valid SPI frame occurs.

Fault data from all channels is transferred from each channel's fault latch into the SPI shift register and the FLTB flag is reset when CSB goes low at the start of the SPI frame. Fault latches are cleared and re-armed when CSB goes high at the end of the SPI frame only if a valid frame has occurred; otherwise the latches retain the detected fault data until a valid frame occurs. The FLTB flag will be set if a fault is still present.

Fault latches for all channels and the FLTB flag can also be cleared and re-armed by toggling ENA1 H-L-H. A full I/O truth table is given in Table 9.

Fault Data Readback Examples

Several examples are shown to illustrate fault detection, capture and SPI read-back of fault data for one channel. A normal SPI frame returns 16 bits of data but only the two bits of serial data for the single channel are shown for clarity.

The examples assume:

The NCV7512 is configured as in Figure 2;

Both enable inputs are high;

The channel's flag mask bit is cleared ;

Disable mode is set to auto-retry;

The parallel input commands the channel;

SPI frame is always valid.

Shorted Load Detected

Refer to Figure 18. The channel is commanded on when IN_X goes high. GAT_X goes high and the timers are started. At “A”, the STAB flag is set as the DRN_X feedback falls through the V_{OL} threshold.

A SPI frame sent soon after the IN_X command returns data indicating “no fault”.

The blanking time ends, and the filter timer is triggered as DRN_X rises (a shorted load fault occurs) through the $FLTREF$ threshold. The STAB flag is reset as DRN_X passes through the V_{OL} threshold. DRN_X is nearly at V_{LOAD} when the filter time ends at “B”. A shorted load fault is detected and captured by the fault latch, GAT_X goes low, the FLT B flag is set, and the auto-retry timer is started.

A SPI frame sent soon after “B” returns data indicating “shorted load”.

The FLT B flag is reset when CSB goes low (“F”). At “C” when CSB goes high at the end of the frame, the fault latch is cleared and re-armed. Since IN_X and the DRN_X feedback are unchanged, FLT B and the fault latch are set and the fault is re-captured (“G”).

When the auto-retry timer ends at “D”, GAT_X goes high and the blanking and filter timers are started. Since IN_X and DRN_X are unchanged, GAT_X goes low when the blanking time ends at “E” and the auto-retry timer is started. Read-back data continues to indicate a “shorted load” and the FLT B flag continues to be set while the fault persists.

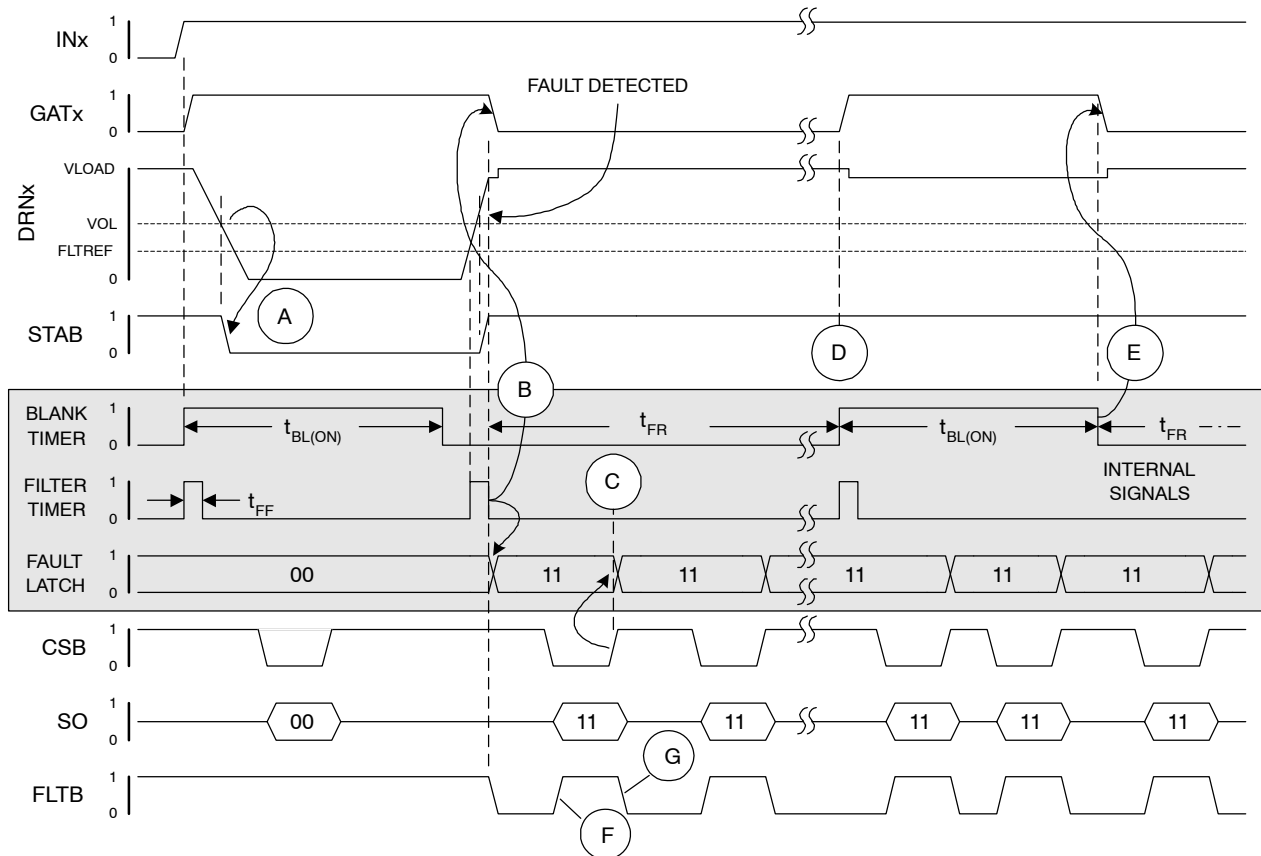

Data bits in the fault latch (00 & 11) represent single channel encoded fault data as described in Table 8.

Figure 19. Shorted Load Detected

Shorted Load Recovery

Figure 19 is a continuation of Figure 18. IN_X is high when the auto-retry timer ends. GAT_X goes high and the blanking and filter timers are started. The fault is removed before the blanking timer ends, and DRN_X starts to fall. As DRN_X passes through the V_{OL} threshold at “A”, the STAB flag is set. DRN_X continues to fall and settles below the $FLTREF$ threshold.

A SPI frame is sent during the blanking time and returns data indicating a “shorted load” fault.

Although the fault is removed, updates to the fault latches are suppressed while a blanking or filter timer is active. The same fault is captured again and FLT_B is set when CSB goes high. At “B” the blanking time ends and the channel’s fault bits will indicate “no fault” but because the

latched data has not yet been read, the data remains unchanged.

The SPI frame sent after the blanking time ends returns a “shorted load” fault because the previous frame occurred during the blanking time.

Since the channel’s fault bits indicate “no fault”, FLT_B is reset and the fault latch is updated at “C” when CSB goes high.

If another SPI frame is sent before “D”, the returned data will indicate “no fault”.

The channel is commanded off at “D”. GAT_X goes low and the timers are started. DRN_X starts to rise and the STAB flag is reset as DRN_X passes through the V_{OL} threshold.

The SPI frame sent at “E” returns data indicating “no fault”.

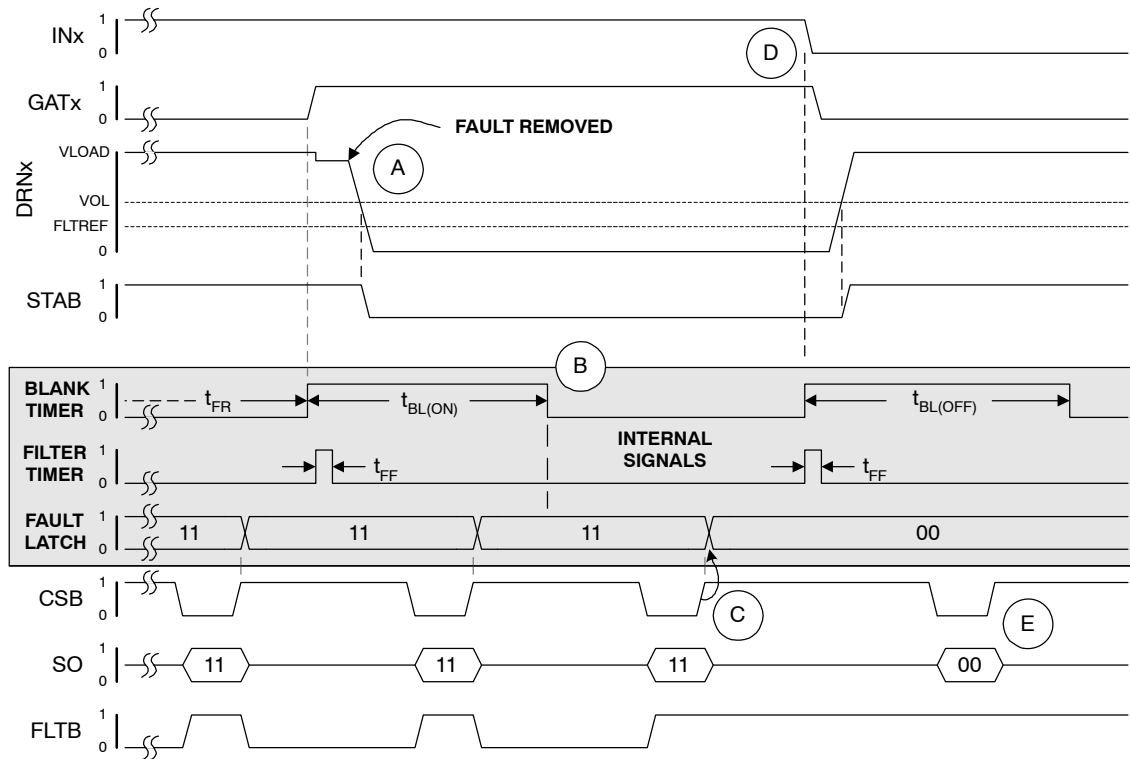

Data bits in the fault latch (00 & 11) represent single channel encoded fault data as described in Table 8.

Figure 20. Shorted Load Recovery

Short to GND/Open Load

Figure 20 illustrates turn-off with an open or high resistance load when some capacitance is present at DRN_X. In the case of an open load, DRN_X rises and settles to V_{CTR} (shown as the solid DRN_X waveform). In the case of a high resistance load, DRN_X may continue to rise and may eventually settle to V_{LOAD}.

Timing diagram description: The channel is commanded off. GAT_X goes low and the timers are started. DRN_X starts to rise and is below the V_{SG} threshold when the blanking time ends at “A”. A short to GND fault is detected and captured by the fault latch, and the FLTB flag is set.

DRN_X continues to rise and as it passes through the V_{SG} threshold at “B”, the filter timer is triggered. At the end of the filter time, the channel’s fault bits will indicate an “open load” but because the latched data has not yet been read, the data remains unchanged.

A SPI frame sent shortly after “B” returns data indicating “short to GND” and the fault latch is updated at “C” when CSB goes high.

The next three SPI frames sent after “C” return data indicating an “open load”.

The STAB flag is reset at “D” as DRN_X passes through the V_{OL} threshold. Note that the filter timer is not triggered as DRN_X passes from a fault state to a good state. The channel’s fault bits will indicate “no fault” but because the latched data has not yet been read, the data remains unchanged.

The fault latch is updated at “E” when CSB goes high and the FLTB flag remains reset.

The next SPI frame sent returns data indicating “no fault”.

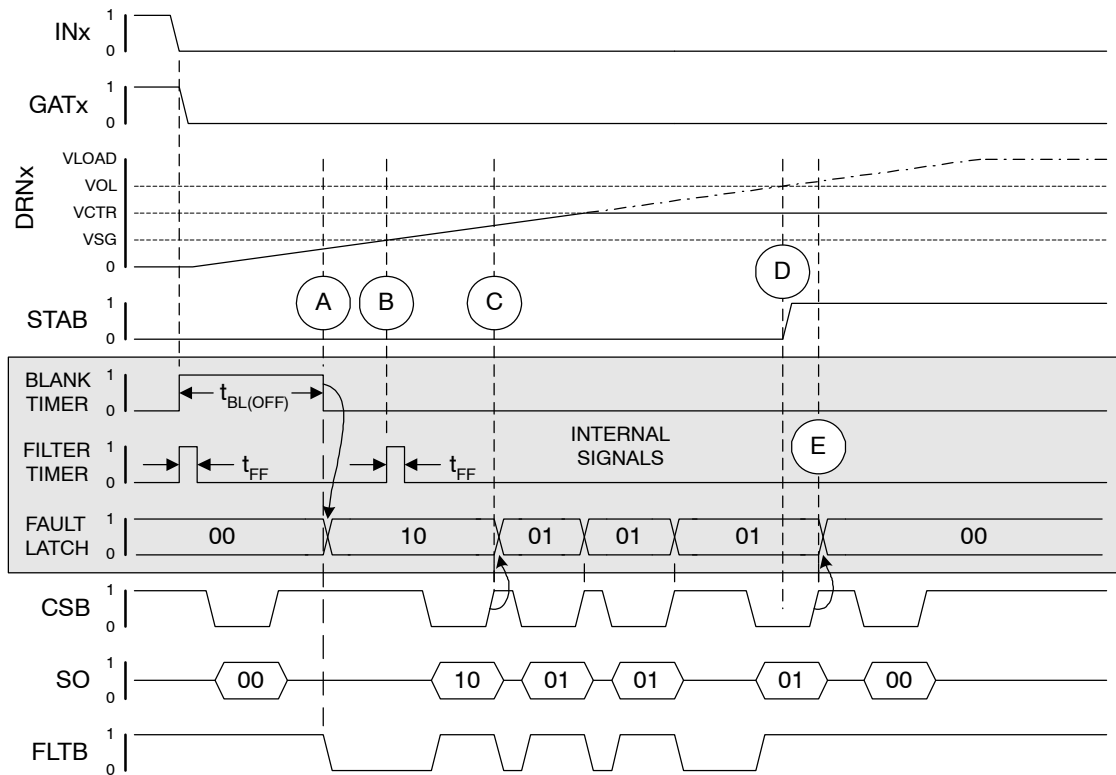

Data bits in the fault latch (00, 01 & 10) represent single channel encoded fault data as described in Table 8.

Figure 21. Short to GND/Open Load

NCV7512

Table 9. I/O Truth Table

Inputs								Outputs*				COMMENT
POR	ENA1	ENA2	CSB	K _X	IN _X	G _X	DRN _X	GAT _X	FLTB	STAB	D _{X1} D _{X0}	
0	X	X	X	→0	X	→0	X	→L	→Z	→Z	→00	POR RESET
1	0	X	X	X	X	X	X	L	Z	Z	00	ENA1
1	1	0	X	K _X	X	G _X	X	L	FLTB	STAB	D _{X1} D _{X0}	ENA2
1	1→0	1	X	K _X	X	→0	X	→L	→Z	→Z	→00	ENA1 RESET
1	1	1→0	X	K _X	X	G _X	X	→L	FLTB	STAB	D _{X1} D _{X0}	ENA2 DISABLE
1	1	X	X	0	X	X	X	L	Z	Z	-	FLAGS MASKED
1	1	0	X	1	X	X	> V _{OL}	L	-	Z	-	STAB RESET
1	1	0	X	1	X	X	< V _{OL}	L	-	L	-	STAB SET
1	1	0	X	1→0	X	X	< V _{OL}	L	-	L→Z	-	STAB RESET
1	1	0	X	0→1	X	X	< V _{OL}	L	-	Z→L	-	STAB SET
1	1	1	X	1	0	0	> V _{OL}	L	Z	Z	00	FLAGS RESET
1	1	1	1	1	0	0	V _{SG} <V<V _{OL}	L	L	L	01	FLAGS SET
1	1	1	X	1→0	0	0	V _{SG} <V<V _{OL}	L	L	L→Z	01	STAB RESET
1	1	1	X	0→1	0	0	V _{SG} <V<V _{OL}	L	L		01	STAB SET
1	1	1	1→0	1	0	0	V _{SG} <V<V _{OL}	L	L→Z	L	01	FLTB RESET
1	1	1	0→1	1	0	0	V _{SG} <V<V _{OL}	L	Z→L	L	01	FLTB SET
1	1	1	1	1	0	0	< V _{SG}	L	L	L	10	FLAGS SET
1	1	1	X	1→0	0	0	< V _{SG}	L	L	L→Z	10	STAB RESET
1	1	1	X	0→1	0	0	< V _{SG}	L	L	Z→L	10	STAB SET
1	1	1	1→0	1	0	0	< V _{SG}	L	L→Z	L	10	FLTB RESET
1	1	1	0→1	1	0	0	< V _{SG}	L	Z→L	L	10	FLTB SET
1	1	1	X	1	1	X	< V _{FLTREF}	H	Z	L	00	STAB SET
1	1	1	1	1	1	X	V _{FLTREF} <V<V _{OL}	L	L	L	11	FLAGS SET
1	1	1	X	1→0	1	X	V _{FLTREF} <V<V _{OL}	L	L	L→Z	11	STAB RESET
1	1	1	X	0→1	1	X	V _{FLTREF} <V<V _{OL}	L	L	Z→L	11	STAB SET
1	1	1	1→0	1	1	X	V _{FLTREF} <V<V _{OL}	L	L→Z	L	11	FLTB RESET
1	1	1	0→1	1	1	X	V _{FLTREF} <V<V _{OL}	L	Z→L	L	11	FLTB SET
1	1	1	1	1	1	X	> V _{OL}	L	L	Z	11	STAB RESET
1	1	1	X	1	X	1	< V _{FLTREF}	H	Z	L	00	STAB SET
1	1	1	1	1	X	1	V _{FLTREF} <V<V _{OL}	L	L	L	11	FLAGS SET
1	1	1	X	1→0	X	1	V _{FLTREF} <V<V _{OL}	L	L	L→Z	11	STAB RESET
1	1	1	X	0→1	X	1	V _{FLTREF} <V<V _{OL}	L	L	Z→L	11	STAB SET
1	1	1	1→0	1	X	1	V _{FLTREF} <V<V _{OL}	L	L→Z	L	11	FLTB RESET
1	1	1	0→1	1	X	1	V _{FLTREF} <V<V _{OL}	L	Z→L	L	11	FLTB SET
1	1	1	1	1	X	1	> V _{OL}	L	L	Z	11	STAB RESET

* Output states after blanking and filter timers end and when channel is set to latch-off mode.

APPLICATION GUIDELINES

General

Unused DRN_X inputs should be connected to V_{CC1} to prevent false open load faults. Unused parallel inputs should be connected to GND and unused enable inputs should be connected to V_{CC1}.

The mask bit for each unused channel should be ‘set’ (see Table 5) to prevent activation of the flags and the user’s software should be designed to ignore fault information for unused channels.

For best shorted-load detection accuracy, the external MOSFET source terminals should be star-connected. The NCV7512’s GND pin and the lower resistor in the fault reference voltage divider should be Kelvin connected to the star (See Figures 2 and 13).

Auto-retry fault recovery behavior is a necessary consideration from a power dissipation viewpoint (for both the NCV7512 and the MOSFETs). EMI should also be evaluated during auto-retry.

Driver slew rate and turn-on/off symmetry can be adjusted externally to the NCV7512 in each channel’s gate circuit by adding a gate series resistor. Resistors and diodes can be added for channel symmetry. Any benefit of EMI reduction by this method comes at the expense of increased switching losses in the MOSFETs.

The channel fault blanking timers must be considered when choosing external components (MOSFETs, slew control resistors, etc.) to avoid false faults. Component choices must ensure that gate circuit charge/discharge times stay within the turn-on/turn-off blanking times.

The NCV7512 does not have integral drain-gate flyback clamps. Clamp MOSFETs, such as ON Semiconductor’s NID9N05CL, are recommended when driving unclamped inductive loads. This flexibility allows choice of MOSFET clamp voltages suitable to each application.

DRN_X Feedback Resistor

Each DRN_X feedback input has a clamp to keep the applied voltage below the breakdown voltage of the NCV7512. An external series resistor (R_{DX}) is required between each DRN_X input and MOSFET drain. Channels may be clamped sequentially or simultaneously but total clamp power is limited by the maximum allowable junction temperature.

To limit power in the DRN_X input clamps and to ensure proper open load or short to GND detection, the R_{DX} resistor must be dimensioned according to the following constraint equations:

$$R_{DX(MIN)} = \frac{V_{PK}-V_{CL(MIN)}}{I_{CL(MAX)}} \quad (eq. 2)$$

$$R_{DX(MAX)} = \frac{V_{SG}-|V_{OS}|}{|I_{SG}|} \quad (eq. 3)$$

Where:

- V_{PK} is the peak transient drain voltage
- V_{CL} is the DRN_X input clamp voltage
- I_{CL(MAX)} is the input clamp current
- V_{SG} short to GND fault detection voltage
- I_{SG} short to GND diagnostic current
- V_{OS} is the allowable offset (1V max) between the NCV7512’s GND and the short.

Once R_{DX} is chosen, the open load and short to GND detection resistances in the application can be predicted:

Once R_{DX} is chosen, the open load and short to GND detection resistances in the application can be predicted:

$$R_{OL} \geq \frac{V_{LOAD}-V_{OL}}{I_{OL}} - R_{DX} \quad (eq. 4)$$

$$R_{SG} \leq \frac{R_{LOAD}(V_{SG} \pm V_{OS}-|I_{SG}|R_{DX})}{V_{LOAD}-V_{SG} + |I_{SG}|(R_{DX} + R_{LOAD})} \quad (eq. 5)$$

Using the data sheet values for V_{CL(MIN)} = 27 V, I_{CL(MAX)} = 10 mA, and choosing V_{PK} = 55 V as an example, Equation 2 evaluates to 2.8 kΩ minimum.

Choosing V_{CC1} = 5.0 V and using the typical data sheet values for V_{SG} = 30%V_{CC1}, I_{SG} = 20 μA, and choosing V_{OS} = 0, Equation 3 evaluates to 75 kΩ maximum.

Selecting R_{DX} = 6.8 kΩ ±5%, V_{CC1} = 5.0 V, V_{LOAD} = 12.0 V, V_{OS} = 0 V, R_{LOAD} = 555 Ω, and using the typical data sheet values for V_{OL}, I_{OL}, V_{SG}, and I_{SG}, Equation 4 predicts an open load detection resistance of 130.7 kΩ.

Equation 5 predicts a short to GND detection resistance of 71.1 Ω.

When R_{DX} and the data sheet values are taken to their extremes, the open load detection range is 94.1 kΩ ≤ R_{OL} ≤ 273.5 kΩ, and the short to GND detection range is 59.2 Ω ≤ R_{SG} ≤ 84.4 Ω.

APPLICATIONS DRAWINGS

Daisy Chain

The NCV7512 is capable of being setup in a daisy chain configuration with other similar devices which include additional NCV7512 devices as well as the NCV7513 Hex Low-Side Predriver. Particular attention should be focused on the fact that the first 16 bits which are clocked out of the

SO pin when the CSB pin transitions from a high to a low will be the Diagnostic Output Data. These are the bits representing the status of the IC and are detailed in Figure 22. Additional programming bits should be clocked in which follow the Diagnostic Output bits.

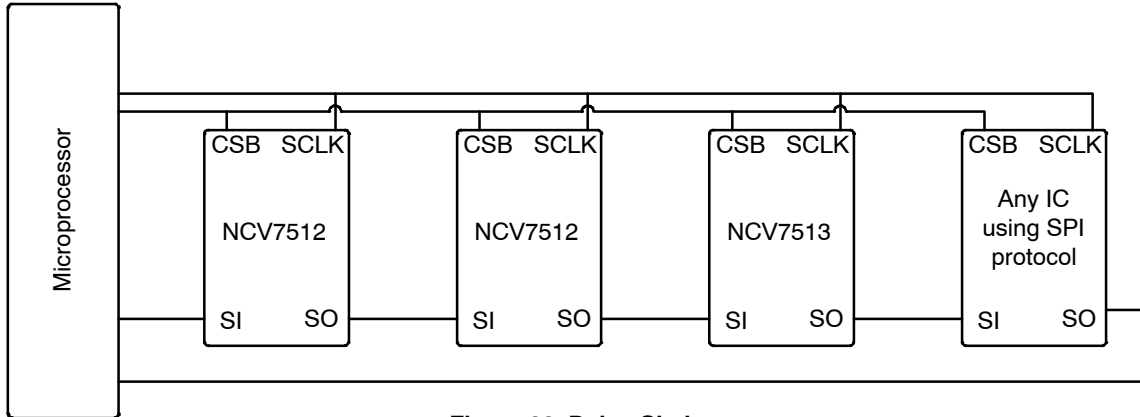

Figure 22. Daisy Chain

Parallel Control (time consideration)

A more efficient way to control multiple SPI compatible devices is to connect them in a parallel fashion and allow each device to be controlled in a multiplex mode. Figure 23 shows a typical connection between the microprocessor or microcontroller and multiple SPI compatible devices. In a daisy chain configuration, the programming information

for the last device in the serial string must first pass through all the previous devices. The parallel control setup eliminates that requirement, but at the cost of additional control pins from the microprocessor for each individual CSB (chip select bar) pin for each controllable device. Serial data is only recognized by the device that is activated through its' respective CSB pin.

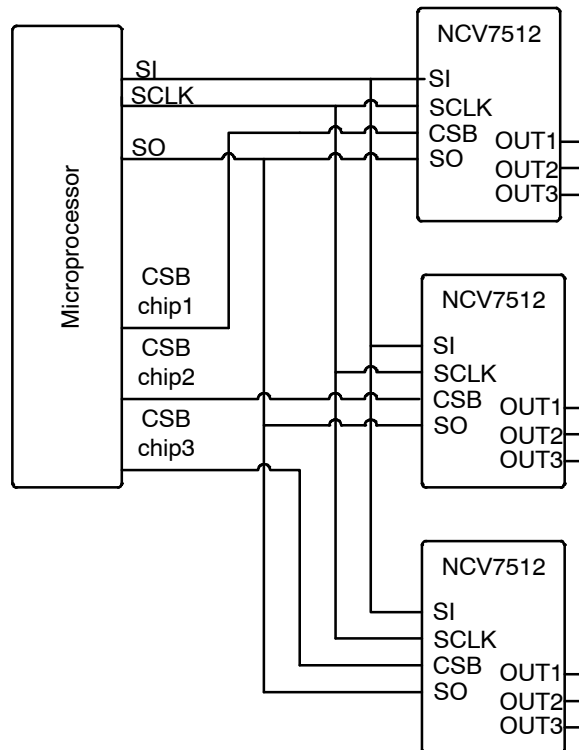
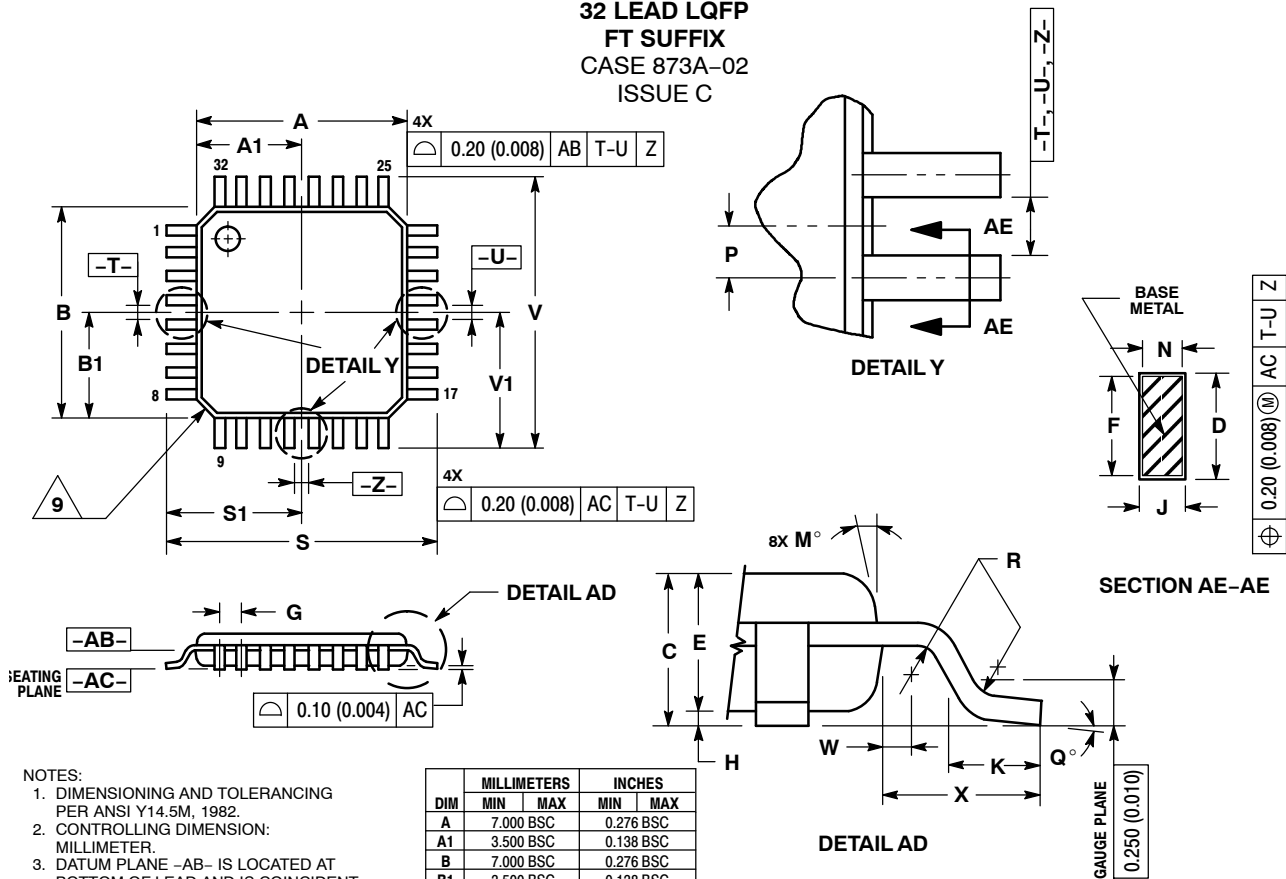

Figure 23. SPI Parallel Control Setup

NCV7512

PACKAGE DIMENSIONS

32 LEAD LQFP
FT SUFFIX
CASE 873A-02
ISSUE C



NOTES:

- DIMENSIONING AND TOLERANCING PER ANSI Y14.5M, 1982.
- CONTROLLING DIMENSION: MILLIMETER.
- DATUM PLANE -AB- IS LOCATED AT BOTTOM OF LEAD AND IS COINCIDENT WITH THE LEAD WHERE THE LEAD EXITS THE PLASTIC BODY AT THE BOTTOM OF THE PARTING LINE.
- DATUMS -T-, -U-, AND -Z- TO BE DETERMINED AT DATUM PLANE -AB-.
- DIMENSIONS S AND V TO BE DETERMINED AT SEATING PLANE -AC-.
- DIMENSIONS A AND B DO NOT INCLUDE MOLD PROTRUSION. ALLOWABLE MOLD PROTRUSION IS 0.250 (0.010) PER SIDE. DIMENSIONS A AND B DO INCLUDE MOLD MISMATCH AND ARE DETERMINED AT DATUM PLANE -AB-.
- DIMENSION D DOES NOT INCLUDE DAMBAR PROTRUSION. DAMBAR PROTRUSION SHALL NOT CAUSE THE D DIMENSION TO EXCEED 0.520 (0.020).
- MINIMUM SOLDER PLATE THICKNESS SHALL BE 0.0076 (0.0003).
- EXACT SHAPE OF EACH CORNER MAY VARY FROM DEPICTION.

FLEXMOS and SMARTDISCRETES are trademarks of Semiconductor Components Industries, LLC (SCILLC).

ON Semiconductor and are registered trademarks of Semiconductor Components Industries, LLC (SCILLC). SCILLC reserves the right to make changes without further notice to any products herein. SCILLC makes no warranty, representation or guarantee regarding the suitability of its products for any particular purpose, nor does SCILLC assume any liability arising out of the application or use of any product or circuit, and specifically disclaims any and all liability, including without limitation special, consequential or incidental damages. "Typical" parameters which may be provided in SCILLC data sheets and/or specifications can and do vary in different applications and actual performance may vary over time. All operating parameters, including "Typicals" must be validated for each customer application by customer's technical experts. SCILLC does not convey any license under its patent rights nor the rights of others. SCILLC products are not designed, intended, or authorized for use as components in systems intended for surgical implant into the body, or other applications intended to support or sustain life, or for any other application in which the failure of the SCILLC product could create a situation where personal injury or death may occur. Should Buyer purchase or use SCILLC products for any such unintended or unauthorized application, Buyer shall indemnify and hold SCILLC and its officers, employees, subsidiaries, affiliates, and distributors harmless against all claims, costs, damages, and expenses, and reasonable attorney fees arising out of, directly or indirectly, any claim of personal injury or death associated with such unintended or unauthorized use, even if such claim alleges that SCILLC was negligent regarding the design or manufacture of the part. SCILLC is an Equal Opportunity/Affirmative Action Employer. This literature is subject to all applicable copyright laws and is not for resale in any manner.

PUBLICATION ORDERING INFORMATION

LITERATURE FULFILLMENT:
Literature Distribution Center for ON Semiconductor
P.O. Box 5163, Denver, Colorado 80217 USA
Phone: 303-675-2175 or 800-344-3860 Toll Free USA/Canada
Fax: 303-675-2176 or 800-344-3867 Toll Free USA/Canada
Email: orderlit@onsemi.com

N. American Technical Support: 800-282-9855 Toll Free USA/Canada
Europe, Middle East and Africa Technical Support:
Phone: 421 33 790 2910
Japan Customer Focus Center
Phone: 81-3-5773-3850

ON Semiconductor Website: www.onsemi.com
Order Literature: <http://www.onsemi.com/orderlit>

For additional information, please contact your local Sales Representative