

# PTN36221A

Single-channel SuperSpeed USB 3.0 redriver

Rev. 2.1 — 25 August 2015

Product data sheet

## 1. General description

The PTN36221A is a small, low power, high performance SuperSpeed USB 3.0 redriver that enhances signal quality by performing receive equalization on the deteriorated input signal followed by transmit de-emphasis maximizing system link performance. With its superior differential signal conditioning and enhancement capability, the device delivers significant flexibility and performance scaling for various systems with different PCB trace and cable channel conditions and still benefit from optimum power consumption.

PTN36221A is a single-channel device that supports data signaling rate of 5 Gbit/s.

The PTN36221A has built-in advanced power management capability that enables significant power saving under various different USB 3.0 Low-power modes (U2/U3). The device performs these actions without host software intervention and conserves power.

The PTN36221A is powered by a 1.8 V supply. It is available in X2QFN12 1.6 mm × 1.6 mm × 0.35 mm package with 0.4 mm pitch.

## 2. Features and benefits

- Supports single-channel USB 3.0 redriver at 5 Gbit/s
- Compliant to SuperSpeed USB 3.0 standard
- Supports Low Frequency Periodic Signaling (LFPS) and is USB3.0 compatible
- Adjustable receive equalization, transmit de-emphasis and output swing functions
  - ◆ Selectable receive equalization to recover from InterSymbol Interference (ISI) and high-frequency losses
  - ◆ Selectable transmit de-emphasis and output swing delivers pre-compensation suited to channel conditions
  - ◆ Selectable output swing adjustment
- Integrated termination resistors provide impedance matching on both transmit and receive paths
- Automatic receiver termination detection
- Low power management scheme (When  $V_{DD} = 1.8\text{ V}$ ,  $V_{os} = 1000\text{ mV}$ )
  - ◆ 97 mW active power
  - ◆ 5 mW in U2/U3 state
  - ◆ 1 mW with no connection
  - ◆ 18  $\mu\text{W}$  in Deep power saving state
- Support hot plug with automatic receiver detect
- Power supply:  $1.8\text{ V} \pm 5\%$
- ESD 8 kV HBM, 1 kV CDM for data path
- Operating temperature range:  $-40\text{ }^{\circ}\text{C}$  to  $+85\text{ }^{\circ}\text{C}$



- Package offered: X2QFN12 package 1.6 mm × 1.6 mm × 0.35 mm, 0.4 mm pitch

### 3. Applications

- Smart phones, tablets
- Active cables
- Notebook/netbook/nettop platforms
- Docking stations
- Desktop and AIO platforms
- Server and storage platforms
- USB 3.0 peripherals such as consumer/storage devices, printers, or USB 3.0 capable hubs/repeaters

### 4. System context diagrams

The system context diagrams in [Figure 1](#) illustrate PTN36221A usage.

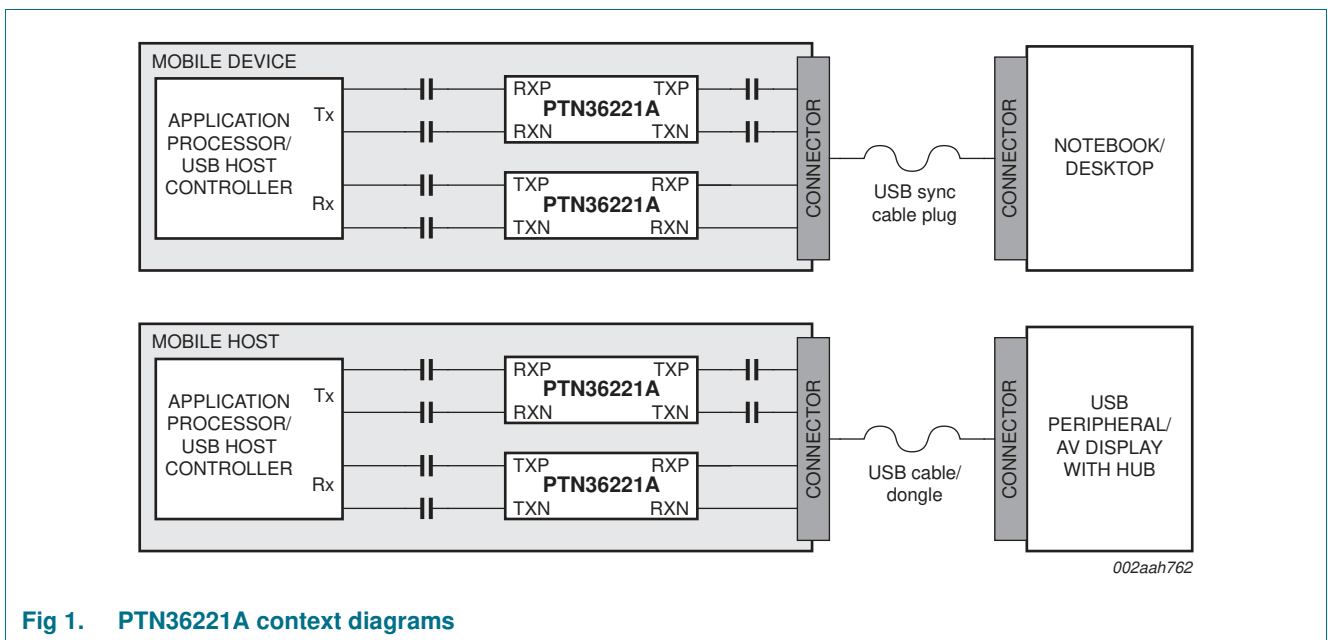

Fig 1. PTN36221A context diagrams

## 5. Ordering information

Table 1. Ordering information

Type number	Topside mark	Package		
		Name	Description	Version
PTN36221AHX	1A*[1]	X2QFN12	plastic, super thin quad flat package; no leads; 12 terminals; body 1.6 × 1.6 × 0.35 mm[2]	SOT1355-1

[1] Where \* = week of the month.

[2] Maximum package height = 0.4 mm.

### 5.1 Ordering options

Table 2. Ordering options

Type number	Orderable part number	Package	Packing method	Minimum order quantity	Temperature
PTN36221AHX	PTN36221AHXHP	X2QFN12	Reel 13" Q2/T3 *Standard mark SMD	10000	T <sub>amb</sub> = -40 °C to +85 °C
	PTN36221AHXZ	X2QFN12	Reel 7" Q2/T3 *Standard mark	5000	T <sub>amb</sub> = -40 °C to +85 °C

## 6. Block diagram

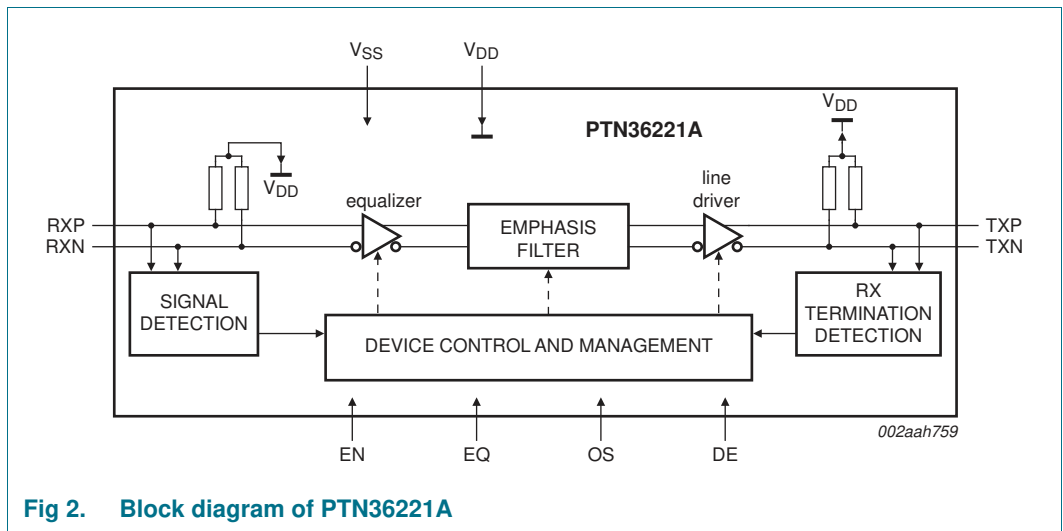
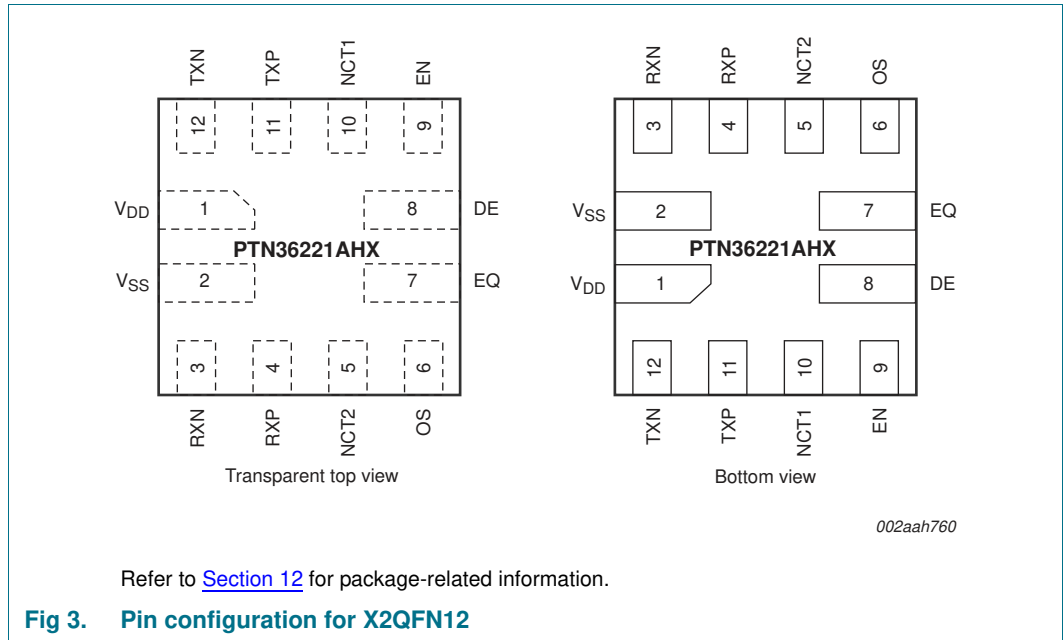

Fig 2. Block diagram of PTN36221A

## 7. Pinning information

### 7.1 Pinning



### 7.2 Pin description

Table 3. Pin description

Symbol	Pin	Type	Description
<b>High-speed differential signals</b>			
RXP	4	self-biasing differential input	Differential signal from SuperSpeed USB 3.0 transmitter. RXP makes a differential pair with RXN. The input to this pin must be AC-coupled externally.
RXN	3	self-biasing differential input	Differential signal from SuperSpeed USB 3.0 transmitter. RXN makes a differential pair with RXP. The input to this pin must be AC-coupled externally.
TXP	11	self-biasing differential output	Differential signal to SuperSpeed USB 3.0 receiver. TXP makes a differential pair with TXN. The output of this pin must be AC-coupled externally.
TXN	12	self-biasing differential output	Differential signal to SuperSpeed USB 3.0 receiver. TXN makes a differential pair with TXP. The output of this pin must be AC-coupled externally.
<b>Control and configuration signals</b>			
NCT1	10	CMOS input	Test pin 1. Leave open or connect to ground for functional mode.
NCT2	5	analog input	Test pin 2. Leave open or connect to ground for functional mode.
EN	9	CMOS input	Chip enable input (active HIGH); internal 260 kΩ pull-up resistor.

**Table 3. Pin description ...continued**

Symbol	Pin	Type	Description
DE	8	Trinary input	Programmable output de-emphasis level setting for the output channel. [DE] = LOW: 0 dB open: -3.5 dB (default) HIGH: -6 dB
EQ	7	Trinary input	Equalizer control for the input channel. [EQ] = LOW: 3 dB open: 6 dB (default) HIGH: 9 dB
OS	6	Trinary input	Differential output swing control. [OS] = LOW: 900 mV open: 1000 mV (default) HIGH: 1100 mV
<b>Supply voltage</b>			
V <sub>DD</sub>	1	Power	1.8 V supply.
<b>Ground connection</b>			
V <sub>SS</sub>	2	Ground	Ground supply (0 V).

## 8. Functional description

Refer to [Figure 2 “Block diagram of PTN36221A”](#).

PTN36221A is a single-channel SuperSpeed USB 3.0 redriver meant to be used for signal integrity enhancement on various platforms — smart phone, tablet, active cable, notebooks, docking station, desktop, AIO, peripheral devices, etc. With its high fidelity differential signal conditioning capability and wide configurability, this chip is flexible enough for use under a variety of system environments.

The following sections describe the individual block functions and capabilities of the device in more detail.

### 8.1 Receive equalization

On the high-speed signal path, the device performs receive equalization providing frequency selective gain to configuration pin EQ setting. [Table 4](#) lists the configuration options available in this device.

**Table 4. EQ configuration options**

EQ	SuperSpeed USB 3.0 signal equalization gain at 2.5 GHz
LOW (0 V)	3 dB
Open	6 dB (default)
HIGH (1.8 V)	9 dB

### 8.2 Transmit de-emphasis

The PTN36221A device enhances High Frequency (HF) signal content further by performing de-emphasis on the high-speed signals. In addition, the device provides flat frequency gain by boosting output signal. Both flat and frequency selective gains prepare the system to cover up for losses further down the link. [Table 5](#) lists de-emphasis configuration options of PTN36221A.

**Table 5. DE configuration options**

DE	SuperSpeed USB 3.0 signal de-emphasis gain
LOW (0 V)	0 dB
Open	-3.5 dB (default)
HIGH (1.8 V0)	-6 dB

[Figure 4](#) illustrates de-emphasis as a function of time.

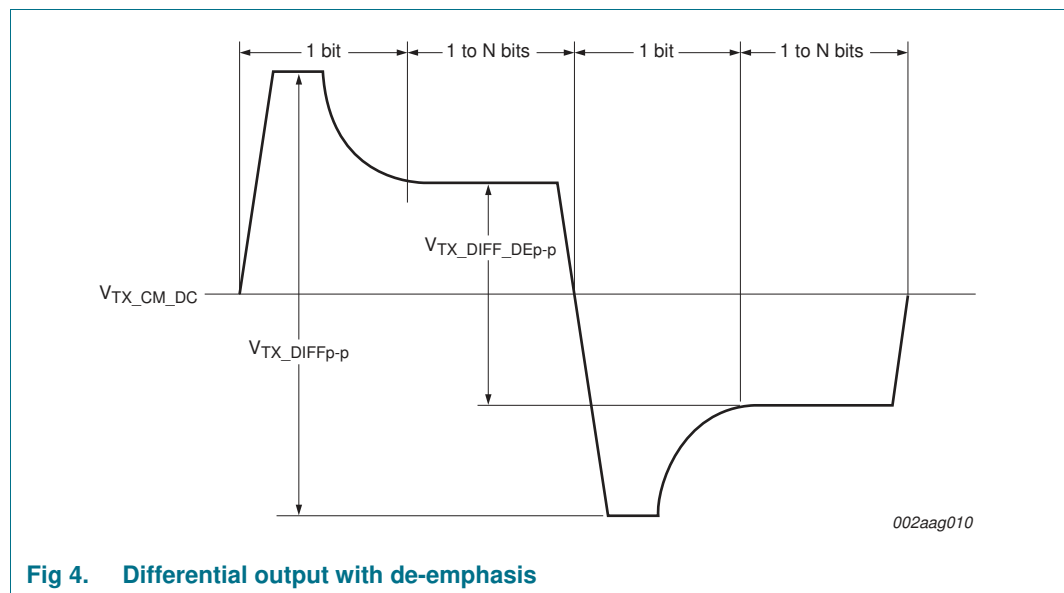

**Fig 4. Differential output with de-emphasis**

### 8.3 Device states and power management

PTN36221A has implemented an advanced power management scheme that operates in tune with USB 3.0 bus electrical condition. Though the device does not decode USB power management commands (related to USB 3.0 U1/U2/U3 transitions) exchanged between USB 3.0 host and peripheral/device, it relies on bus electrical conditions to decide to be in one of the following states:

- **Active state** wherein device is fully operational, USB data is transported. In this state, USB connection exists, but there is no need for Receive Termination detection.
- **Power-saving states:**
  - U2/U3 state
  - No connection state
- **Deep power-saving state:** When EN is LOW, this chip is in shut-down state.

The Receive Termination Detection circuitry is implemented as part of a transmitter and detect whether a load device with equivalent DC impedance  $Z_{RX\_DC}$  is present.

## 9. Limiting values

**Table 6. Limiting values**

In accordance with the Absolute Maximum Rating System (IEC 60134).

Symbol	Parameter	Conditions	Min	Max	Unit
V <sub>DD</sub>	supply voltage		[1] -0.3	+2.5	V
V <sub>I</sub>	input voltage		[1] -0.3	V <sub>DD</sub> + 0.5	V
T <sub>stg</sub>	storage temperature		-65	+150	°C
V <sub>ESD</sub>	electrostatic discharge voltage	HBM for high-speed pins	[2] -	8000	V
		HBM for control pins	[2] -	4000	V
		CDM for high-speed pins	[3] -	1000	V
		CDM for control pins	[3] -	500	V

[1] All voltage values (except differential voltages) are with respect to network ground terminal.

[2] Human Body Model: ANSI/ESDA/JEDEC JDS-001-2012 (Revision of ANSI/ESDA/JEDEC JS-001-2011), ESDA/JEDEC Joint standard for ESD sensitivity testing, Human Body Model - Component level; Electrostatic Discharge Association, Rome, NY, USA; JEDEC Solid State Technology Association, Arlington, VA, USA.

[3] Charged Device Model; JESD22-C101E December 2009 (Revision of JESD220C101D, October 2008), standard for ESD sensitivity testing, Charged Device Model - Component level; JEDEC Solid State Technology Association, Arlington, VA, USA.

## 10. Recommended operating conditions

**Table 7. Operating conditions**

Symbol	Parameter	Conditions	Min	Typ	Max	Unit
V <sub>DD</sub>	supply voltage	1.8 V supply option	1.71	1.8	1.89	V
V <sub>I</sub>	input voltage	control and configuration pins (for example, EQ, DE, OS and EN)	-0.3	V <sub>DD</sub>	V <sub>DD</sub> + 0.3	V
T <sub>amb</sub>	ambient temperature	operating in free air	-40	-	+85	°C

## 11. Characteristics

### 11.1 Device characteristics

**Table 8. Device characteristics**

$V_{DD} = 1.8\text{ V} \pm 5\%$ ;  $T_{amb} = -40\text{ }^{\circ}\text{C}$  to  $+85\text{ }^{\circ}\text{C}$ , unless otherwise specified.

Symbol	Parameter	Conditions	Min	Typ	Max	Unit
$t_{\text{startup}}$	start-up time	between supply voltage within operating range to specified operating characteristics (90 % of $V_{DD}$ ) until first automatic receiver termination detection	-	-	6	ms
$t_{\text{s(HL)}}$	HIGH to LOW settling time	enable to disable; power-down time; EN HIGH → LOW change to deep power-saving state; device is supplied with valid supply voltage	-	-	1	ms
$t_{\text{s(LH)}}$	LOW to HIGH settling time	disable to enable; start-up time; EN LOW → HIGH change to specified operating characteristics; device is supplied with valid supply voltage	-	-	6	ms
$t_{\text{rcfg}}$	reconfiguration time	any configuration pin change (from one setting to another setting) to specified operating characteristics; device is supplied with valid supply voltage	-	-	115	ms
$t_{\text{PD(dif)}}$	differential propagation delay	between 50 % level at input and output; see <a href="#">Figure 5</a>	-	-	0.5	ns
$t_{\text{idle}}$	idle time	default wait time to wait before getting into Power-saving state	-	300	400	ms
$t_{\text{d(pwrsave-act)}}$	delay time from power-save to active	time for exiting from Power-saving state and get into Active state; see <a href="#">Figure 7</a>	-	0.1	115 <sup>[1]</sup>	μs
$t_{\text{d(act-idle)}}$	delay time from active to idle	reaction time for squelch detection circuit and transmitter output buffer; see <a href="#">Figure 6</a>	-	9	14	ns
$t_{\text{d(idle-act)}}$	delay time from idle to active	reaction time for squelch detection circuit and transmitter output buffer; see <a href="#">Figure 6</a>	-	9	14	ns
$I_{DD}$	supply current	Active state; Tx de-emphasis = -3.5 dB; Rx equalization gain = 6 dB; Tx output signal swing (peak-to-peak) = 1000 mV	-	57	-	mA
		U2/U3 Power-saving state	-	2.8		mA
		no USB connection state	-	0.4		mA
		Deep power-saving state; EN = LOW	-	10		μA
$R_{\text{th(j-a)}}$	thermal resistance from junction to ambient	JEDEC still air test environment	-	138.5	-	°C/W

[1] When special U2/U3 Power-saving mode is ON.



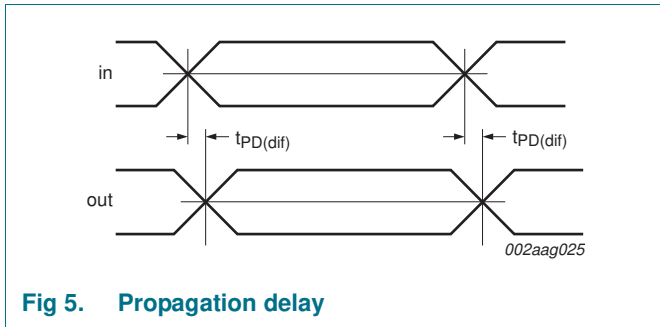

Fig 5. Propagation delay

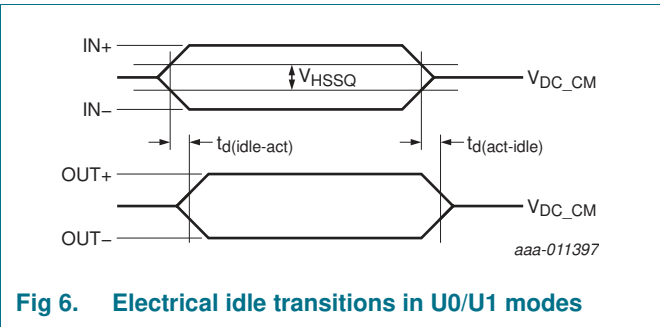

Fig 6. Electrical idle transitions in U0/U1 modes

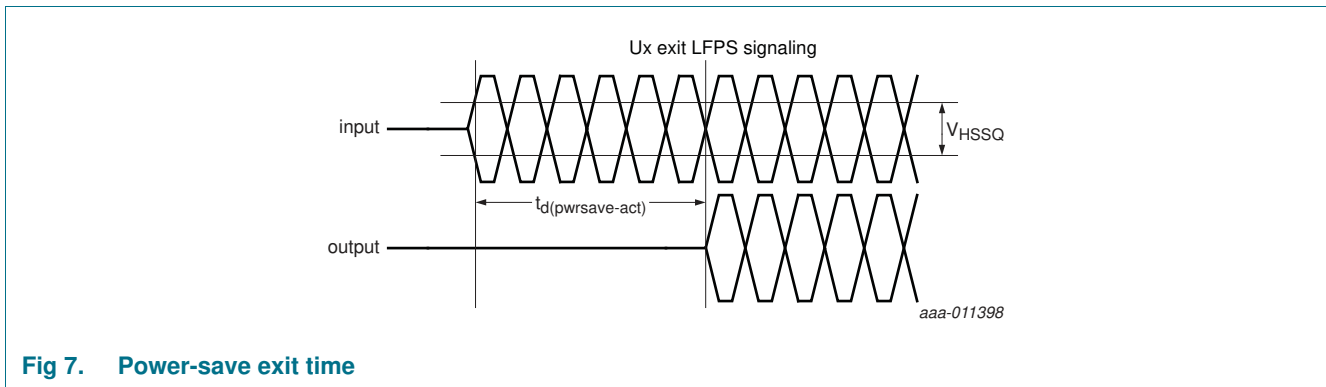

Fig 7. Power-save exit time

## 11.2 Receiver AC/DC characteristics

Table 9. Receiver AC/DC characteristics

$V_{DD} = 1.8 V \pm 5\%$ ;  $T_{amb} = -40\text{ }^{\circ}\text{C}$  to  $+85\text{ }^{\circ}\text{C}$ , unless otherwise specified.

Symbol	Parameter	Conditions	Min	Typ	Max	Unit
$Z_{RX\_DC}$	receiver DC common-mode impedance		18	-	30	$\Omega$
$Z_{RX\_DIFF\_DC}$	DC differential impedance	RX pair	72	-	120	$\Omega$
$Z_{IH}$	HIGH-level input impedance	DC input; common-mode	25	-	-	$k\Omega$
$V_{RX\_DIFFp-p}$	differential input peak-to-peak voltage	receiver	100	-	1200	mV
$V_{RX\_DC\_CM}$	RX DC common mode voltage		-	1.8	-	V
$V_{RX\_CM\_AC\_P}$	RX AC common-mode voltage	peak	-	-	150	mV
$V_{th(i)}$	input threshold voltage	differential peak-to-peak value	100	-	-	mV
$V_{HSSQ}$	high-speed squelch detection threshold voltage (differential signal amplitude)	differential peak-to-peak value	-	100	-	mV

11.3 Transmitter AC/DC characteristics

Table 10. Transmitter AC/DC characteristics

$V_{DD} = 1.8 V \pm 5\%$ ;  $T_{amb} = -40\text{ }^{\circ}\text{C}$  to  $+85\text{ }^{\circ}\text{C}$ , unless otherwise specified.

Symbol	Parameter	Conditions	Min	Typ	Max	Unit
$Z_{TX\_DC}$	transmitter DC common-mode impedance		18	-	30	$\Omega$
$Z_{TX\_DIFF\_DC}$	DC differential impedance	TX pair	72	-	120	$\Omega$
$V_{TX\_DIFFp-p}$	differential peak-to-peak output voltage	$R_L = 100\ \Omega$				
		OS = open	900	1000	1100	mV
		OS = HIGH	1000	1100	1200	mV
		OS = LOW	800	900	1000	mV
$V_{TX\_DC\_CM}$	transmitter DC common-mode voltage		-	1.3	$V_{DD}$	V
$V_{TX\_CM\_ACpp\_ACTIV}$	TX AC common-mode peak-to-peak output voltage (active state)	device input fed with differential signal	-	-	100	mV
$V_{TX\_IDL\_DIFF\_ACpp}$	electrical idle differential peak-to-peak output voltage	when link is in electrical idle	-	-	10	mV
$V_{TX\_RCV\_DETECT}$	voltage change allowed during receiver detection	positive voltage swing to sense the receiver termination detection	-	-	600	mV
$t_{r(tx)}$	transmit rise time	measured using 20 % and 80 % levels; see Figure 8	40	55	75	ps
$t_{f(tx)}$	transmit fall time	measured using 80 % and 20 % levels; see Figure 8	40	55	75	ps
$t_{(r-f)tx}$	difference between transmit rise and fall time	measured using 20 % and 80 % levels	-	-	15	ps

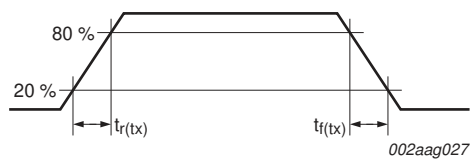

Fig 8. Output rise and fall times

### 11.4 Jitter performance

Table 11 provides jitter performance of PTN36221A under a specific set of conditions that is illustrated by Figure 9.

**Table 11. Jitter performance characteristics**

Unit Interval (UI) = 200 ps.

Symbol	Parameter	Conditions	Min	Typ	Max	Unit	
$t_{jit(o)(p-p)}$	peak-to-peak output jitter time	total jitter at test point C	[1]	-	0.19	-	UI
$t_{jit(dtrm)(p-p)}$	peak-to-peak deterministic jitter time		[1]	-	0.11	-	UI
$t_{jit(rndm)(p-p)}$	peak-to-peak random jitter time		[1][2]	-	0.08	-	UI

[1] Measured at test point C with K28.5 pattern,  $V_{ID} = 1000$  mV (peak-to-peak), 5 Gbit/s; -3.5 dB de-emphasis from source.

[2] Random jitter calculated as 14.069 times the RMS random jitter for  $10^{-12}$  bit error rate.

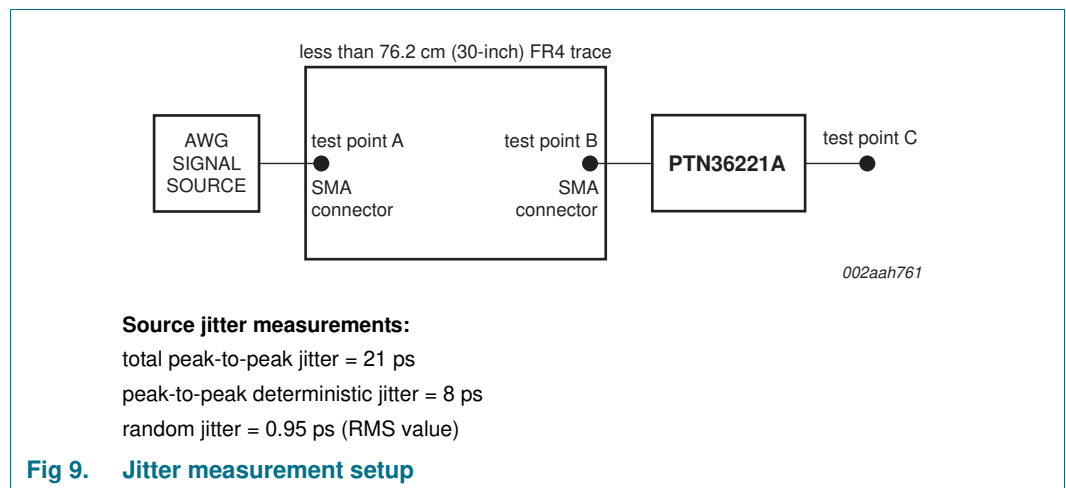

### 11.5 Control inputs

**Table 12. Control input characteristics for EN pin**

$V_{DD} = 1.8 V \pm 5\%$ ;  $T_{amb} = -40\text{ }^{\circ}\text{C}$  to  $+85\text{ }^{\circ}\text{C}$ , unless otherwise specified.

Symbol	Parameter	Conditions	Min	Typ	Max	Unit
$V_{IH}$	HIGH-level input voltage		$0.65 \times V_{DD}$	-	-	V
$V_{IL}$	LOW-level input voltage		-	-	$0.35 \times V_{DD}$	V
$I_{LI}$	input leakage current	measured with input at $V_{IH(max)}$ and $V_{IL(min)}$	-	7	20	$\mu\text{A}$
$R_{pu(int)}$	internal pull-up resistance		-	230	-	$\text{k}\Omega$

**Table 13. Trinary control input characteristics for DE, EQ, and OS pins***V<sub>DD</sub> = 1.8 V ± 5 %; T<sub>amb</sub> = -40 °C to +85 °C, unless otherwise specified.*

Symbol	Parameter	Conditions	Min	Typ	Max	Unit
V <sub>IH</sub>	HIGH-level input voltage		0.75 × V <sub>DD</sub>	V <sub>DD</sub>	V <sub>DD</sub> + 0.3	V
V <sub>IL</sub>	LOW-level input voltage		-0.3	0	0.25 × V <sub>DD</sub>	V
I <sub>IH</sub>	HIGH-level input current		-	-	45	μA
I <sub>IL</sub>	LOW-level input current		-45	-	-	μA
Z <sub>ext(open)</sub>	external impedance	for detection of open condition	250	-	-	kΩ
I <sub>L</sub>	leakage current	of external GPIO; for detection of open condition	-6	-	+6	μA
C <sub>L</sub>	load capacitance	for reliable detection of open condition	-	-	35	pF
I <sub>LI</sub>	input leakage current	EN = LOW; measured with input at V <sub>IH(max)</sub> and V <sub>IL(min)</sub>	-	-	1	μA
R <sub>pu(int)</sub>	internal pull-up resistance	for detection of trinary setting	-	50	-	kΩ
R <sub>pd(int)</sub>	internal pull-down resistance	for detection of trinary setting	-	50	-	kΩ

12. Package outline

X2QFN12: plastic, super thin quad flat package; no leads; 12 terminals; body 1.6 x 1.6 x 0.35 mm

SOT1355-1

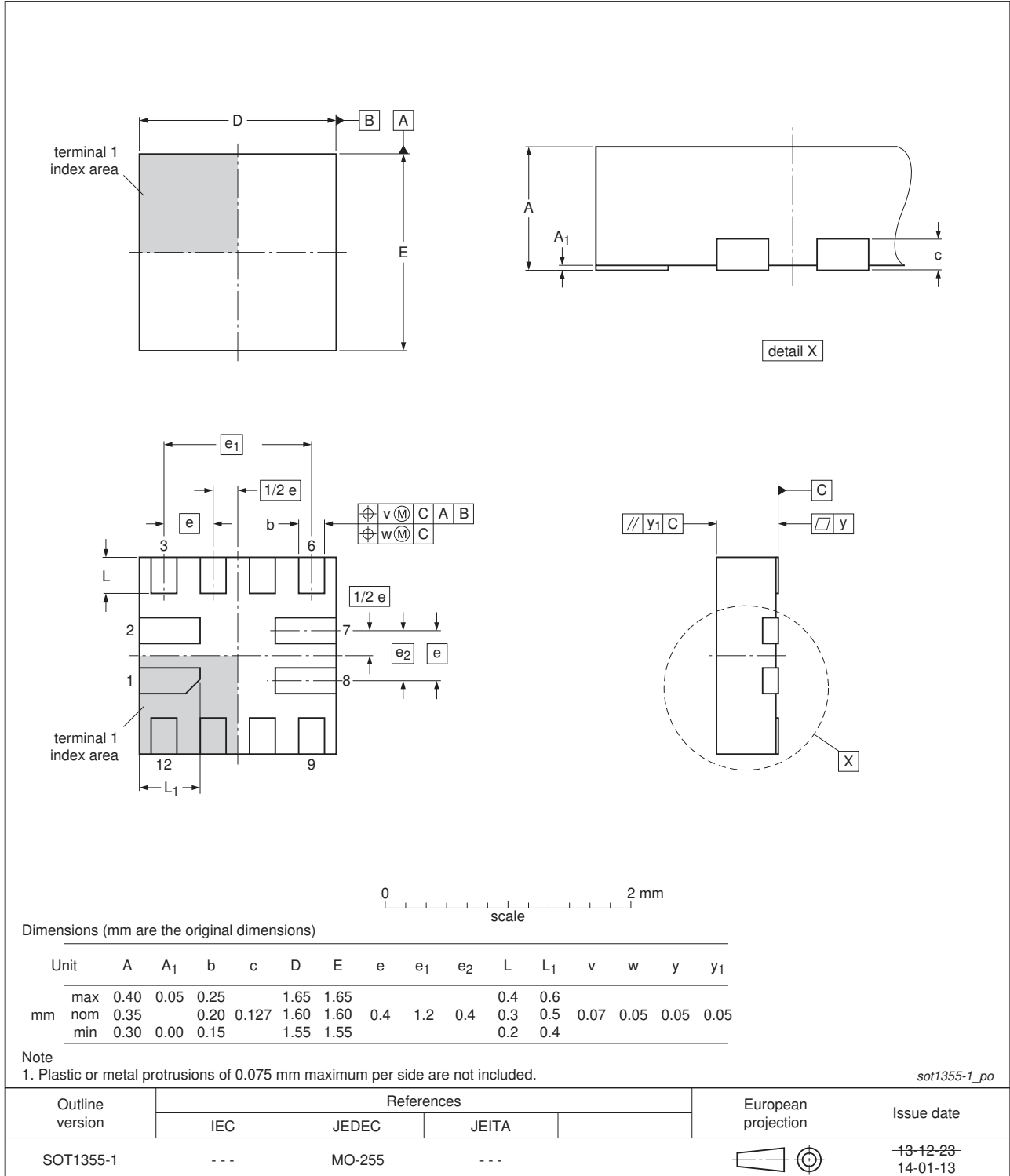
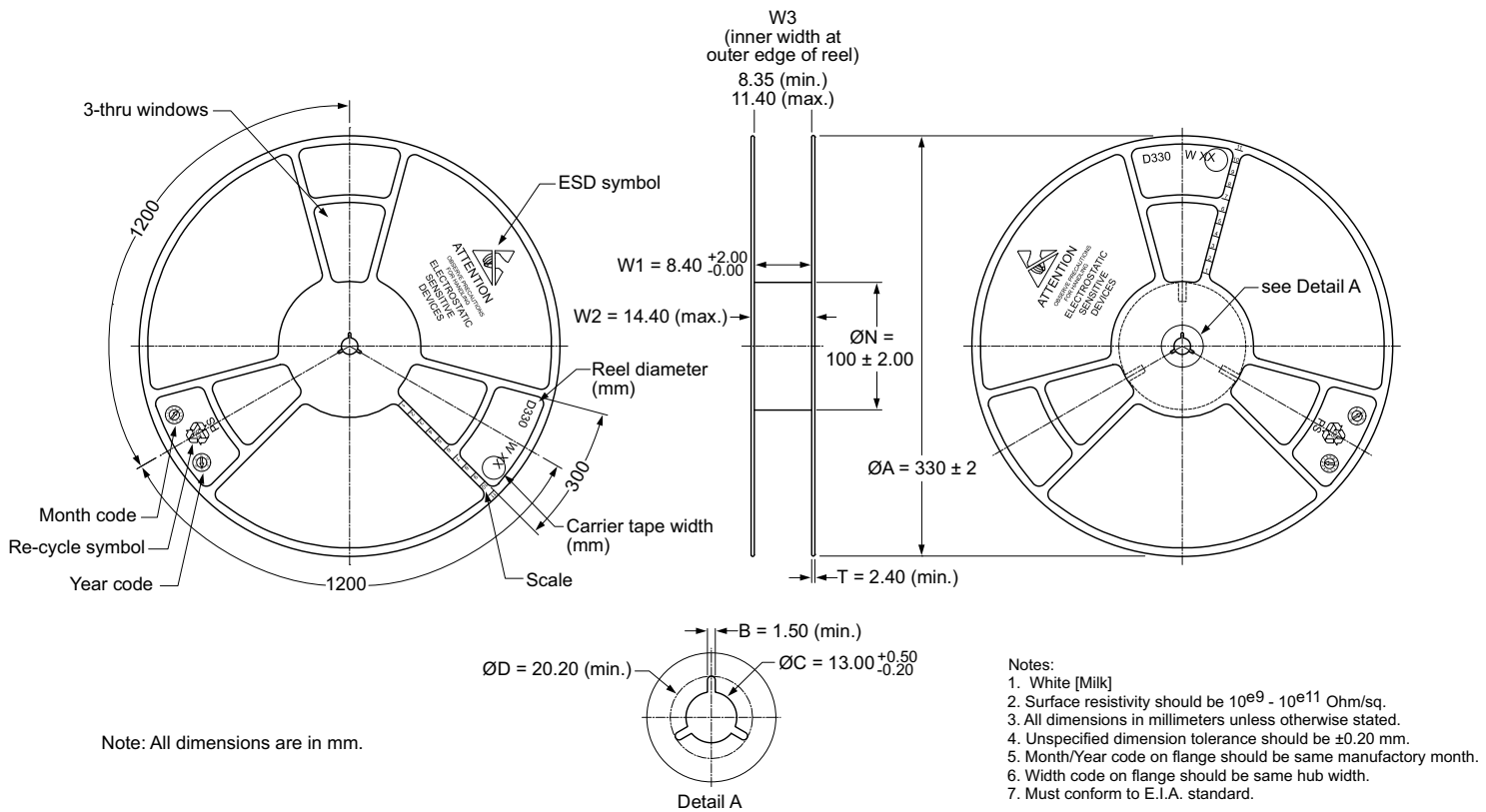

Fig 10. Package outline SOT1355-1 (X2QFN12)

### 13. Packing information



aaa-008944

Fig 11. 13" reel dimensions (13-inch diameter; 4-inch hub; 8 mm carrier tape)

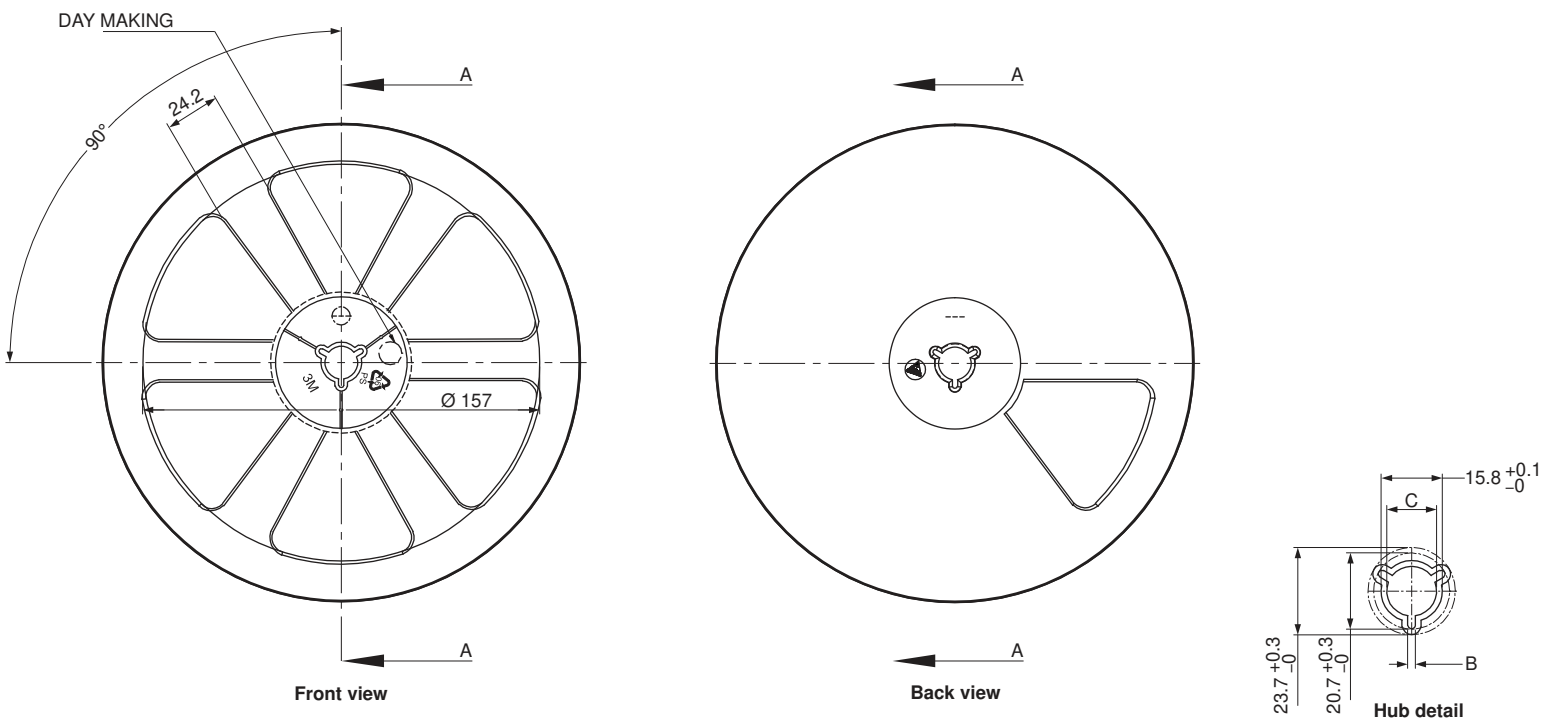

aaa-010094

**NOTE:**

1. Material: PS (Polystyrene)
2. Reel dimension unit = mm.

Reel Diameter A	Reel Diameter B	N	C
180 <sup>+1</sup> <sub>-0</sub>	1.75 <sup>+0.05</sup> <sub>-0.05</sub>	54.5 <sup>+0.5</sup> <sub>-0.5</sub>	13 <sup>+0.25</sup> <sub>-0.25</sub>

3. Width

Carrier Tape	Inside W1	Outside W2	Outside W3
8	8.4 <sup>+1.5</sup> <sub>-0</sub>	11.4 <sup>+1.0</sup> <sub>-1.0</sub>	8.4 <sup>+2.7</sup> <sub>-0</sub>

Fig 12. 7" reel dimensions (7-inch diameter; 2-inch hub; 8 mm carrier tape)

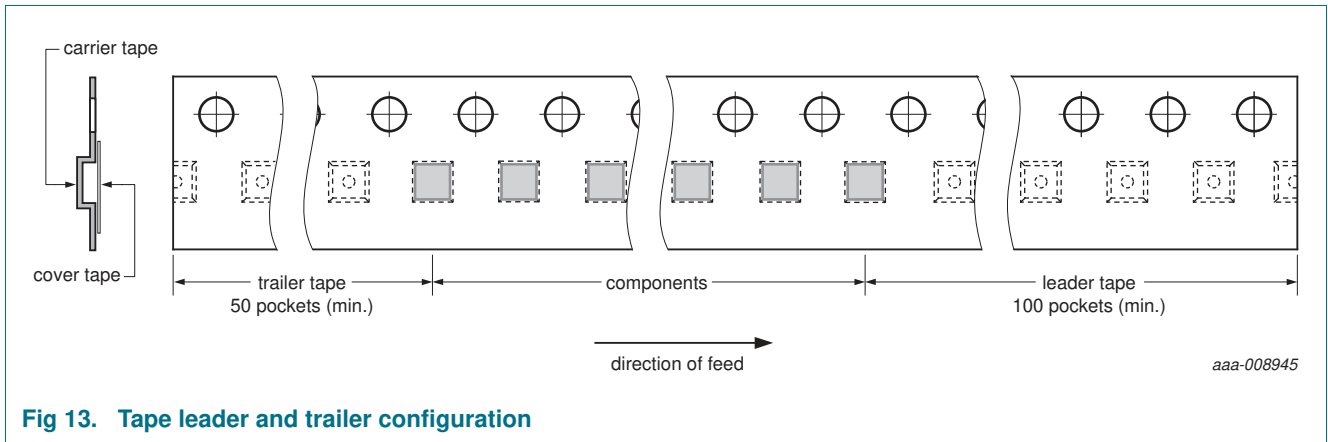

Fig 13. Tape leader and trailer configuration

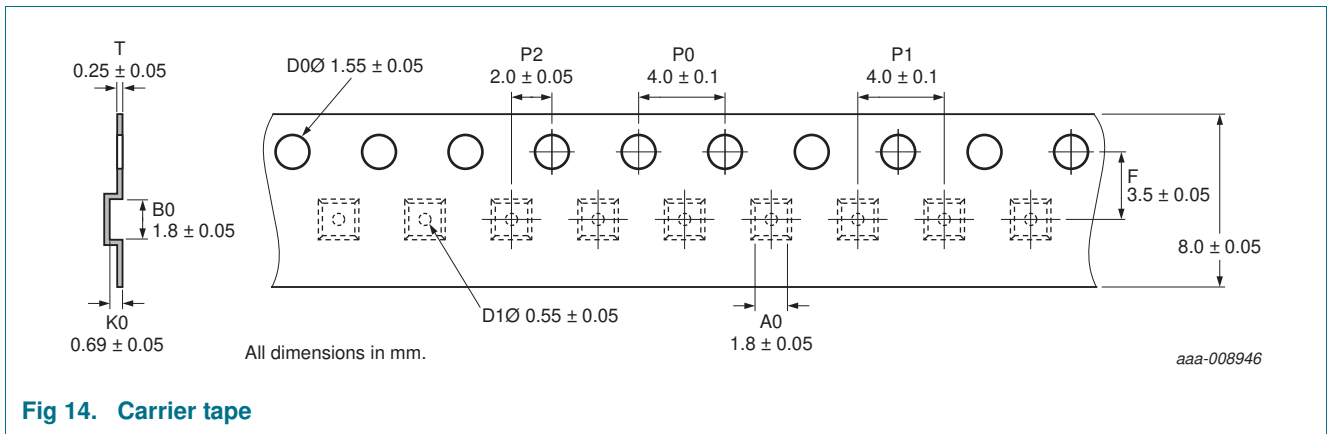

Fig 14. Carrier tape

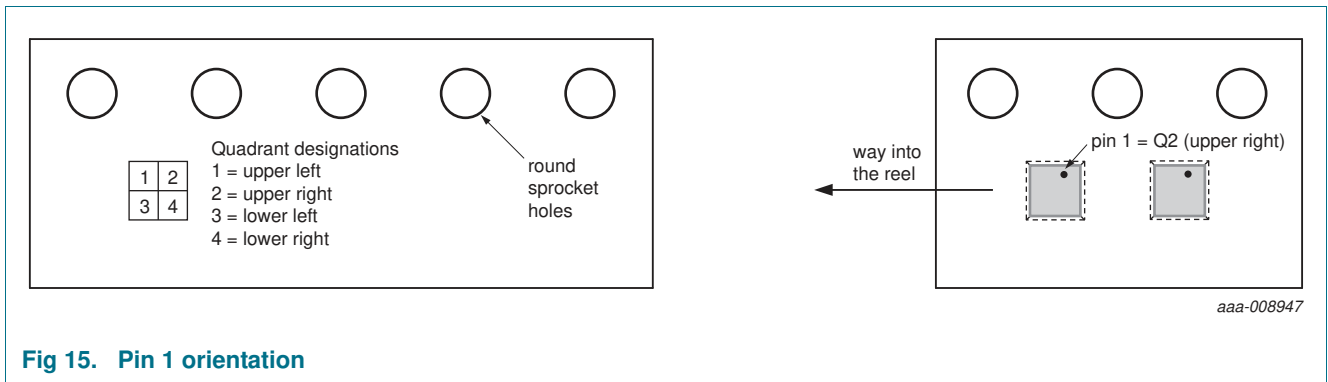

Fig 15. Pin 1 orientation



## 14. Soldering of SMD packages

This text provides a very brief insight into a complex technology. A more in-depth account of soldering ICs can be found in Application Note *AN10365 "Surface mount reflow soldering description"*.

### 14.1 Introduction to soldering

Soldering is one of the most common methods through which packages are attached to Printed Circuit Boards (PCBs), to form electrical circuits. The soldered joint provides both the mechanical and the electrical connection. There is no single soldering method that is ideal for all IC packages. Wave soldering is often preferred when through-hole and Surface Mount Devices (SMDs) are mixed on one printed wiring board; however, it is not suitable for fine pitch SMDs. Reflow soldering is ideal for the small pitches and high densities that come with increased miniaturization.

### 14.2 Wave and reflow soldering

Wave soldering is a joining technology in which the joints are made by solder coming from a standing wave of liquid solder. The wave soldering process is suitable for the following:

- Through-hole components
- Leaded or leadless SMDs, which are glued to the surface of the printed circuit board

Not all SMDs can be wave soldered. Packages with solder balls, and some leadless packages which have solder lands underneath the body, cannot be wave soldered. Also, leaded SMDs with leads having a pitch smaller than ~0.6 mm cannot be wave soldered, due to an increased probability of bridging.

The reflow soldering process involves applying solder paste to a board, followed by component placement and exposure to a temperature profile. Leaded packages, packages with solder balls, and leadless packages are all reflow solderable.

Key characteristics in both wave and reflow soldering are:

- Board specifications, including the board finish, solder masks and vias
- Package footprints, including solder thieves and orientation
- The moisture sensitivity level of the packages
- Package placement
- Inspection and repair
- Lead-free soldering versus SnPb soldering

### 14.3 Wave soldering

Key characteristics in wave soldering are:

- Process issues, such as application of adhesive and flux, clinching of leads, board transport, the solder wave parameters, and the time during which components are exposed to the wave
- Solder bath specifications, including temperature and impurities

### 14.4 Reflow soldering

Key characteristics in reflow soldering are:

- Lead-free versus SnPb soldering; note that a lead-free reflow process usually leads to higher minimum peak temperatures (see [Figure 16](#)) than a SnPb process, thus reducing the process window
- Solder paste printing issues including smearing, release, and adjusting the process window for a mix of large and small components on one board
- Reflow temperature profile; this profile includes preheat, reflow (in which the board is heated to the peak temperature) and cooling down. It is imperative that the peak temperature is high enough for the solder to make reliable solder joints (a solder paste characteristic). In addition, the peak temperature must be low enough that the packages and/or boards are not damaged. The peak temperature of the package depends on package thickness and volume and is classified in accordance with [Table 14](#) and [15](#)

**Table 14. SnPb eutectic process (from J-STD-020D)**

Package thickness (mm)	Package reflow temperature (°C)	
	Volume (mm <sup>3</sup> )	
	< 350	≥ 350
< 2.5	235	220
≥ 2.5	220	220

**Table 15. Lead-free process (from J-STD-020D)**

Package thickness (mm)	Package reflow temperature (°C)		
	Volume (mm <sup>3</sup> )		
	< 350	350 to 2000	> 2000
< 1.6	260	260	260
1.6 to 2.5	260	250	245
> 2.5	250	245	245

Moisture sensitivity precautions, as indicated on the packing, must be respected at all times.

Studies have shown that small packages reach higher temperatures during reflow soldering, see [Figure 16](#).

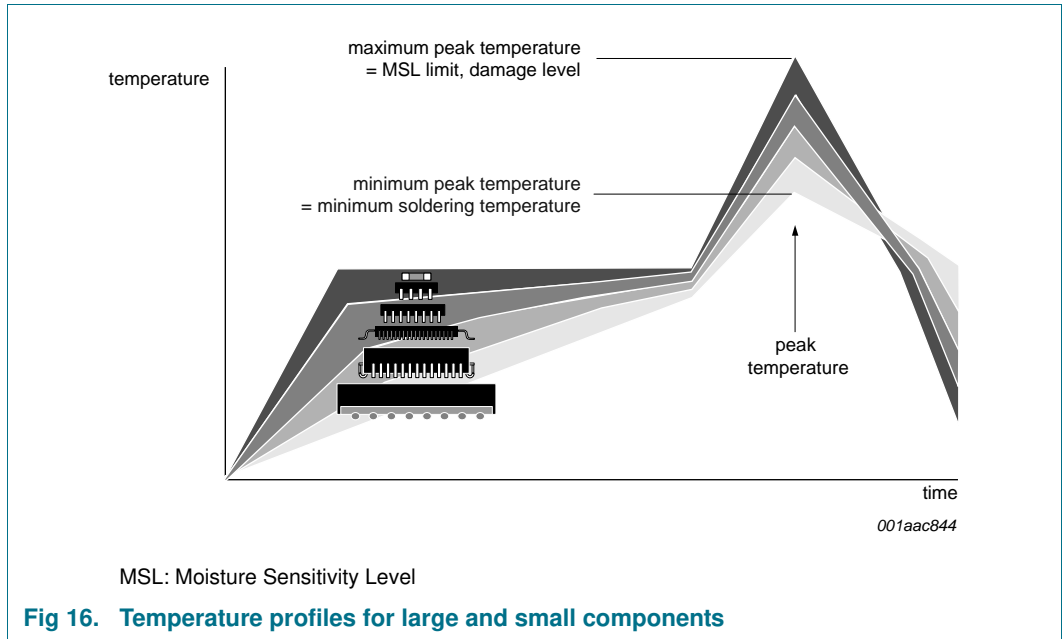

For further information on temperature profiles, refer to Application Note AN10365 "Surface mount reflow soldering description".

### 15. Soldering: PCB footprints

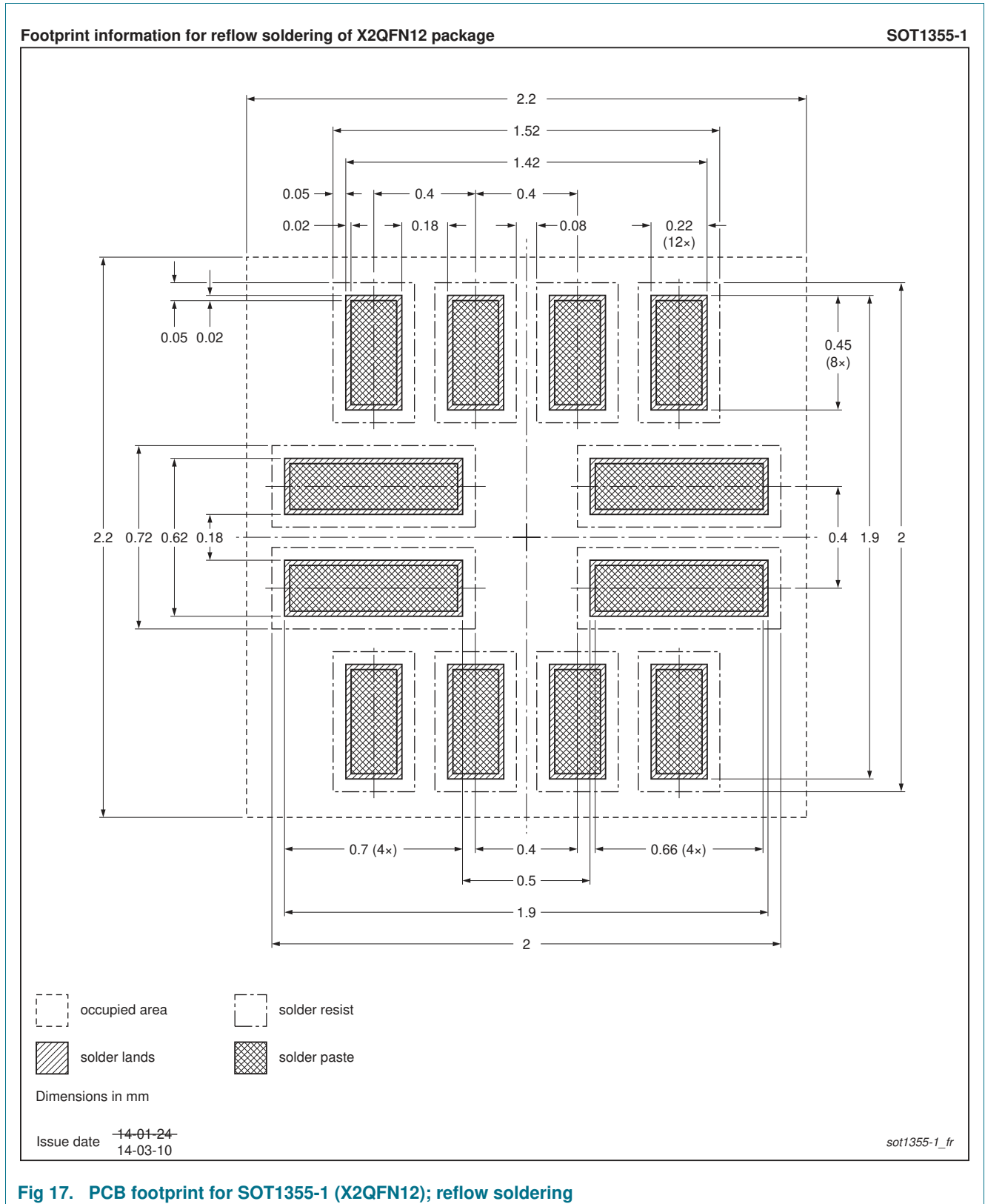

Fig 17. PCB footprint for SOT1355-1 (X2QFN12); reflow soldering

## 16. Abbreviations

Table 16. Abbreviations

Acronym	Description
AIO	All In One computer platform
CDM	Charged-Device Model
HBM	Human Body Model
IC	Integrated Circuit
LFPS	Low Frequency Periodic Sampling
PCB	Printed-Circuit Board
Rx	Receive
SI	Signal Integrity
Tx	Transmit
UI	Unit Interval
USB	Universal Serial Bus

## 17. Revision history

Table 17. Revision history

Document ID	Release date	Data sheet status	Change notice	Supersedes
PTN36221A v.2.1	20150825	Product data sheet	-	PTN36221A v.2
Modifications:	<ul style="list-style-type: none"> <li><a href="#">Table 13 “Trinary control input characteristics for DE, EQ, and OS pins”</a>: Added <math>V_{IH}</math>, <math>V_{IL}</math>, <math>I_{IH}</math>, <math>I_{IL}</math>, <math>Z_{ext(open)}</math>, <math>I_I</math>, and <math>C_L</math>.</li> </ul>			
PTN36221A v.2	20140909	Product data sheet	-	PTN36221A v.1
Modifications:	<ul style="list-style-type: none"> <li>Added <a href="#">Section 15 “Soldering: PCB footprints”</a></li> </ul>			
PTN36221A v.1	20140120	Product data sheet	-	-

## 18. Legal information

### 18.1 Data sheet status

Document status <sup>[1][2]</sup>	Product status <sup>[3]</sup>	Definition
Objective [short] data sheet	Development	This document contains data from the objective specification for product development.
Preliminary [short] data sheet	Qualification	This document contains data from the preliminary specification.
Product [short] data sheet	Production	This document contains the product specification.

[1] Please consult the most recently issued document before initiating or completing a design.

[2] The term 'short data sheet' is explained in section "Definitions".

[3] The product status of device(s) described in this document may have changed since this document was published and may differ in case of multiple devices. The latest product status information is available on the Internet at URL <http://www.nxp.com>.

### 18.2 Definitions

**Draft** — The document is a draft version only. The content is still under internal review and subject to formal approval, which may result in modifications or additions. NXP Semiconductors does not give any representations or warranties as to the accuracy or completeness of information included herein and shall have no liability for the consequences of use of such information.

**Short data sheet** — A short data sheet is an extract from a full data sheet with the same product type number(s) and title. A short data sheet is intended for quick reference only and should not be relied upon to contain detailed and full information. For detailed and full information see the relevant full data sheet, which is available on request via the local NXP Semiconductors sales office. In case of any inconsistency or conflict with the short data sheet, the full data sheet shall prevail.

**Product specification** — The information and data provided in a Product data sheet shall define the specification of the product as agreed between NXP Semiconductors and its customer, unless NXP Semiconductors and customer have explicitly agreed otherwise in writing. In no event however, shall an agreement be valid in which the NXP Semiconductors product is deemed to offer functions and qualities beyond those described in the Product data sheet.

### 18.3 Disclaimers

**Limited warranty and liability** — Information in this document is believed to be accurate and reliable. However, NXP Semiconductors does not give any representations or warranties, expressed or implied, as to the accuracy or completeness of such information and shall have no liability for the consequences of use of such information. NXP Semiconductors takes no responsibility for the content in this document if provided by an information source outside of NXP Semiconductors.

In no event shall NXP Semiconductors be liable for any indirect, incidental, punitive, special or consequential damages (including - without limitation - lost profits, lost savings, business interruption, costs related to the removal or replacement of any products or rework charges) whether or not such damages are based on tort (including negligence), warranty, breach of contract or any other legal theory.

Notwithstanding any damages that customer might incur for any reason whatsoever, NXP Semiconductors' aggregate and cumulative liability towards customer for the products described herein shall be limited in accordance with the *Terms and conditions of commercial sale* of NXP Semiconductors.

**Right to make changes** — NXP Semiconductors reserves the right to make changes to information published in this document, including without limitation specifications and product descriptions, at any time and without notice. This document supersedes and replaces all information supplied prior to the publication hereof.

**Suitability for use** — NXP Semiconductors products are not designed, authorized or warranted to be suitable for use in life support, life-critical or safety-critical systems or equipment, nor in applications where failure or malfunction of an NXP Semiconductors product can reasonably be expected to result in personal injury, death or severe property or environmental damage. NXP Semiconductors and its suppliers accept no liability for inclusion and/or use of NXP Semiconductors products in such equipment or applications and therefore such inclusion and/or use is at the customer's own risk.

**Applications** — Applications that are described herein for any of these products are for illustrative purposes only. NXP Semiconductors makes no representation or warranty that such applications will be suitable for the specified use without further testing or modification.

Customers are responsible for the design and operation of their applications and products using NXP Semiconductors products, and NXP Semiconductors accepts no liability for any assistance with applications or customer product design. It is customer's sole responsibility to determine whether the NXP Semiconductors product is suitable and fit for the customer's applications and products planned, as well as for the planned application and use of customer's third party customer(s). Customers should provide appropriate design and operating safeguards to minimize the risks associated with their applications and products.

NXP Semiconductors does not accept any liability related to any default, damage, costs or problem which is based on any weakness or default in the customer's applications or products, or the application or use by customer's third party customer(s). Customer is responsible for doing all necessary testing for the customer's applications and products using NXP Semiconductors products in order to avoid a default of the applications and the products or of the application or use by customer's third party customer(s). NXP does not accept any liability in this respect.

**Limiting values** — Stress above one or more limiting values (as defined in the Absolute Maximum Ratings System of IEC 60134) will cause permanent damage to the device. Limiting values are stress ratings only and (proper) operation of the device at these or any other conditions above those given in the Recommended operating conditions section (if present) or the Characteristics sections of this document is not warranted. Constant or repeated exposure to limiting values will permanently and irreversibly affect the quality and reliability of the device.

**Terms and conditions of commercial sale** — NXP Semiconductors products are sold subject to the general terms and conditions of commercial sale, as published at <http://www.nxp.com/profile/terms>, unless otherwise agreed in a valid written individual agreement. In case an individual agreement is concluded only the terms and conditions of the respective agreement shall apply. NXP Semiconductors hereby expressly objects to applying the customer's general terms and conditions with regard to the purchase of NXP Semiconductors products by customer.

**No offer to sell or license** — Nothing in this document may be interpreted or construed as an offer to sell products that is open for acceptance or the grant, conveyance or implication of any license under any copyrights, patents or other industrial or intellectual property rights.

**Export control** — This document as well as the item(s) described herein may be subject to export control regulations. Export might require a prior authorization from competent authorities.

**Non-automotive qualified products** — Unless this data sheet expressly states that this specific NXP Semiconductors product is automotive qualified, the product is not suitable for automotive use. It is neither qualified nor tested in accordance with automotive testing or application requirements. NXP Semiconductors accepts no liability for inclusion and/or use of non-automotive qualified products in automotive equipment or applications.

In the event that customer uses the product for design-in and use in automotive applications to automotive specifications and standards, customer (a) shall use the product without NXP Semiconductors' warranty of the product for such automotive applications, use and specifications, and (b) whenever customer uses the product for automotive applications beyond

NXP Semiconductors' specifications such use shall be solely at customer's own risk, and (c) customer fully indemnifies NXP Semiconductors for any liability, damages or failed product claims resulting from customer design and use of the product for automotive applications beyond NXP Semiconductors' standard warranty and NXP Semiconductors' product specifications.

**Translations** — A non-English (translated) version of a document is for reference only. The English version shall prevail in case of any discrepancy between the translated and English versions.

## 18.4 Trademarks

Notice: All referenced brands, product names, service names and trademarks are the property of their respective owners.

## 19. Contact information

For more information, please visit: <http://www.nxp.com>

For sales office addresses, please send an email to: [salesaddresses@nxp.com](mailto:salesaddresses@nxp.com)

## 20. Contents

<b>1</b>	<b>General description</b> .....	<b>1</b>
<b>2</b>	<b>Features and benefits</b> .....	<b>1</b>
<b>3</b>	<b>Applications</b> .....	<b>2</b>
<b>4</b>	<b>System context diagrams</b> .....	<b>2</b>
<b>5</b>	<b>Ordering information</b> .....	<b>3</b>
5.1	Ordering options .....	3
<b>6</b>	<b>Block diagram</b> .....	<b>3</b>
<b>7</b>	<b>Pinning information</b> .....	<b>4</b>
7.1	Pinning .....	4
7.2	Pin description .....	4
<b>8</b>	<b>Functional description</b> .....	<b>5</b>
8.1	Receive equalization .....	5
8.2	Transmit de-emphasis .....	6
8.3	Device states and power management .....	6
<b>9</b>	<b>Limiting values</b> .....	<b>7</b>
<b>10</b>	<b>Recommended operating conditions</b> .....	<b>7</b>
<b>11</b>	<b>Characteristics</b> .....	<b>8</b>
11.1	Device characteristics .....	8
11.2	Receiver AC/DC characteristics .....	9
11.3	Transmitter AC/DC characteristics .....	10
11.4	Jitter performance .....	11
11.5	Control inputs .....	11
<b>12</b>	<b>Package outline</b> .....	<b>13</b>
<b>13</b>	<b>Packing information</b> .....	<b>14</b>
<b>14</b>	<b>Soldering of SMD packages</b> .....	<b>17</b>
14.1	Introduction to soldering .....	17
14.2	Wave and reflow soldering .....	17
14.3	Wave soldering .....	17
14.4	Reflow soldering .....	18
<b>15</b>	<b>Soldering: PCB footprints</b> .....	<b>20</b>
<b>16</b>	<b>Abbreviations</b> .....	<b>21</b>
<b>17</b>	<b>Revision history</b> .....	<b>21</b>
<b>18</b>	<b>Legal information</b> .....	<b>22</b>
18.1	Data sheet status .....	22
18.2	Definitions .....	22
18.3	Disclaimers .....	22
18.4	Trademarks .....	23
<b>19</b>	<b>Contact information</b> .....	<b>23</b>
<b>20</b>	<b>Contents</b> .....	<b>24</b>

Please be aware that important notices concerning this document and the product(s) described herein, have been included in section 'Legal information'.

© NXP Semiconductors N.V. 2015.

All rights reserved.

For more information, please visit: <http://www.nxp.com>

For sales office addresses, please send an email to: [salesaddresses@nxp.com](mailto:salesaddresses@nxp.com)

Date of release: 25 August 2015

Document identifier: PTN36221A