

LAN7500 Customer Evaluation Board

Assy 6588
PCB Revision A
Schematic Revision 1.1

Design Details

Board:
Assy 6588

Chip:
SMSC LAN7500

Board Form Factor:
USB / Ethernet Stand-Alone PCB

Assembly:
56 Lead QFN w/ Exposed GND Pad

Circuit Diagrams utilizing SMSC Products Are Included As A Means Of Illustrating Typical Semiconductor Applications: Consequently Complete Information Sufficient For Construction Purposes Is Not Necessarily Given. The Information Has Been Carefully Checked And Is Believed To Be Entirely Reliable. However, No Responsibility Is Assumed For Inaccuracies. Furthermore, Such Information Does Not Convey To The Purchaser Of The Semiconductor Devices Described Any License Under The Patent Rights Of SMSC Or Others. SMSC Reserves The Right To Make Changes At Any Time In Order To Improve Design And Supply The Best Product Possible.

Revision History

Rev 1.0:

Initial release, Rev A

Rev 1.0 to 1.1:

Page 2: Removed 1.0M crystal circuit parallel resistor (R20).
Page 2: Correction to LAN7500 part number reference.

BLOCK DIAGRAM

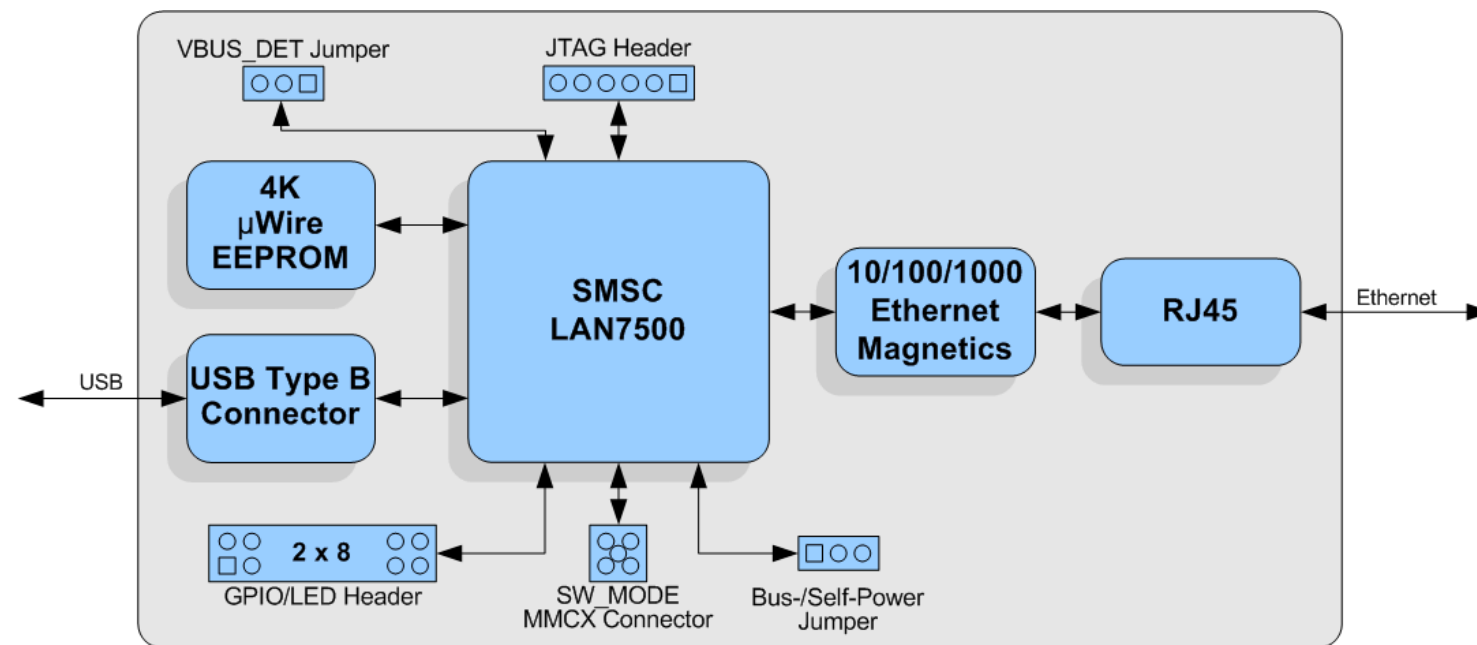

ITEM	Page(s)
Title Page	1
LAN7500, Ethernet, USB, Magnetics, EEPROM, Power	2



Title LAN7500 USB 2.0-to-10/100/1000 Ethernet Customer EVB				
Size	Engineer	Assembly No.	PCB Rev	Schematic Rev
C	R. W.	6588	A	1.1
Date:	Wednesday, November 04, 2009			Sheet 1 of 2

LEDS

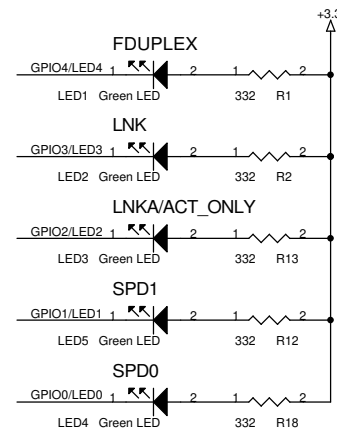

EEPROM Enable Jumper

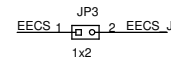

LAN7500 + Ethernet

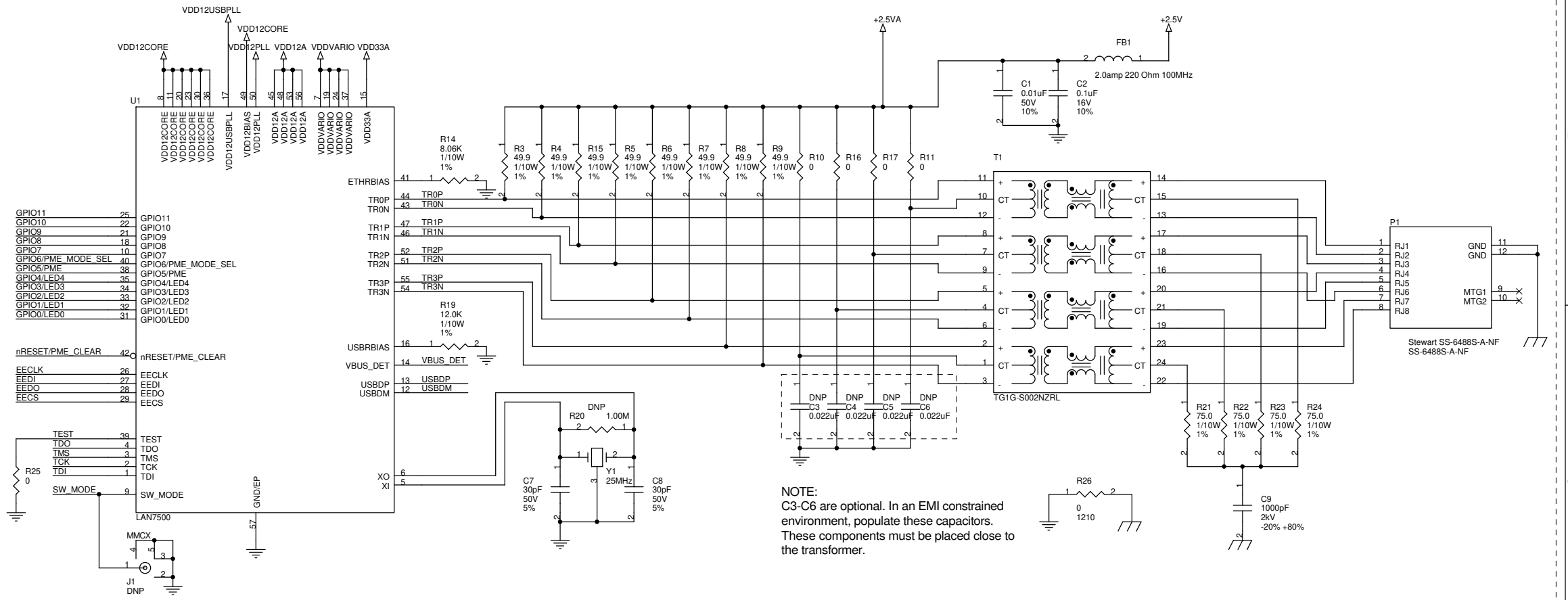

NOTE: C3-C6 are optional. In an EMI constrained environment, populate these capacitors. These components must be placed close to the transformer.

Misc.

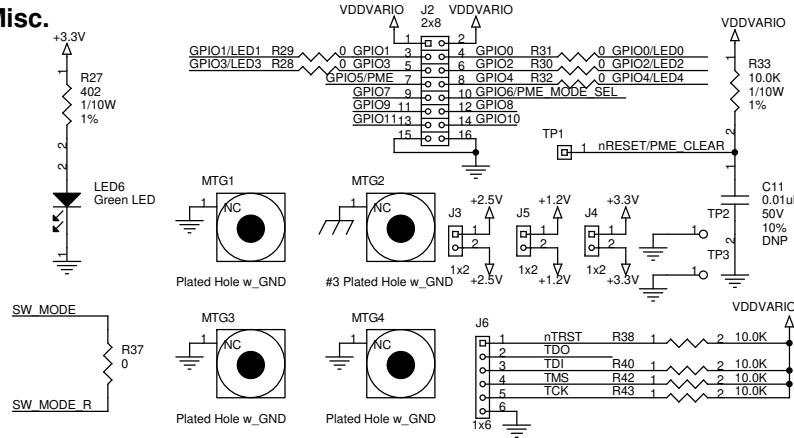

Upstream

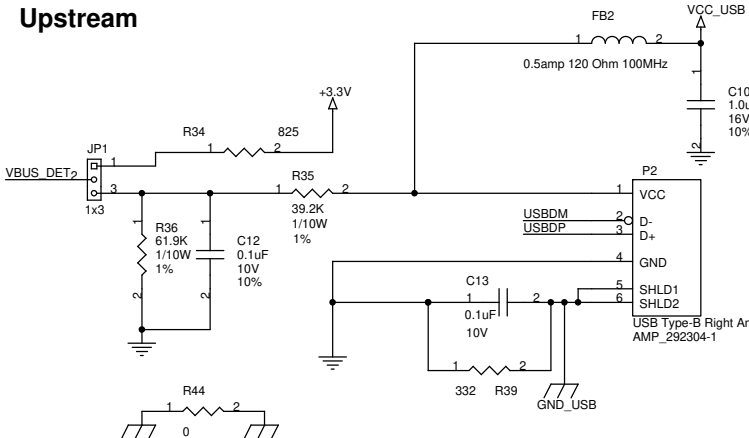

Input Power

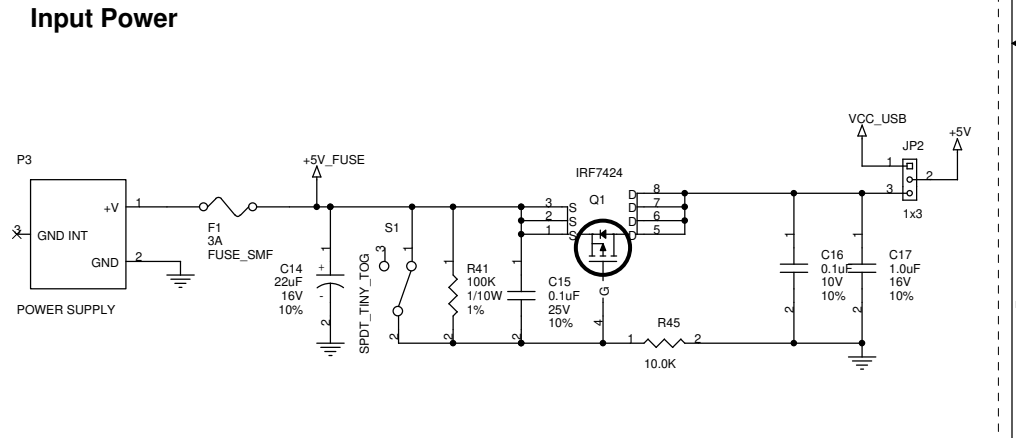

Power Supply Filtering

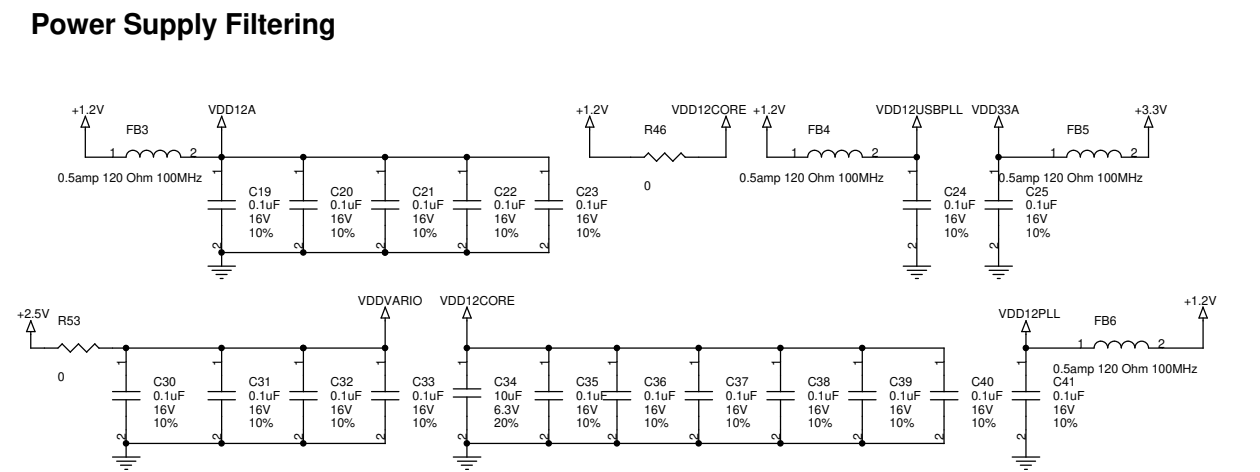

Power

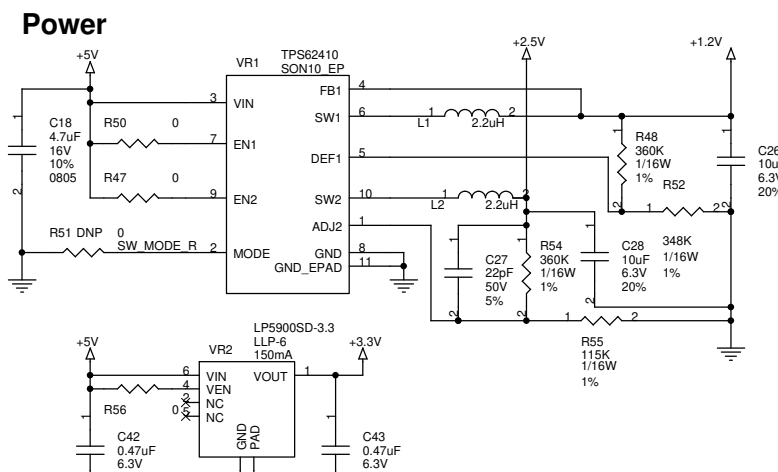

uWire EEPROM

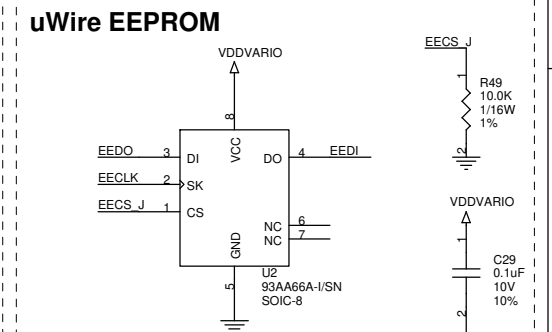

Title			
LAN7500, Ethernet, USB, Magnetics, EEPROM, Power			
Size	Engineer	Assembly No.	PCB Rev
C	R. W.	6588	A
Date:	Wednesday, November 04, 2009		Sheet 2 of 2