

THIS DRAWING IS UNPUBLISHED. RELEASED FOR PUBLICATION
 © COPYRIGHT 19 BY AMP INCORPORATED. ALL RIGHTS RESERVED.

LOC		DIST		REVISIONS			
P	LTR	DESCRIPTION		DATE	DWN	APVD	
FT	60	A		REV & REDRAW ON CAD PER EC 0320-70-97	11 MAR 97	-	-

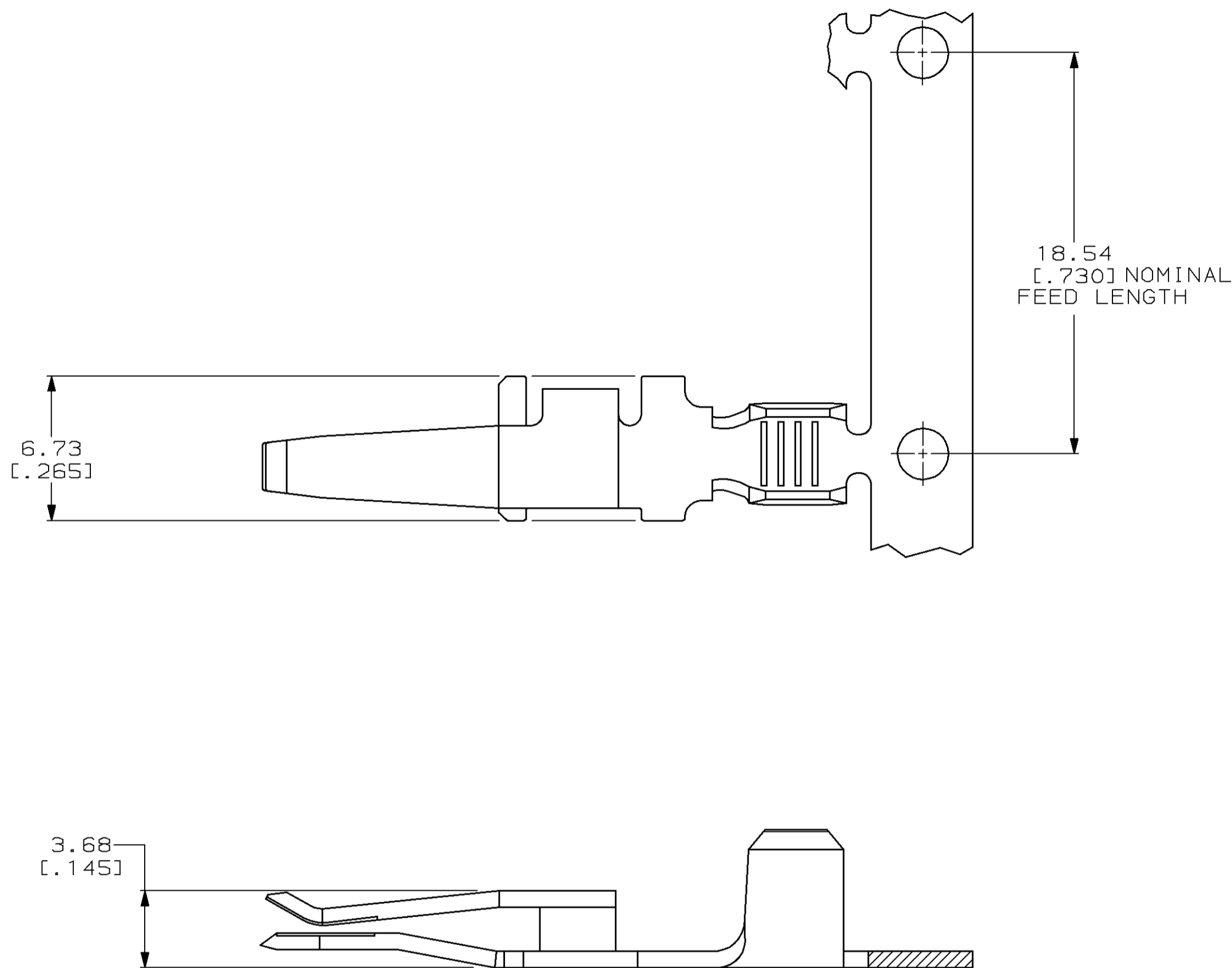

- ① ALL DIMENSIONS ARE MAXIMUM UNLESS OTHERWISE SPECIFIED.
- ② COPPER ALLOY.
- ③ 2.54µm [.000100] MIN TIN.
- 4. WIRE BARREL WILL ACCEPT ONE 10 OR 12 AWG STRANDED WIRE OR COMBINATIONS OF 12,18,16 AND 14 AWG WIRE.
- 5. THIS TERMINAL IS USED WITH HOUSING 556137 AND MOUNTING ADAPTER 557313-1.
- 6. APPLICATOR REEL: 567256-3 FOR "T" TERMINATOR, 567256-4 FOR AMP-O-ELECTRIC™ MODEL "K" MACHINE 565435-5.
- 7. HAND TOOL-LOOSE PIECE.

PACKAGING	DESCRIPTION	PART NUMBER
200 TERMINALS PER BOX	LOOSE PIECE	556136-2
2000 TERMINALS ON 24" DIA REEL	ON STRIP	556136-1

THIS DRAWING IS A CONTROLLED DOCUMENT.		DWN M. BINNER 11 MAR 97	AMP Incorporated Harrisburg, PA 17105-3608	
DIMENSIONS: mm [INCHES]		CHK R. STONE 14 MAR 97	NAME	
TOLERANCES UNLESS OTHERWISE SPECIFIED:		APVD M. McALONIS 17 MAR 97	PRODUCT SPEC	
0 PLC ±-	①	108-1373		
1 PLC ±-		APPLICATION SPEC		
2 PLC ±-		114-6051		
3 PLC ±-		WEIGHT		
4 PLC ±-		-		
ANGLES ±-		SIZE A2		
MATERIAL ②	FINISH ③	CAGE CODE 00779		
CUSTOMER DRAWING		DRAWING NO C-556136		
		SCALE 5:1 SHEET 1 OF 1 REV A		

556136