

March 1993

Video Operational Amplifier

Features

- Gain Bandwidth 50MHz
- High Slew Rate 150V/ μ s
- Low Supply Current 10mA
- Differential Gain Error 0.03%
- Differential Phase Error 0.03 Degree
- Gain Flatness at 10MHz 0.12dB

Applications

- Video Systems
- Video Test Equipment
- Radar Displays
- Data Acquisition Systems
- Imaging Systems
- Pulse Amplifiers
- Signal Conditioning Circuits

Description

The HA-2544 is a fast, unity gain stable, monolithic op amp designed to meet the needs required for accurate reproduction of video or high speed signals. It offers high voltage gain (6kV/V) and high phase margin (65 degrees) while maintaining tight gain flatness over the video bandwidth. Built from high quality Dielectric Isolation, the HA-2544 is another addition to the Harris series of high speed, wideband op amps, and offers true video performance combined with the versatility of an op amp.

The primary features of the HA-2544 include 50MHz Gain Bandwidth, 150V/ μ s slew rate, 0.03% differential gain error and gain flatness of just 0.12dB at 10MHz. High performance and low power requirements are met with a supply current of only 10mA.

Uses of the HA-2544 range from video test equipment, guidance systems, radar displays and other precise imaging systems where stringent gain and phase requirements have previously been met with costly hybrids and discrete circuitry. The HA-2544 will also be used in non-video systems requiring high speed signal conditioning such as data acquisition systems, medical electronics, specialized instrumentation and communication systems.

Military (/883) product and data sheets are available upon request.

Ordering Information

PART NUMBER	TEMP. RANGE	PACKAGE
HA2-2544-2	-55°C to +125°C	8 Pin TO-99 Can
HA2-2544-5	0°C to +75°C	8 Pin TO-99 Can
HA3-2544-5	0°C to +75°C	8 Lead Plastic DIP
HA3-2544C-5	0°C to +75°C	8 Lead Plastic DIP
HA4P2544-5	0°C to +75°C	20 Lead PLCC
HA4P2544C-5	0°C to +75°C	20 Lead PLCC
HA7-2544-2	-55°C to +125°C	8 Lead Ceramic DIP
HA7-2544-5	0°C to +75°C	8 Lead Ceramic DIP
HA9P2544-5	0°C to +75°C	8 Lead SOIC
HA9P2544-9	-40°C to +85°C	8 Lead SOIC
HA9P2544C-5	0°C to +75°C	8 Lead SOIC
HA9P2544C-9	-40°C to +85°C	8 Lead SOIC

Pinouts

HA-2544 (PDIP, CDIP, SOIC)
HA-2544C (PDIP, SOIC)
TOP VIEW

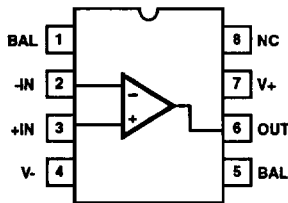

HA-2544/2544C (PLCC)
TOP VIEW

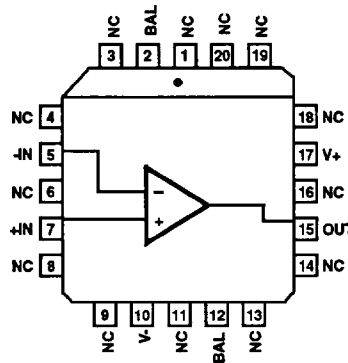

HA-2544 (TO-99 CAN)
TOP VIEW

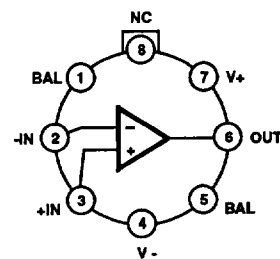

CAUTION: These devices are sensitive to electrostatic discharge. Users should follow proper I.C. Handling Procedures.
Copyright © Harris Corporation 1993

File Number 2900.1

Specifications HA-2544

Absolute Maximum Ratings (Note 1)

Voltage Between V+ and V- Terminals	35V
Differential Input Voltage (Note 11).....	6V
Peak Output Current	±40mA
Junction Temperature	+175°C
Junction Temperature (Plastic Package)	+150°C
Lead Temperature (Soldering 10 Sec.)	+300°C

Operating Conditions

Operating Temperature Range	0°C ≤ T _A ≤ +75°C
HA-2544/2544C-5	-40°C ≤ T _A ≤ +85°C
HA-2544-9	-55°C ≤ T _A ≤ +125°C
HA-2544-2	-65°C ≤ T _A ≤ +150°C
Storage Temperature Range	-65°C ≤ T _A ≤ +150°C

CAUTION: Stresses above those listed in "Absolute Maximum Ratings" may cause permanent damage to the device. This is a stress only rating and operation of the device at these or any other conditions above those indicated in the operational sections of this specification is not implied.

Electrical Specifications V_S = ±15V, C_L ≤ 10pF, R_L = 1kΩ, Unless Otherwise Specified

PARAMETER	TEMP	HA-2544-2/-5			HA-2544C-5			UNITS	
		MIN	TYP	MAX	MIN	TYP	MAX		
INPUT CHARACTERISTICS									
Offset Voltage	+25°C	-	6	15	-	15	25	mV	
	-2, -5	-	-	20	-	-	40	mV	
	-9	-	-	25	-	-	40	mV	
Average Offset Voltage Drift (Note 9)	Full	-	10	-	-	10	-	μV/°C	
Bias Current	+25°C	-	7	15	-	9	18	μA	
	Full	-	-	20	-	-	30	μA	
Average Bias Current Drift (Note 9)	Full	-	0.04	-	-	0.04	-	μA/°C	
Offset Current	+25°C	-	0.2	2	-	0.8	2	μA	
	Full	-	-	3	-	-	3	μA	
Offset Current Drift	Full	-	10	-	-	10	-	nA/°C	
Common Mode Range	Full	±10	±11.5	-	±10	±11.5	-	V	
Differential Input Resistance	+25°C	50	90	-	50	90	-	kΩ	
Differential Input Capacitance	+25°C	-	3	-	-	3	-	pF	
Input Noise Voltage (f = 1kHz)	+25°C	-	20	-	-	20	-	nV/√Hz	
Input Noise Current (f = 1kHz)	+25°C	-	2.4	-	-	2.4	-	pA/√Hz	
Input Noise Voltage	0.1Hz to 10Hz (Note 9)	+25°C	-	1.5	-	-	1.5	-	μV _{p,p}
	0.1Hz to 1MHz	+25°C	-	4.6	-	-	4.6	-	μV _{RMS}
TRANSFER CHARACTERISTICS									
Large Signal Voltage Gain (Notes 4, 9)	+25°C	3.5	6	-	3	6	-	kV/V	
	Full	2.5	-	-	2	-	-	kV/V	
Common Mode Rejection Ratio (Notes 6, 9)	-2, -5	75	89	-	70	89	-	dB	
	-9	75	89	-	65	89	-	dB	
Minimum Stable Gain	+25°C	+1	-	-	+1	-	-	V/V	
Unity Gain Bandwidth (Notes 3, 9)	+25°C	-	45	-	-	45	-	MHz	
Gain Bandwidth Product (Notes 3, 9)	+25°C	-	50	-	-	50	-	MHz	
Phase Margin	+25°C	-	65	-	-	65	-	Degrees	
OUTPUT CHARACTERISTICS									
Output Voltage Swing	Full	±10	±11	-	±10	±11	-	V	
Full Power Bandwidth (Note 7)	+25°C	3.2	4.2	-	3.2	4.2	-	MHz	
Peak Output Current (Note 9)	+25°C	±25	±35	-	±25	±35	-	mA	
Continuous Output Current (Note 9)	+25°C	±10	-	-	±10	-	-	mA	
Output Resistance (Open Loop)	+25°C	-	20	-	-	20	-	Ω	

2
OPERATIONAL
AMPLIFIERS

Specifications HA-2544

Electrical Specifications $V_S = \pm 15V$, $C_L \leq 10pF$, $R_L = 1k\Omega$, Unless Otherwise Specified (Continued)

PARAMETER	TEMP	HA-2544-2/-5			HA-2544C-5			UNITS
		MIN	TYP	MAX	MIN	TYP	MAX	
TRANSIENT RESPONSE								
Rise Time (Note 3)	+25°C	-	7	-	-	7	-	ns
Overshoot (Note 3)	+25°C	-	10	-	-	10	-	%
Slew Rate	+25°C	100	150	-	100	150	-	V/ μ s
Settling Time (Note 5)	+25°C	-	120	-	-	120	-	ns
VIDEO PARAMETERS $R_L = 1k\Omega$ (Note 10)								
Differential Phase (Note 12)	+25°C	-	0.03	-	-	0.03	-	Degree
Differential Gain (Notes 2, 12)	+25°C	-	0.0026	-	-	0.0026	-	dB
	+25°C	-	0.03	-	-	0.03	-	%
Gain Flatness								
	5MHz	+25°C	-	0.10	-	-	0.10	-
10MHz	+25°C	-	0.12	-	-	0.12	-	dB
Chrominance to Luminance Gain (Note 13)	+25°C	-	0.1	-	-	0.1	-	dB
Chrominance to Luminance Delay (Note 13)	+25°C	-	7	-	-	7	-	ns
POWER SUPPLY CHARACTERISTICS								
Supply Current	Full	-	10	12	-	10	15	mA
Power Supply Rejection Ratio (Notes 8, 9)	-2, -5	70	80	-	70	80	-	dB
	-9	65	80	-	65	80	-	dB

NOTES:

- Absolute maximum ratings are limiting values, applied individually beyond which the serviceability of the circuit may be impaired. Functional operability under any of these conditions is not necessarily implied.
- $$A_D(\%) = \left[10^{\frac{A_D(\text{dB})}{20}} - 1 \right] \times 100$$
- $V_{OUT} = \pm 100mV$. For Rise Time and Overshoot testing, V_{OUT} is measured from 0 to +200mV and 0 to -200mV.
- $V_{OUT} = \pm 5V$
- Settling Time is specified to 0.1% of final value for a 10V step and $A_V = -1$.
- $\Delta V_{CM} = \pm 10V$
- Full Power Bandwidth is guaranteed by equation: Full Power Bandwidth = $\frac{\text{Slew Rate}}{2\pi V_{PEAK}}$ ($V_{PEAK} = 5V$).
- $\Delta V_S = \pm 10$ to $\pm 20V$
- Refer to typical performance curve in Data Sheet.
- The video parameter specifications will degrade as the output load resistance decreases.
- To achieve optimum AC performance, the input stage was designed without protective diode clamps. Exceeding the maximum differential input voltage results in reverse breakdown of the base-emitter junction of the input transistors and probable degradation of the input parameters especially V_{OS} , I_{OS} and Noise.
- Tested with a VM700A video tester, using a NTC-7 Composite input signal. For adequate test repeatability, a minimum warm-up of 2 minutes is suggested. $A_V = +1$.
- C-L Gain and C-L Delay was less than the resolution of the test equipment used which is 0.1dB and 7ns, respectively.

Schematic

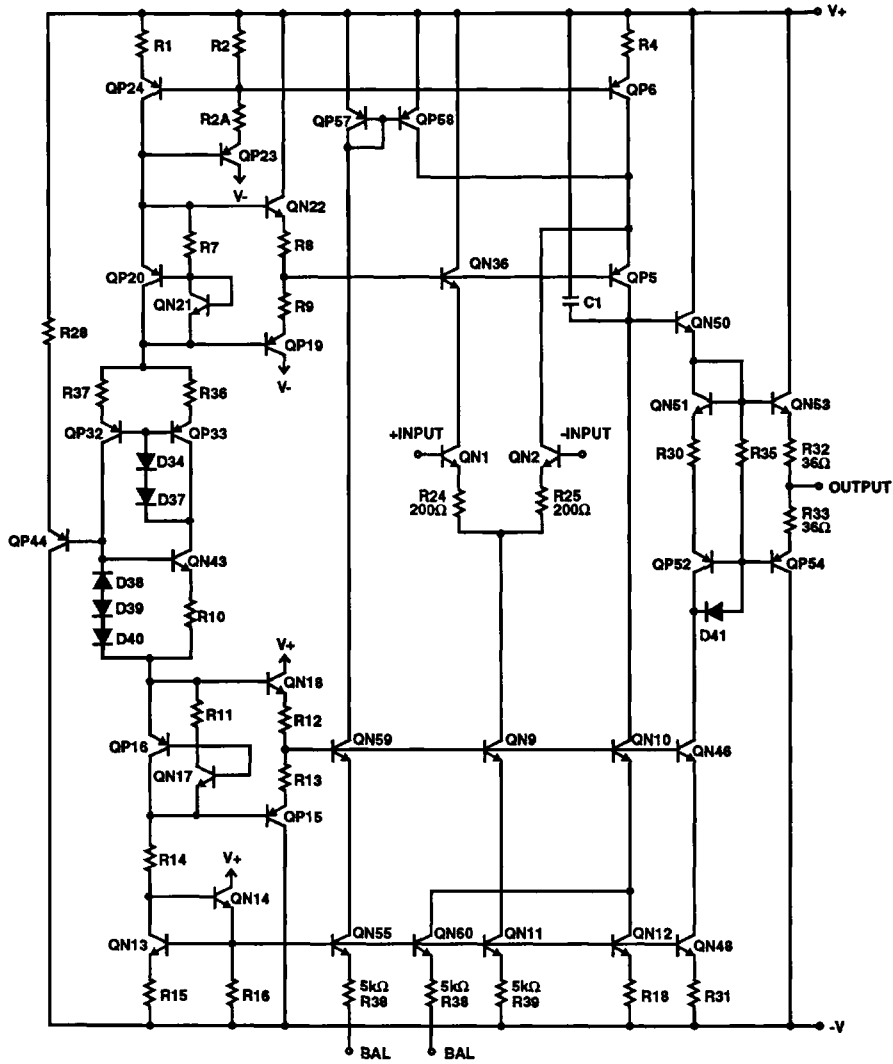

Die Characteristics

Transistor Count	44
Die Dimensions	80 x 65 x 19 mils
Substrate Potential*	V-
Process	High Frequency Bipolar D.I.
Passivation	Nitride

Thermal Constants (°C/W)	θ_{JA}	θ_{JC}
Metal Can	111	34
Plastic Mini-DIP	92	30
Ceramic Mini-DIP	114	35
SOIC	157	43
PLCC	74	33

* The substrate may be left floating (Insulating Die Mount) or it may be mounted on a conductor at V- potential.

Test Circuits

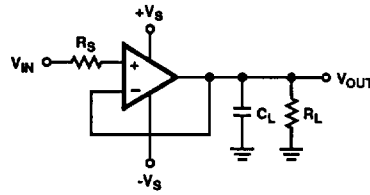

$V_S = \pm 15V$
 $A_V = +1$
 $R_S = 50\Omega$ or 75Ω (Optional)
 $R_L = 1k\Omega$
 $C_L < 10pF$
 V_{IN} for Large Signal = $\pm 5V$
 V_{IN} for Small Signal = 0 to +200mV and 0 to -200mV

FIGURE 1. TRANSIENT RESPONSE

LARGE SIGNAL RESPONSE

$V_{OUT} = 0$ to $+10V$
 Vertical Scale: ($V_{IN} = 5V/Div.$; $V_{OUT} = 2V/Div.$)
 Horizontal Scale: (100ns/Div.)

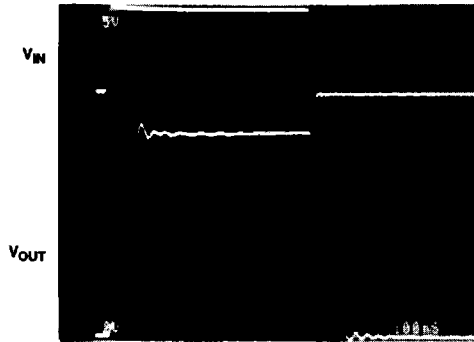

SMALL SIGNAL RESPONSE

$V_{OUT} = 0$ to $+200mV$
 Vertical Scale: ($V_{IN} = 100mV/Div.$; $V_{OUT} = 100mV/Div.$)
 Horizontal Scale: (100ns/Div.)

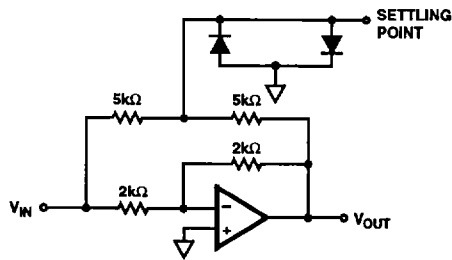
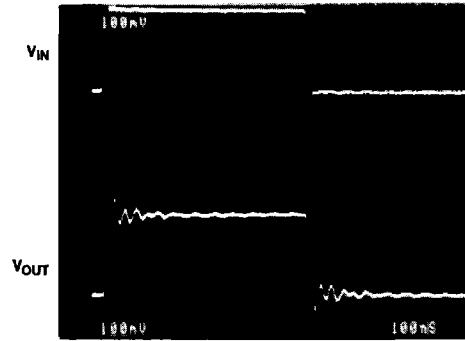

- $A_V = -1$
- Feedback and summing resistor ratios should be 0.1% matched.
- HP5082-2810 clipping diodes recommended.
- Tektronix P6201 FET probe used at settling point.

FIGURE 2. SETTLING TIME TEST CIRCUIT

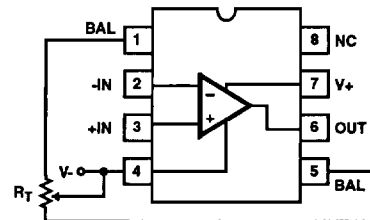

Tested offset adjustment range is $IV_{OS} + 1mV$ minimum referred to output. Typical range for $R_T = 20k\Omega$ is approximately $\pm 30mV$.

FIGURE 3. OFFSET VOLTAGE ADJUSTMENT

Typical Performance Curves

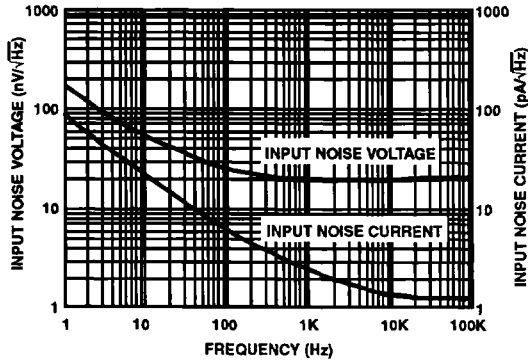

FIGURE 4. INPUT NOISE VOLTAGE AND NOISE CURRENT vs FREQUENCY

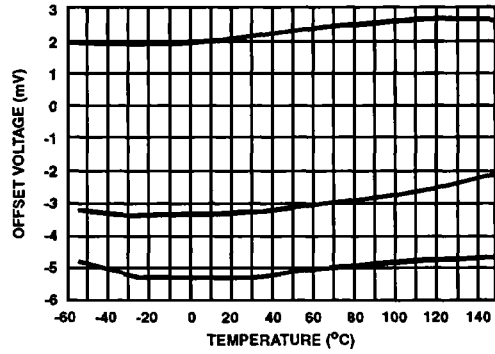
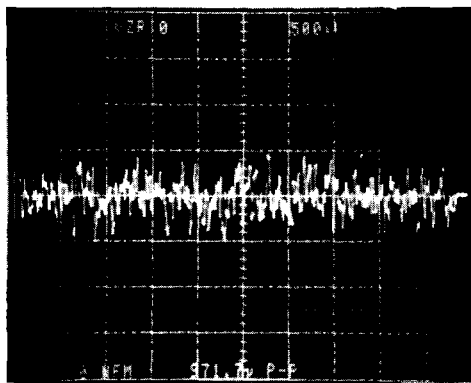

FIGURE 5. INPUT OFFSET VOLTAGE vs TEMPERATURE (3 TYPICAL UNITS)



0.1Hz to 10Hz, Noise Voltage = $0.97 \mu V_{p-p}$

FIGURE 6. NOISE VOLTAGE ($A_v = 1000$)

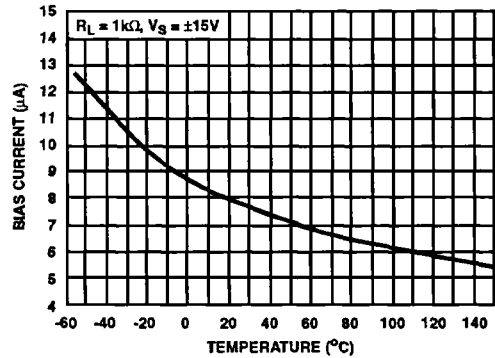

FIGURE 7. INPUT BIAS CURRENT vs TEMPERATURE

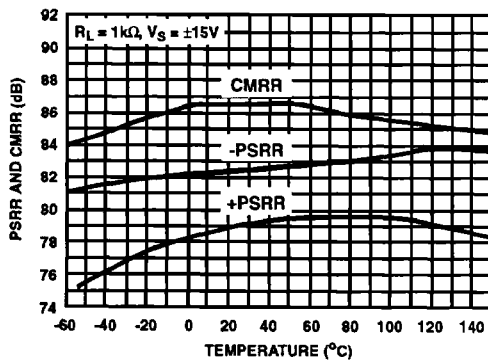

FIGURE 8. PSRR AND CMRR vs TEMPERATURE

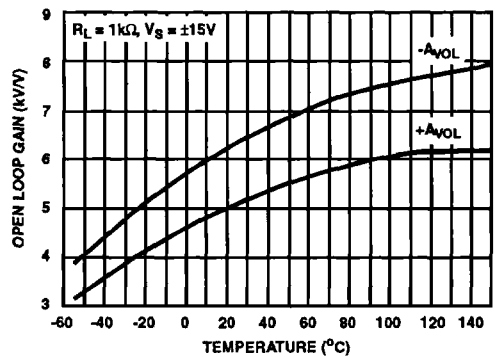

FIGURE 9. OPEN LOOP GAIN vs TEMPERATURE

Typical Performance Curves (Continued)

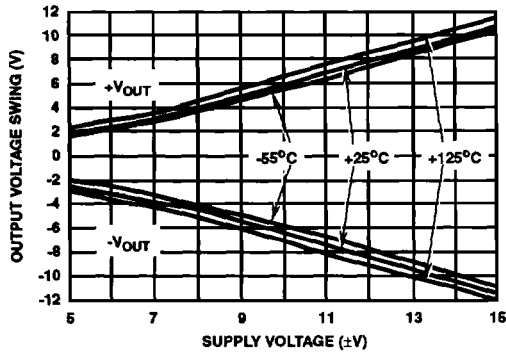

FIGURE 10. OUTPUT VOLTAGE SWING vs SUPPLY VOLTAGE (OVER FULL TEMPERATURE)

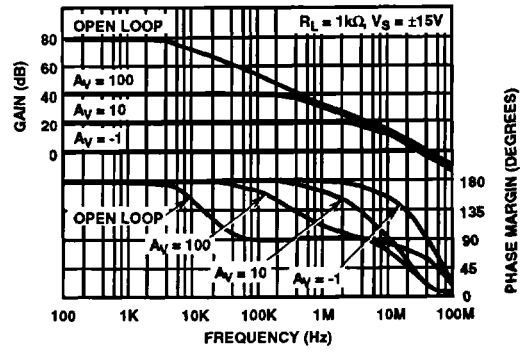

FIGURE 11. FREQUENCY RESPONSE AT VARIOUS GAINS

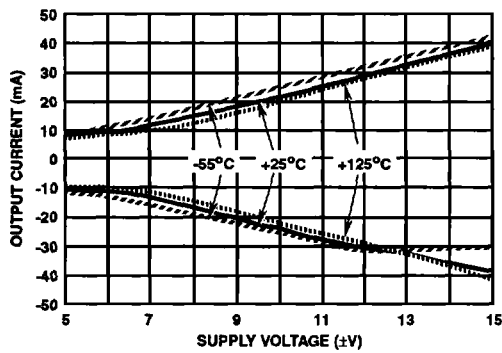

FIGURE 12. OUTPUT CURRENT vs SUPPLY VOLTAGE (OVER FULL TEMPERATURE)

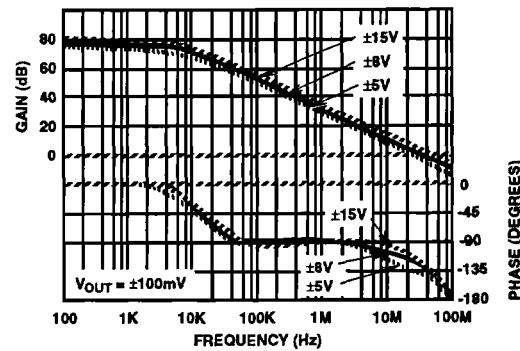

FIGURE 13. OPEN LOOP RESPONSE

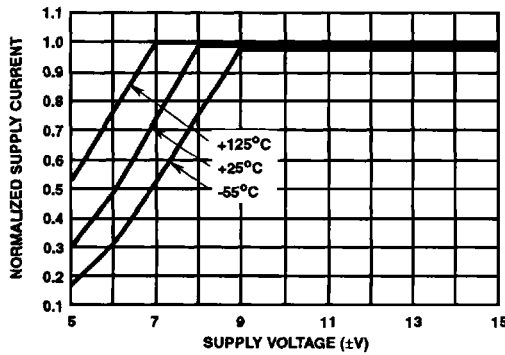

FIGURE 14. SUPPLY CURRENT vs SUPPLY VOLTAGE (NORMALIZED AT $V_S = \pm 15V$ AT $+25^\circ C$)

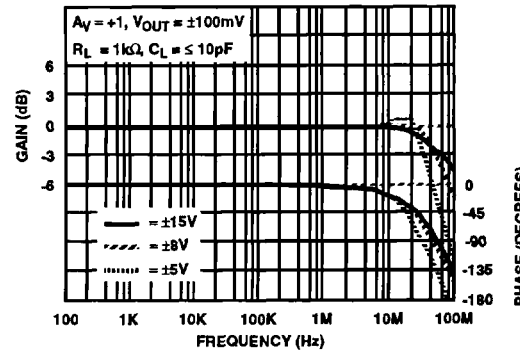

FIGURE 15. VOLTAGE FOLLOWER RESPONSE

Typical Video Performance Curves

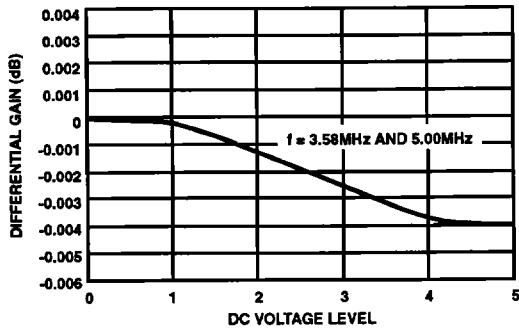

FIGURE 16. AC GAIN VARIATION vs DC OFFSET LEVELS (DIFFERENTIAL GAIN)

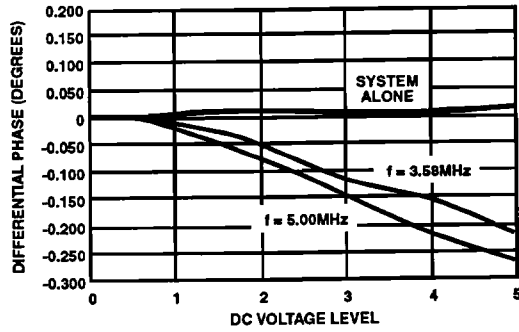
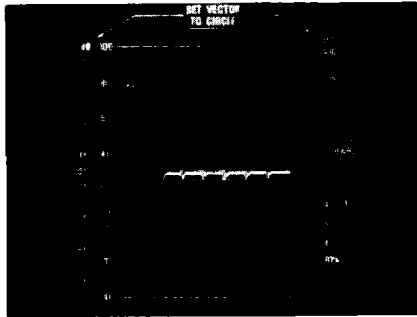
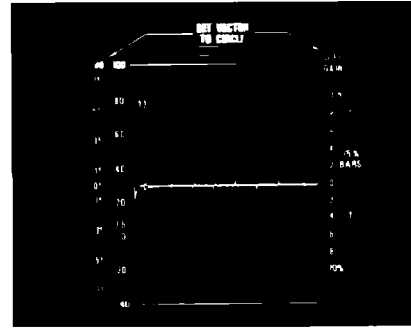

FIGURE 17. AC PHASE VARIATION vs DC OFFSET LEVELS (DIFFERENTIAL PHASE)



NTSC Method, $R_L = 1k\Omega$, Differential Gain $< 0.05\%$ at $T_A = +75^\circ C$
No Visual Difference at $T_A = -55^\circ C$ or $+125^\circ C$

FIGURE 18. DIFFERENTIAL GAIN



NTSC Method, $R_L = 1k\Omega$, Differential Phase < 0.05 Degree at $T_A = +75^\circ C$
No Visual Difference at $T_A = -55^\circ C$ or $+125^\circ C$

FIGURE 19. DIFFERENTIAL PHASE

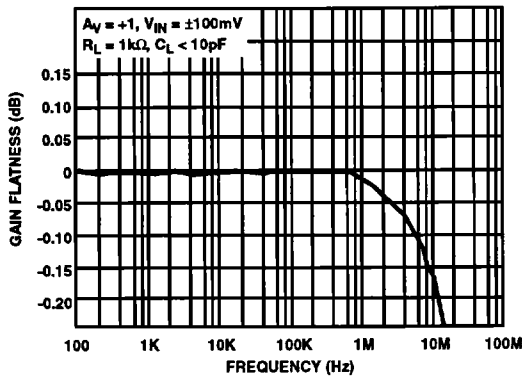
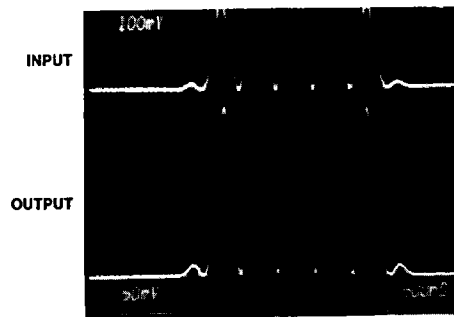

FIGURE 20. GAIN FLATNESS



NTSC Method, $R_L = 1k\Omega$, C-L Delay $< 7ns$ at $T_A = +75^\circ C$
No Visual Difference at $T_A = -55^\circ C$ or $+125^\circ C$

Vertical Scale: Input = 100mV/Div., Output = 50mV/Div.
Horizontal Scale: 500ns/Div.

FIGURE 21. CHROMINANCE TO LUMINANCE DELAY

Typical Video Performance Curves (Continued)

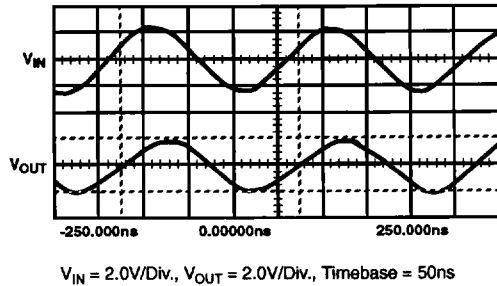

FIGURE 22. $\pm 2V$ OUTPUT SWING (WITH $R_{LOAD} = 75\Omega$, FREQUENCY = 5.00MHz)

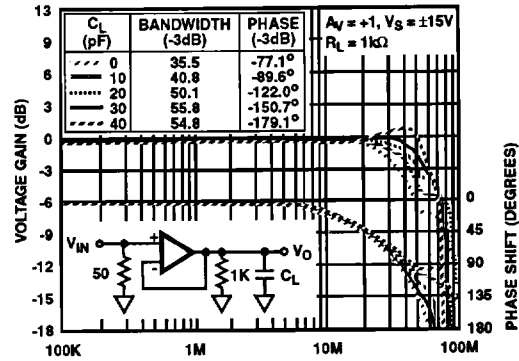

FIGURE 23. BANDWIDTH vs LOAD CAPACITANCE

Applications and Product Guidelines

The HA-2544 is a true differential op amp that is as versatile as any op amp but offers the advantages of high unity gain bandwidth, high speed and low supply current. More important than its general purpose applications is that the HA-2544 was especially designed to meet the requirements found in a video amplifier system. These requirements include fine picture resolution and accurate color rendition, and must meet broadcast quality standards.

In a video signal, the video information is carried in the amplitude and phase as well as in the DC level. The amplifier must pass the 30Hz line rate luminance level and the 3.58MHz (NTSC) or 4.43MHz (PAL) color band without altering phase or gain. The HA-2544's key specifications aimed at meeting this include high bandwidth (50MHz), very low gain flatness (0.12dB at 10MHz), near unmeasurable differential gain and differential phase (0.03% and 0.03 degrees), and low noise (20nV/ \sqrt{Hz}). The HA-2544 meets these guidelines.

The HA-2544 also offers the advantage of a full output voltage swing of $\pm 10V$ into a 1k Ω load. This equates to a full power bandwidth of 2.4MHz for this $\pm 10V$ signal. If video signal levels of $\pm 2V$ maximum is used (with $R_L = 1k\Omega$), the full power bandwidth would be 11.9MHz without clipping distortion. Another usage might be required for a direct 50 Ω or 75 Ω load where the HA-2544 will still swing this $\pm 2V$ signal as shown in the above display. One important note that must be realized is that as load resistance decreases the video parameters are also degraded. For optimal video performance a 1 k Ω load is recommended.

If lower supply voltages are required, such as $\pm 5V$, many of the characterization curves indicate where the parameters vary. As shown the bandwidth, slew rate and supply current are still very well maintained.

Prototyping and PC Board Layout

When designing with the HA-2544 video op amp as with any high performance device, care should be taken to use high frequency layout techniques to avoid unwanted parasitic effects. Short lead lengths, low source impedance and lower value feedback resistors help reduce unwanted poles or zeros. This layout would also include ground plane construction and power supply decoupling as close to the supply pins with suggested parallel capacitors of 0.1 μF and 0.001 μF ceramic to ground.

In the noninverting configuration, the amplifier is sensitive to stray capacitance (<40pF) to ground at the inverting input. Therefore, the inverting node connections should be kept to a minimum. Phase shift will also be introduced as load parasitic capacitance is increased. A small series resistor (20 Ω to 100 Ω) before the capacitance effectively decouples this effect.

Stability/Phase Margin/Compensation

The HA-2544 has not sacrificed unity gain stability in achieving its superb AC performance. For this device, the phase margin exceeds 60 degrees at the unity crossing point of the open loop frequency response. Large phase margin is critical in order to reduce the differential phase and differential gain errors caused by most other op amps. Because this part is unity gain stable, no compensation pin is brought out. If compensation is desired to reduce the noise bandwidth, most standard methods may be used. One method suggested for an inverting scheme would be a series R-C from the inverting node to ground which will reduce bandwidth, but not effect slew rate. If the user wishes to achieve even higher bandwidth (>50MHz), and can tolerate some slight gain peaking and lower phase margin, experimenting with various load capacitance can be done.

Shown in Application 1 is an excellent Differential Input, Unity Gain Buffer which also will terminate a cable to 75 Ω and reject common mode voltages. Application 2 is a method of separating a video signal up into the Sync. only signal and the Video and Blanking signal. Application 3 shows the HA-2544 being used as a 100kHz High Pass 2-Pole Butterworth Filter. Also shown is the measured frequency response curves.

Typical Applications

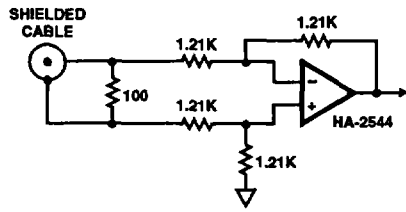

FIGURE 24. APPLICATION 1, 75Ω DIFFERENTIAL INPUT BUFFER

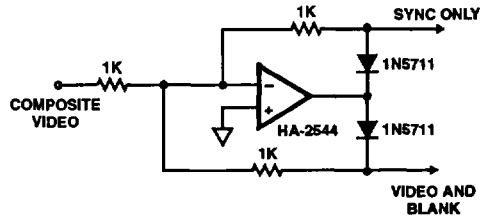

FIGURE 25. APPLICATION 2, COMPOSITE VIDEO SYNC SEPARATOR

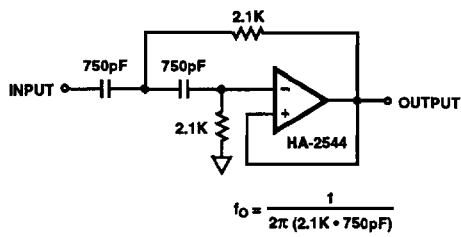

FIGURE 26. APPLICATION 3, 100kHz HIGH PASS 2-POLE BUTTERWORTH FILTER

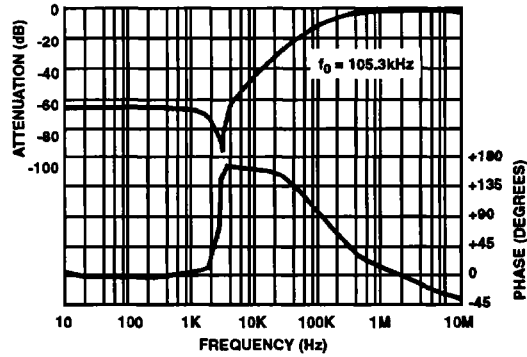

FIGURE 27. MEASURED FREQUENCY RESPONSE OF APPLICATION 3