

LOC	DIST	REVISIONS					
		P.	LTN	DESCRIPTION	DATE	DWN	APVD
CM	00						
		C1		REVISED PER ECO-06-016350	28AUG2006	KW	SR
		C2		REVISED PER ECO-18-009739	20JUN2018	BKW	SF

- △ SHEET METAL SCREWS NOT SUPPLIED.
- △ INSERT IS ATTACHED TO STRAIN RELIEF AS AN ADDITIONAL ADJUSTMENT FOR SMALL WIRE BUNDLES. IT SHOULD BE CUT OFF AND POSITIONED AS SHOWN.
- △ TWO REQUIRED PER CONNECTOR.
- 4. DETACHABLE INSERT MAY SEPARATE FROM STRAIN RELIEF BODY DURING SHIPPING.

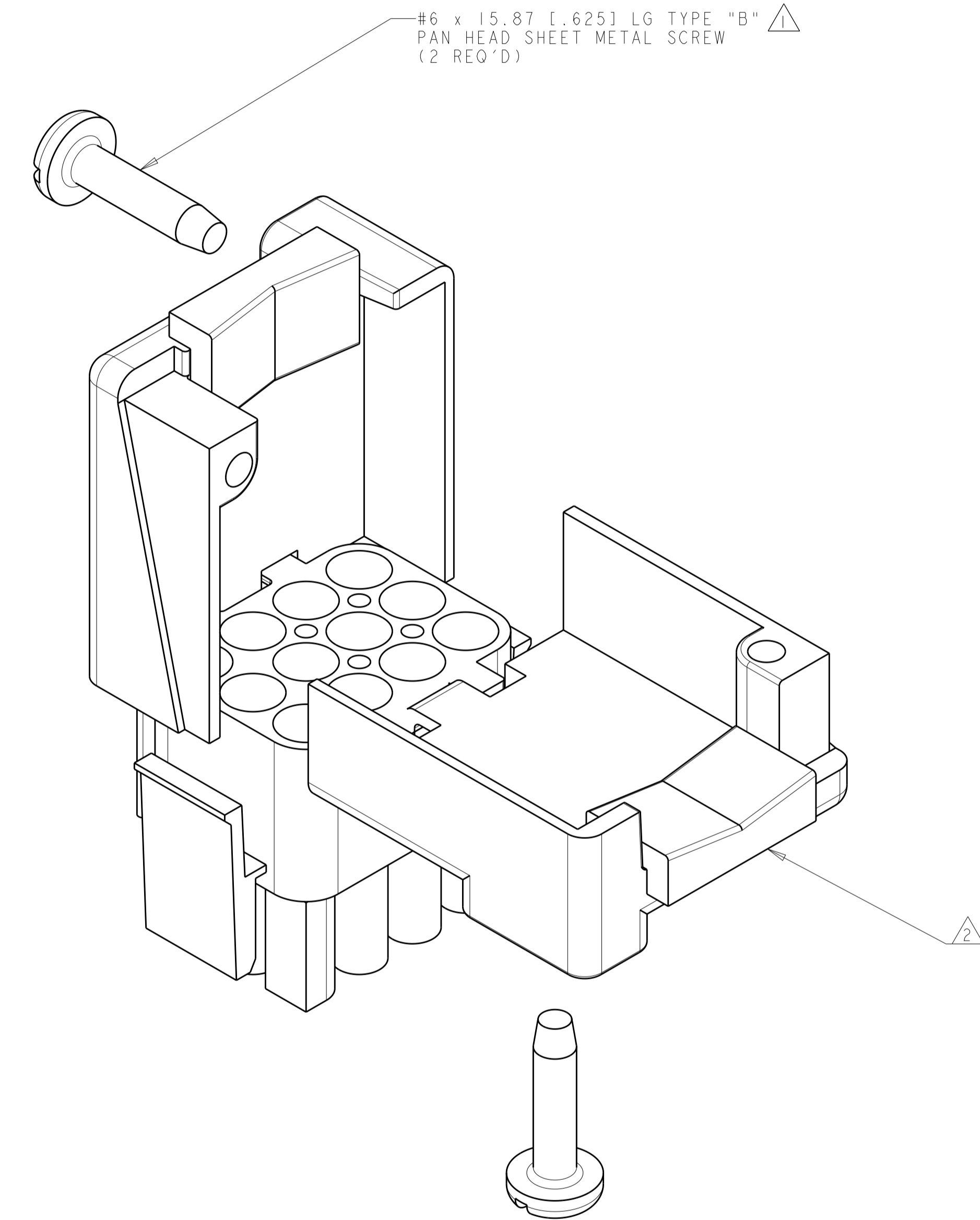
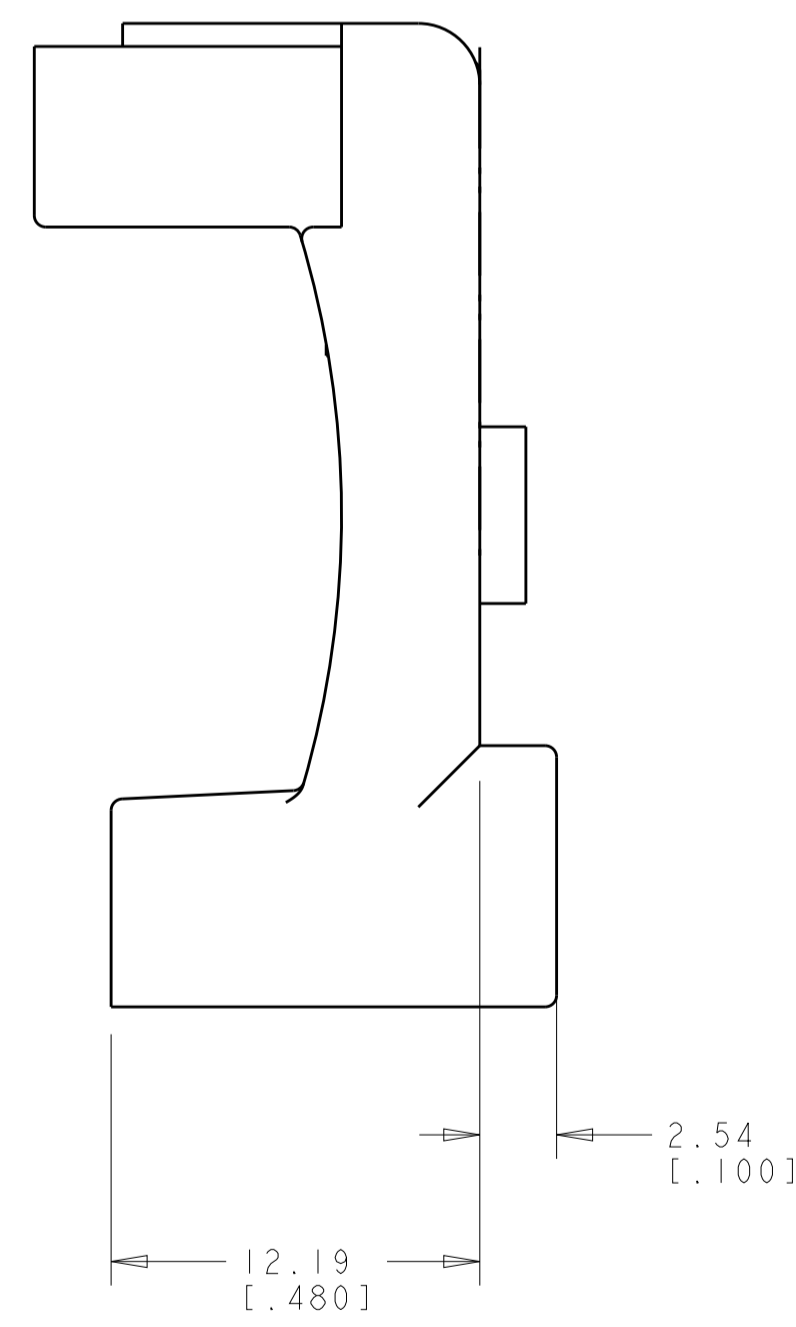
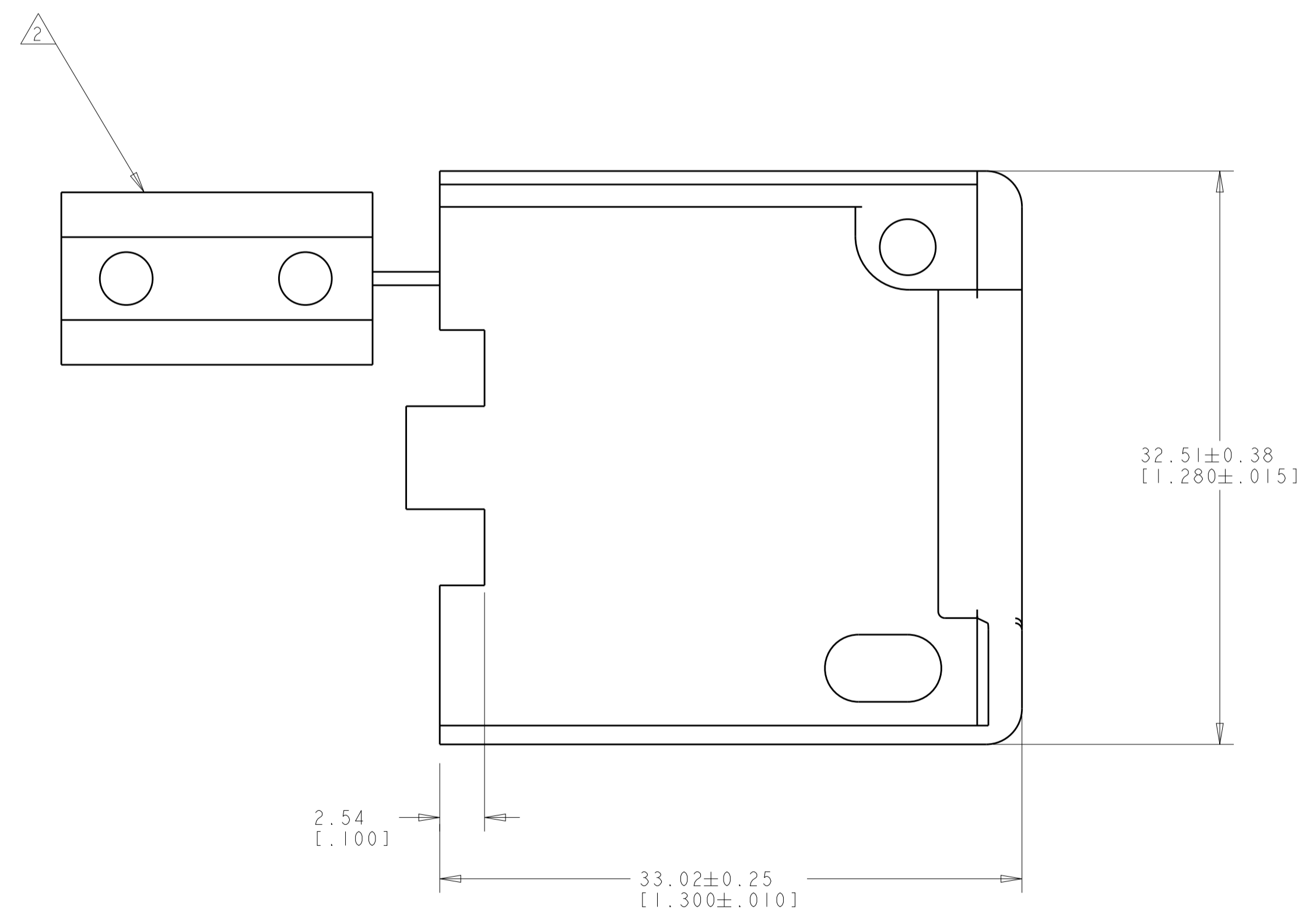
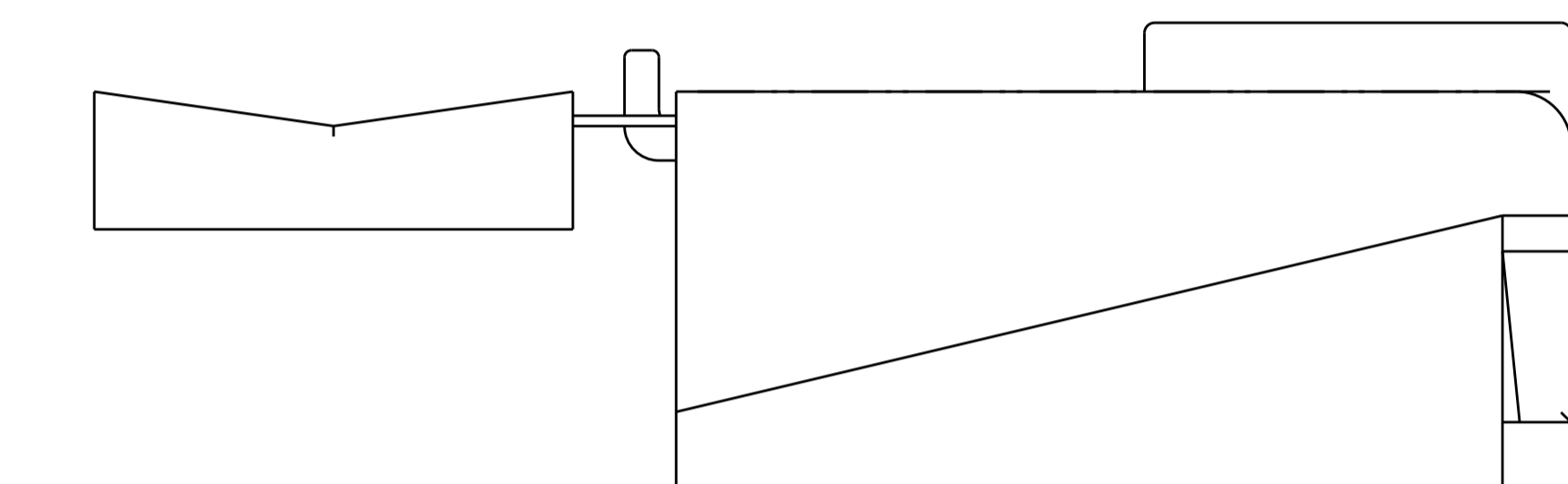

	WIRE BUNDLE DIAMETER
WITHOUT INSERT	19.05 [.750] MAX
WITH INSERT	3.81 [.150] MAX

COLOR	MATERIAL	PART NUMBER
BLACK	NYLON UL94V-0	640717-2 △3
NATURAL	NYLON UL94V-0	640717-1 △3

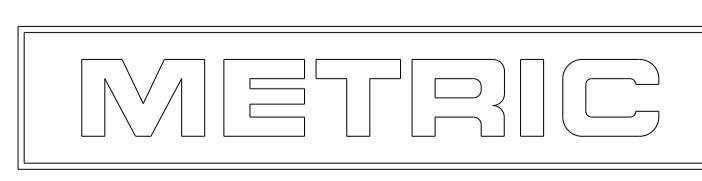

DIMENSIONS: mm [INCHES] TOLERANCES UNLESS OTHERWISE SPECIFIED: 0 PLC ± 1 PLC ±.013 [.005] 2 PLC ± 3 PLC ± 4 PLC ± ANGLES ±40°/30° FINISH -		DWN K. WHITAKER 28AUG2006 CHK S. RIDGILL 28AUG2006 APVD S. RIDGILL 28AUG2006 PRODUCT SPEC APPLICATION SPEC WEIGHT - CUSTOMER DRAWING	Tyco Electronics Harrisburg, PA 17105-3608 NAME STRAIN RELIEF AND INSERT, 12 CIRCUIT, UNIVERSAL MATE-N-LOK(TM) SIZE A1 CAGE CODE 00779 DRAWING NO. 640717 SCALE 4:1 SHEET 1 OF 1 REV C2
--	--	--	---