

TO: \_\_\_\_\_

SPEC No. | EL19Y048

ISSUE: Nov. 26 2007

# SPECIFICATIONS

Product Type 16-bit LED panel driver

Model No. IR2D07  
(IR2D071)

\* This specifications contains 21 pages including the cover and appendix.

CUSTOMERS  
ACCEPTANCE

DATE: \_\_\_\_\_

BY: \_\_\_\_\_

PRESENTED

BY: H. Fujita

H. Fujita

Dept. General Manager

REVIEWED

BY:

K. Kojima

PREPARED

BY:

A. Kamura

Development Dept.  
Analog Device Buisness Promotion Center  
System-Flash Division  
Large-Scale IC Group  
SHARP CORPORATION

- Handle this document carefully for it contains material protected by international copyright law. Any reproduction, full or in part, of this material is prohibited without the express written permission of the company.
  
  - When using the products covered herein, please observe the conditions written herein and the precautions outlined in the following paragraphs. In no event shall the company be liable for any damages resulting from failure to strictly adhere to these conditions and precautions.
- (1) The products covered herein are designed and manufactured for the following application areas. When using the products covered herein for the equipment listed in Paragraph (2), even for the following application areas, be sure to observe the precautions given in Paragraph (2). Never use the products for the equipment listed in Paragraph (3).
- Office electronics
  - Instrumentation and measuring equipment
  - Machine tools
  - Audiovisual equipment
  - Home appliances
  - Communication equipment other than for trunk lines.
- (2) Those contemplating using the products covered herein for the following equipment which demands high reliability, should first contact a sales representative of the company and then accept responsibility for incorporating into the design fail-safe operation, redundancy, and other appropriate measures for ensuring reliability and safety of the equipment and the overall system.
- Control and safety devices for airplanes, trains, automobiles, and other transportation equipment
  - Mainframe computers
  - Traffic control systems
  - Gas leak detectors and automatic cutoff devices
  - Rescue and security equipment
  - Other safety devices and safety equipment, etc.
- (3) Do not use the products covered herein for the following equipment which demands extremely high performance in terms of functionality, reliability, or accuracy.
- Aerospace equipment
  - Communications equipment for trunk lines
  - Control equipment for the nuclear power industry
  - Medical equipment related to life support, etc.
- (4) Please direct all queries and comments regarding the interpretation of the above three Paragraphs to a sales representative of the company.
- Please direct all queries regarding the products covered herein to a sales representative of the company.

## CONTENTS

	Page
1. General Description -----	2
2. Features -----	2
3. Block Diagram and Typical Application Circuit -----	2
4. Terminal Name -----	3
5. Terminal Connections -----	3
6. Equivalent Circuits for Inputs and Outputs -----	4
7. Function Description	
7-1. Terminal Description -----	5
7-2. Truth Table -----	5
7-3. Precautions -----	6
8. Absolute Maximum Ratings -----	7
9. Recommended Operating Conditions -----	7
10. Electrical Characteristics	
10-1. DC Electrical Characteristics -----	8
10-2. Switching Electrical Characteristics -----	8
10-3. AC Electrical Characteristics -----	9
11. Timing Waveform -----	10
12. Typical Characteristics -----	11
13. Application Circuit Example -----	12
14. Package Outline Specification -----	13

1. General Description

The Sharp IR2D07 is a current-sink constant current driver incorporating 16-bit shift register, 16-bit data-latch and a gate circuit. This driver is low power consumption and high accuracy current driving. This driver is designed for driving LEDs and LED displays.

2. Features

- Clock frequency :                   max. 20MHz (non cascade condition)  
  max. 16.6MHz (cascade condition)
- Constant current range :       2 to 60 mA  
  (can be set by one external resistor or one external constant current source)
- Input level :                       CMOS level
- Not designed or rated as radiation hardened.
- Package material: Plastic
- Chip material and wafer substrate type: P type silicon
- Number of pins and package type: 28pin SDIP
- Process Structure: Bi-CMOS
- Applications: LEDs, LED displays

3. Block Diagram and Typical Application Circuit

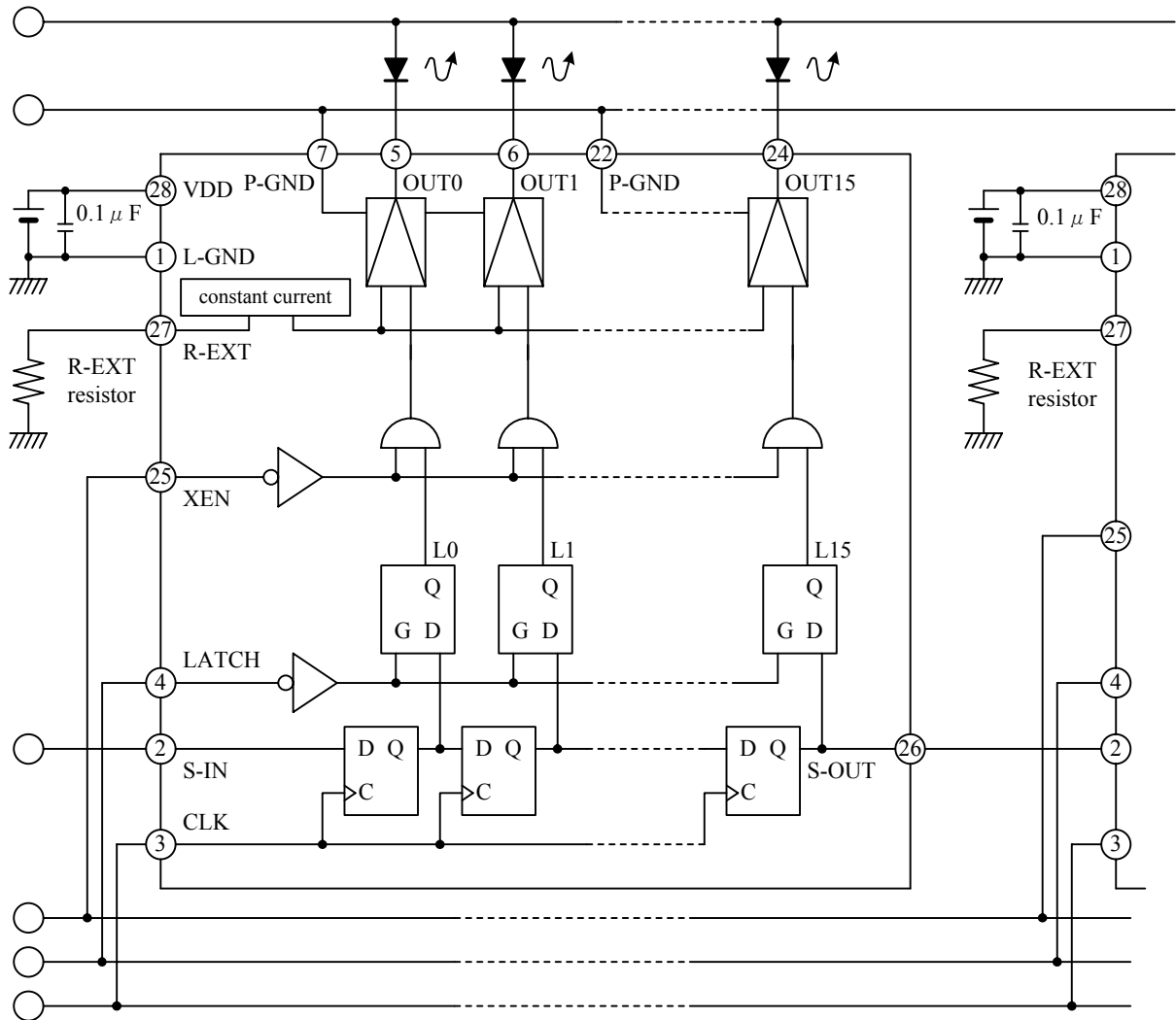

## 4. Terminal Name

Pin No.	Term. Name	Description
1	L-GND	Logic-ground
2	S-IN	Serial data input
3	CLK	Clock input
4	LATCH	Latch input
5	OUT0	Constant current output
6	OUT1	Constant current output
7	P-GND	Power-ground
8	OUT2	Constant current output
9	OUT3	Constant current output
10	OUT4	Constant current output
11	OUT5	Constant current output
12	P-GND	Power-ground
13	OUT6	Constant current output
14	OUT7	Constant current output
15	OUT8	Constant current output
16	OUT9	Constant current output
17	P-GND	Power-ground
18	OUT10	Constant current output
19	OUT11	Constant current output
20	OUT12	Constant current output
21	OUT13	Constant current output
22	P-GND	Power-ground
23	OUT14	Constant current output
24	OUT15	Constant current output
25	XEN	Output enable input
26	S-OUT	Serial data output
27	R-EXT	External resistor
28	VDD	Power supply

## 5. Terminal Connections

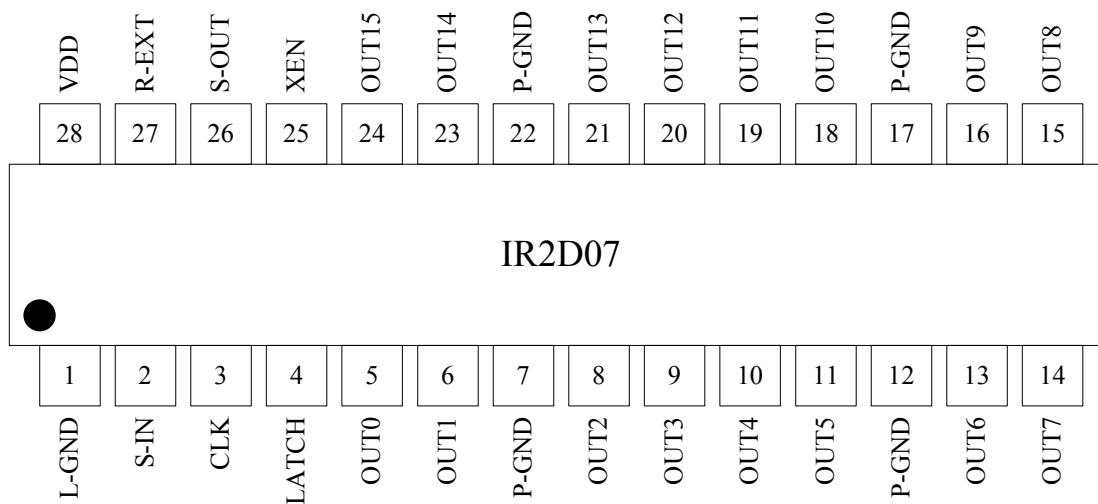

6. Equivalent Circuits for Inputs and Outputs

(a)CLK,S-IN

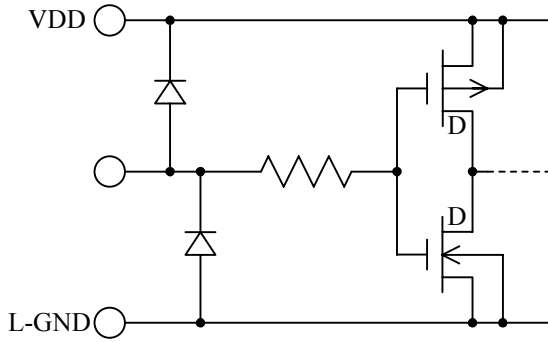

(b)LATCH,XEN

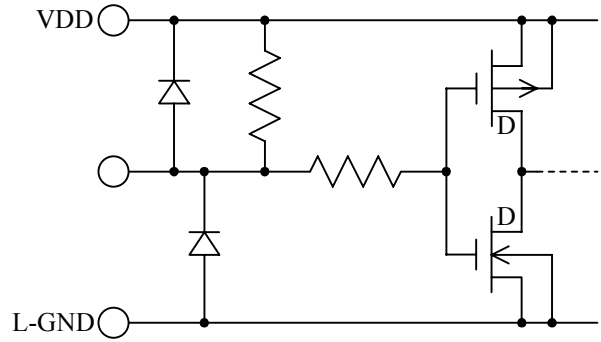

(c)S-OUT

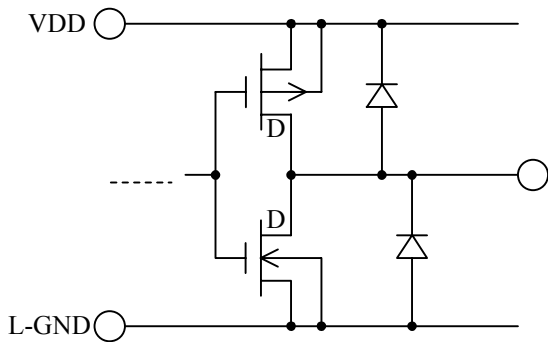

(d)OUTx

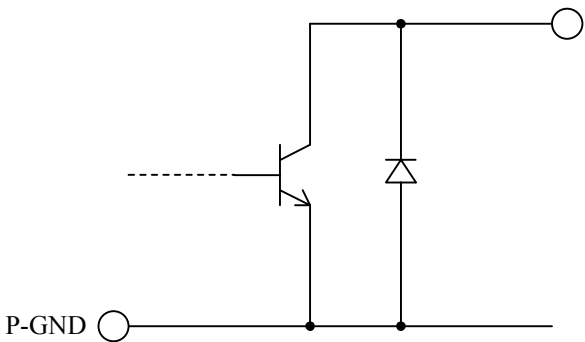

(e)R-EXT

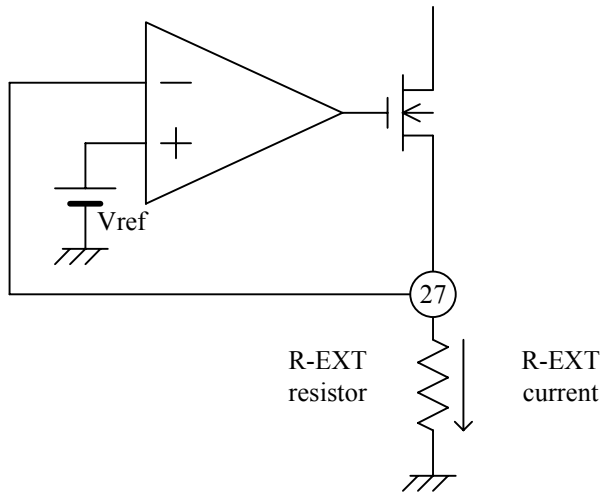

## 7. Functional Description

## 7-1 Terminal Description

Pin No.	Symbol	Description
1	L-GND	Ground terminal for logic and constant current control circuit
2	S-IN	Serial data input terminal
3	CLK	Clock input for shift register. The data in shift register is shifted synchronizing to the rising edge of CLK.
4	LATCH	Latch input. When this terminal goes low, the data on shift register goes through the latch . When this terminal goes high, the data is latched.
5, 6 8 ~ 11 13 ~ 16 18 ~ 21 23, 24	OUT0 ? OUT15	Constant current output terminal. This terminal is open collector output.
7, 12 17, 21	P-GND	Ground terminal for LED driver.
25	XEN	Input for output enable. When XEN goes high, all outputs of constant current driver goes off. When XEN goes low and data of latch (Ln) goes high, the corresponding outputs (OUTn) of constant current driver turns on.
26	S-OUT	Serial data output
27	R-EXT	Control terminal of constant current value . Output current (IOUT) is set by connecting one external resistor or one current source between R-EXT and GND. resistor: $IOUT[A] = (Vref / R-EXT \text{ resistor}) \times 200$ current source: $IOUT[A] = R-EXT \text{ current} \times 200$
28	VDD	Power supply for logic and constant current circuit

## 7-2 Truth Table

INPUT		OUTPUT
XEN	Ln	OUTn
L	L	OFF
L	H	ON
H	*	OFF

\*: Don't care

### 7-3 Precautions

- If the EXT terminal is shorted with other terminals, an excessive current might flow. Therefore the EXT terminal should not be shorted with other terminals.
- If R-EXT resistor is connected to Unstable GND potential, a constant current output terminal might oscillate. It is recommended that this terminal connected with the stable GND line.
- The power-on reset circuit is not built in IC, Therefore, the data of F/F for a latch is not decided when a power supply is turned on.
- Please be sure to connect L-GND and P-GND on the outside.
- It is recommended that the decoupling capacitor of 1uF or more between VDD and L-GND as much as possible near the IC terminal.
- Please do not open the constant current output terminals.
- Please adjust the voltage of the output terminal 0.6V or more when the LEDs are driven ( $I_{out} < 48.5\text{mA}$ )
- Please do not open the S-IN terminal and the CLK terminal .
- It is recommended that the LEDs are arrange near this IC, because operation may become unstable due to the electromagnetic interference caused by the wiring and something else.
- This application circuit example is a reference example and is not guaranteed its operation in all conditions. Be sure to check the operation of your circuits.
- Please do not exceed the absolute maximum rating in any case, including turning on and turning off the power.
- This device does not include protection circuits for over voltage, over current or over temperature. If protection is necessary, please protect on the control circuit side.



## 8. Absolute Maximum Ratings

(Ta=25°C)

Parameter	Symbol	Conditions	Rating	Unit
Supply voltage	VDD		7.0	V
Input voltage	V <sub>IN</sub>		-0.3 ~ VDD+0.3	V
Output current	I <sub>OUT</sub>		60	mA
Output voltage	V <sub>OUT</sub>		7.0	V
Power dissipation	Pd	Ta ≤ 25°C	1.35	W
Derating ratio	ΔPd/°C	Ta > 25°C	10.8	mW/°C
Operating temperature range	Topr		-40 ~ +100	°C
Storage temperature range	Tstg		-55 ~ +150	°C

## 9. Recommended Operating Conditions

(VDD=3.0 ~ 5.5V, Ta=-40 ~ 100°C)

Parameter		Symbol	Conditions	MIN.	TYP.	MAX.	Unit
Supply voltage		VDD		3.0	3.3	5.5	V
Output current	OUTn	I <sub>OUT</sub>	Duty 1/4	2.0	-	55.0	mA
	S-OUT	I <sub>OH</sub>		-	-	-1.0	
		I <sub>OL</sub>		-	-	1.0	
Input voltage		V <sub>IN</sub>		0.0	-	VDD	V
Clock frequency		f <sub>CLK</sub>		-	-	20	MHz
			Cascade Connected	-	-	16.6	

\* It is recommended the above-mentioned Recommended Operating Conditions.

When using it exceeding this condition, the reliability of this IC might be influenced harmfully.

## 1 0 . Electrical Characteristics

## 1 0 — 1 . D C Electrical Characteristics

( VDD=3.0 ~ 5.5V, Ta=-40 ~ 100°C )

Parameter	Symbol	Conditions	MIN.	TYP.	MAX.	Unit	
"H" Input voltage	V <sub>IH</sub>		0.7VDD	-	VDD	V	
"L" Input voltage	V <sub>IL</sub>		GND	-	0.3VDD		
S-OUT terminal	V <sub>OH</sub>	VDD=3.3V, I <sub>O H</sub> = -1.0mA	2.7	3.0	-	V	
Output voltage	V <sub>OL</sub>	VDD=3.3V, I <sub>O L</sub> = 1.0mA	-	0.3	0.6		
Output leakage current	I <sub>OLEAK</sub>	VO <sub>UT</sub> =7.0V, Per one terminal.	-	-	10	μA	
Output current	I <sub>OUT</sub>	VDD=3.3V R-EXT resistor = 5kΩ VO <sub>UT</sub> =0.6V	43.5	48.5	53.5	mA	
Error between bits	ΔI <sub>OL</sub>	Ta=25°C	-	1.0	4.0	±%	
R-EXT terminal voltage	V <sub>ref</sub>	R-EXT resistor=5kΩ	VDD=3.3V	1.18	1.24	1.30	V
Supply voltage regulation	ΔV <sub>ref</sub>	Ta=25°C	VDD=3.0V → 3.6V	-10	10	30	mV
Input Pull-Up resistor	R <sub>IN</sub>	LATCH, XEN	50	110	200	kΩ	
Supply current	IDD1	VDD=3.3V(Note 1) R-EXT resistor=5kΩ, CLK=0Hz	-	450	1500	μA	

Note 1 : Data is inputted so that all output terminals may be set to "ON", and XEN terminal = "H"

## 1 0 - 2 . Switching Characteristics

(VDD=3.0 ~ 5.5V, Ta=-40 ~ 100°C)

Parameter	Symbol	Conditions	MIN.	TYP.	MAX.	Unit
CLOCK pulse width	PW <sub>CLK</sub>	The period VI(CLK) is "H"	25	-	-	ns
		The period VI(CLK) is "L"	25	-	-	ns
Clock frequency	f <sub>CLK</sub>	Duty=50±10%	-	-	20	MHz
Set-up time for CLOCK terminal	t <sub>STUP</sub>	S-IN-CLK↑	10	-	-	ns
Hold time for CLOCK terminal	t <sub>HOLD</sub>	CLK↑ -S-IN	5	-	-	ns
CLK↑ -LATCH↓	t <sub>C-L</sub>	CLK↑ -LATCH↓	40	-	-	ns
LATCH↑ -CLK↑	t <sub>L-C</sub>	LATCH↑ -CLK↑	40	-	-	ns
LATCH↓ -EN↓	t <sub>L-EN</sub>	LATCH↓ -EN↓	40	-	-	ns
LATCH pulse width	PW <sub>LAT</sub>	The period LATCH is "L"	25	-	-	ns
Maximum CLK & LATCH rise time	t <sub>r</sub>	(Note 2)	-	-	500	ns
Maximum CLK & LATCH fall time	t <sub>f</sub>	(Note 2)	-	-	500	ns

Refer to the timing chart (p10)

Note 2:

If the device is connected in a cascade and t<sub>r</sub>/t<sub>f</sub> for the waveform is large, it might not be able to secure the timing required for data transfer.

Please consider the timing carefully.

## 1 0 – 3 . AC Electrical Characteristics

Parameter	Symbol	Conditions	MIN.	TYP.	MAX.	Unit
S-OUT propagation delay time	t <sub>PLH1</sub>	CLK↑ -S-OUT↑ CL= 10pF	5	20	50	ns
	t <sub>PHL1</sub>	CLK↑ -S-OUT↓ CL= 10pF	5	20	50	ns
OUT propagation delay time	t <sub>PLH2</sub>	XEN↓ -OUTn↑ ,R <sub>L</sub> = 30Ω R-EXT resistor= 5kΩ	-	100	400	ns
	t <sub>PHL2</sub>	XEN↑ -OUTn↓ ,R <sub>L</sub> = 30Ω R-EXT resistor = 5kΩ	-	100	400	ns
S-OUT rise time	t <sub>rS</sub>	CL= 10pF	-	-	30	ns
S-OUT fall time	t <sub>fS</sub>	CL= 10pF	-	-	30	ns
OUT rise time	t <sub>rD</sub>	R <sub>L</sub> = 30Ω	-	100	400	ns
OUT fall time	t <sub>fD</sub>	R <sub>L</sub> = 30Ω	-	100	400	ns
R-EXT settling time	t <sub>Iset</sub>	I <sub>OUT</sub> = 48.5±5mA R-EXT resistor = 5kΩ	-	-	10	μs

Please refer to the timing chart (p10)

1 1 . Timing Waveform

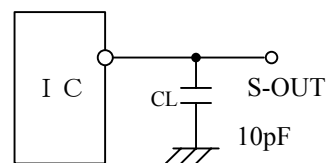
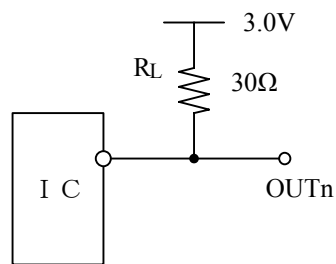
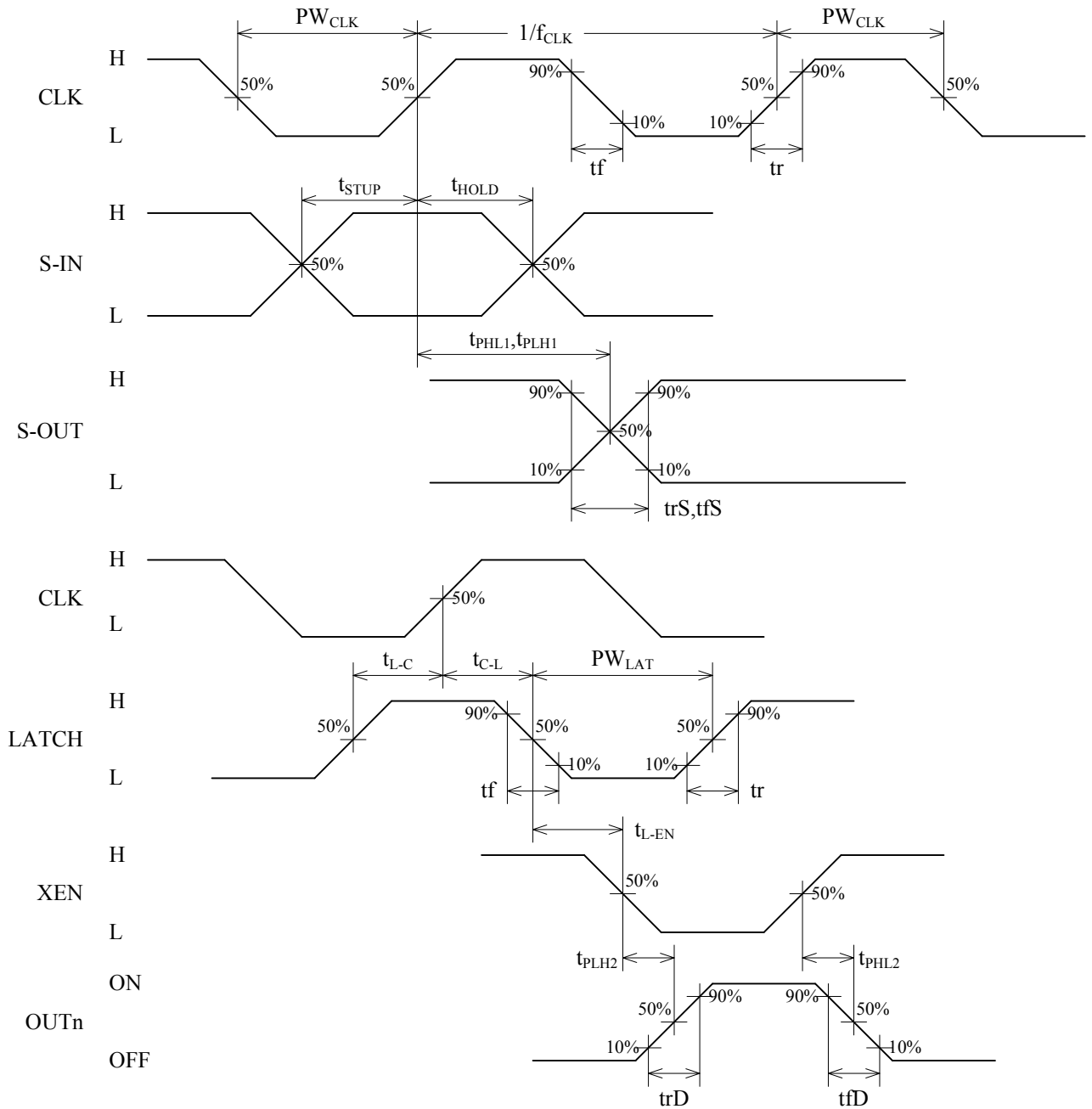

1 2 . Electrical characteristic curves

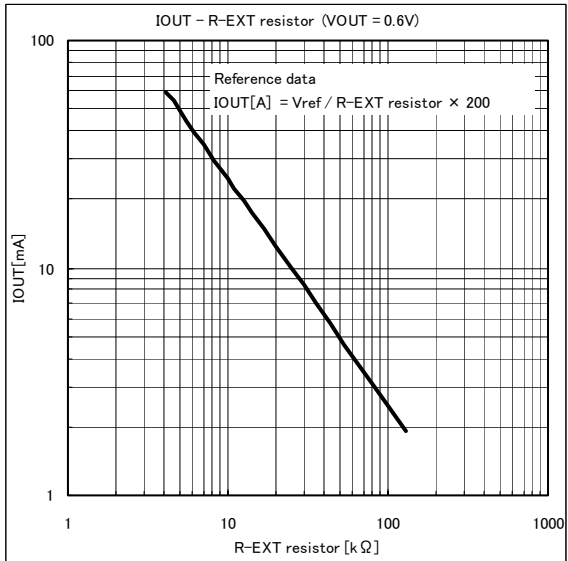
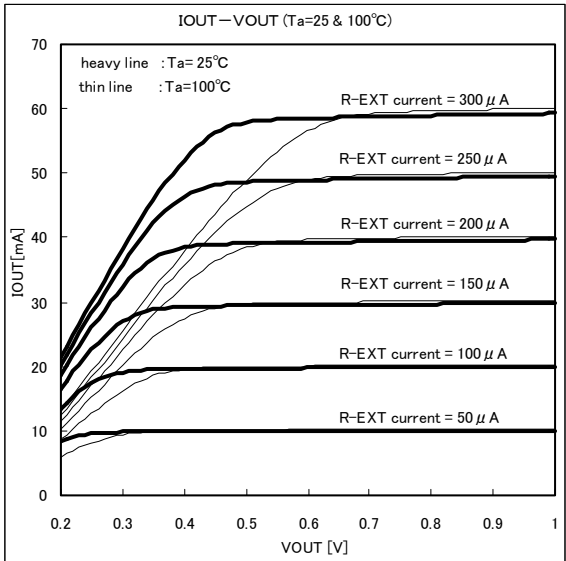
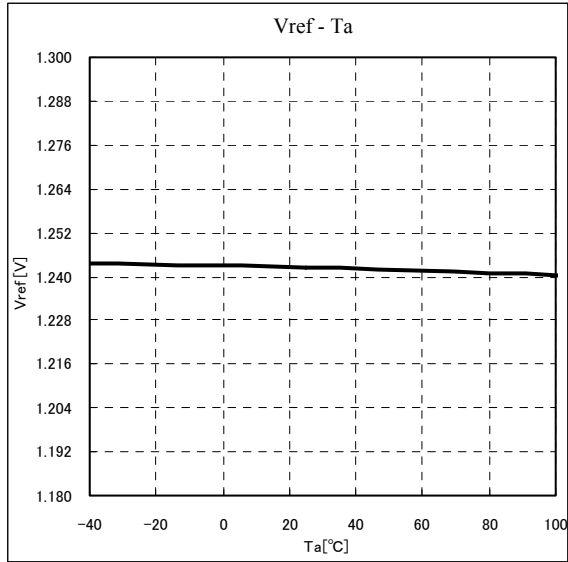
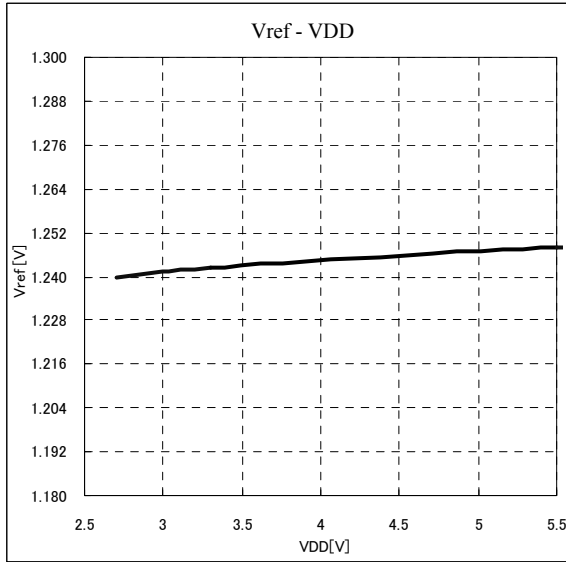
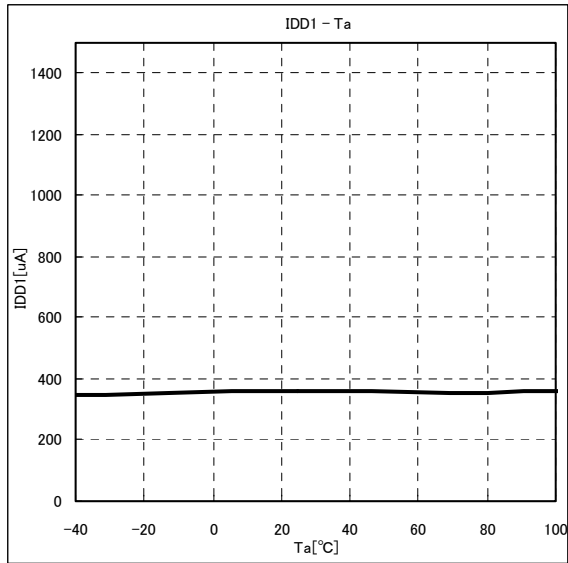
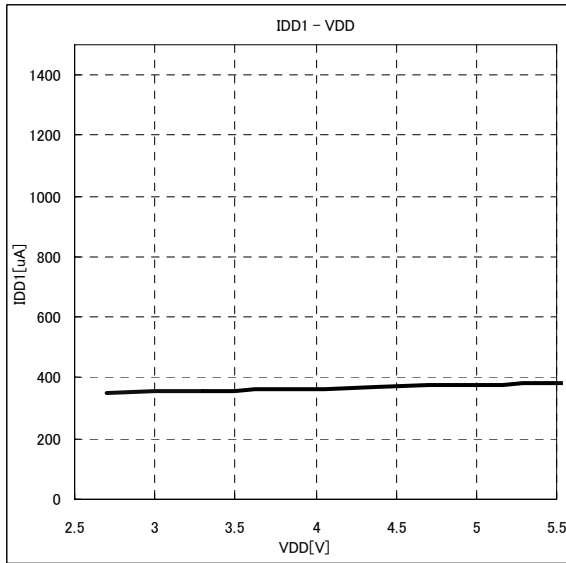

13. Application circuit example

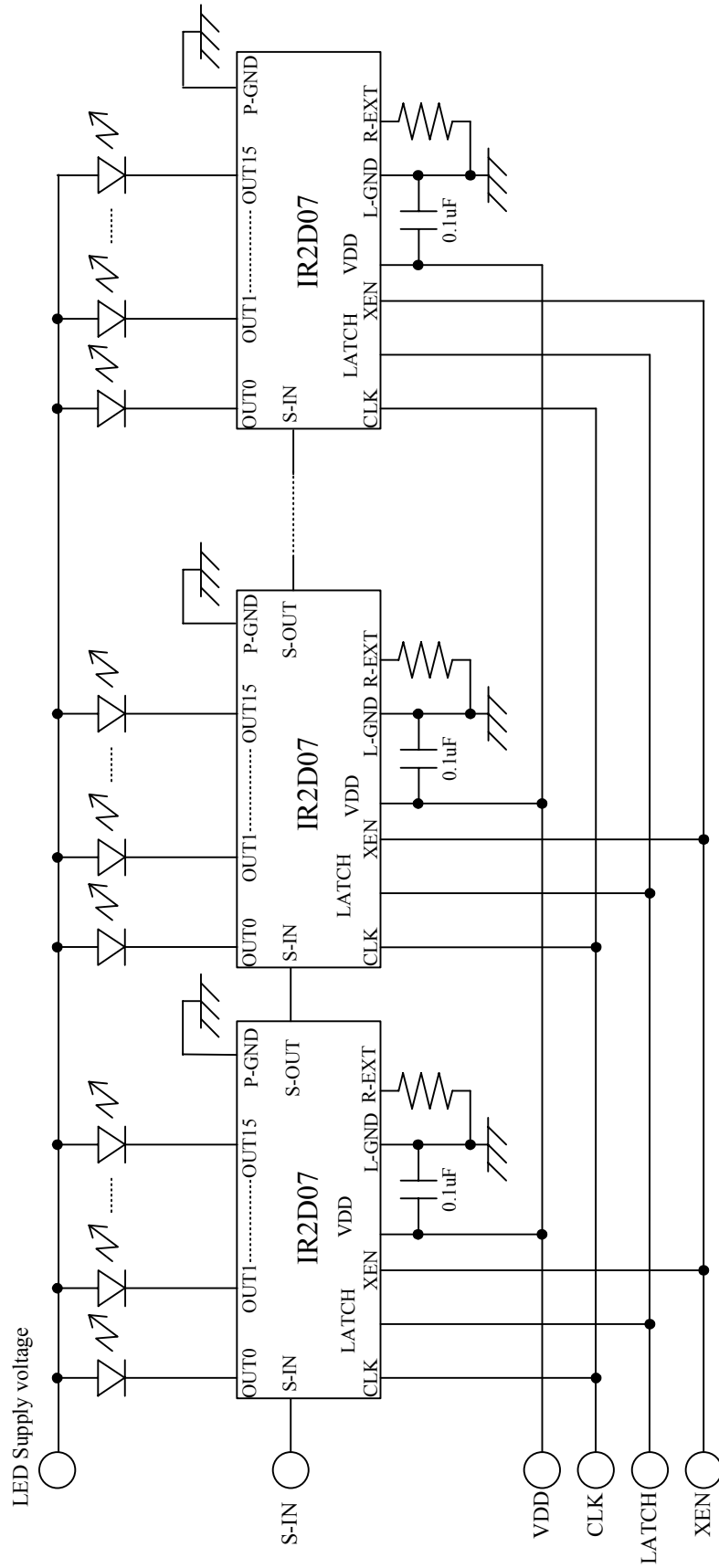

## 14 Package and packing specification

## [Applicability]

This specification applies to an IC package of the LEAD-FREE delivered as a standard specification.

## 1. Storage Conditions.

- Normal temperature : 5~35°C
- Normal humidity : 75% (Relative humidity) max.
- Storage period : One year max.
- \*"Humidity" means "Relative humidity"

## 2. Baking Condition.

Baking is no necessity.

## 3. Mounting conditions.

Please mount the ICs as follows in order to prevent the IC quality deteriorating.

## 3-1. Soldering conditions. (The following conditions apply only to one-time soldering.)

## (1) Solder dipping. (one-time dipping only)

- Temperature and period :
  - A) Peak temperature. 260°C max. for 10 seconds Max.
  - B) Preheat temperature of 120 to 150°C for 120±60 seconds
- Measuring point :
  - A) Solder bath.
  - B) IC package surface.
- Temperature profile :

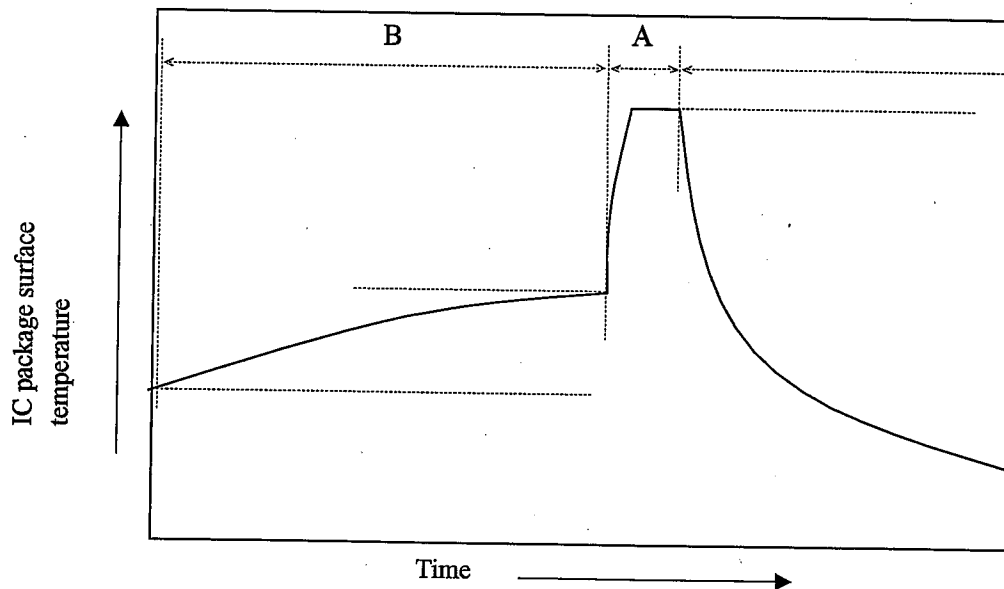

## (2) Manual soldering (soldering iron) (one-time soldering only)

Soldering iron should only touch the IC's outer leads.

- Temperature and period :
  - 380°C max. for 3 seconds Max. / pin max.
  - (Soldering iron should only touch the IC's outer leads.)
- Measuring point : Soldering iron tip.

## 4. Condition for removal of residual flux.

- (1) Ultrasonic washing power : 25 watts / liter max.
- (2) Washing time : Total 1 minute max.
- (3) Solvent temperature : 15~40°C

Reference
-----------

## 5. Package outline specification.

## 5-1. Package outline.

Refer to the attached drawing.

(Plastic body dimensions do not include burr of resin.)

## 5-2. LEAD FINISH or BALL TYPE

LEAD FREE TYPE (Sn-2%Bi) 10 $\mu$ m TYP.(Min. 5 $\mu$ m)

## 6. Markings.

## 6-1. Marking details. (The information on the package should be given as follows.)

- (1) Product name : IR2D07
- (2) Company name : SHARP
- (3) Date code : (Example) YYWW XXX
  - YY → Denotes the production year. (Last two digits of the year.)
  - WW → Denotes the production week. (01 · 02 · ~ · 52 · 53)
  - XXX → Denotes the production ref code.
- (4) "JAPAN" indicates the country of origin.

## 6-2. Marking layout.

The layout is shown in the attached drawing.

(However, this layout does not specify the size of the marking character and marking position.)



## Reference

(Note) It is those with an underline printing in a date code because of a LEAD FREE type.

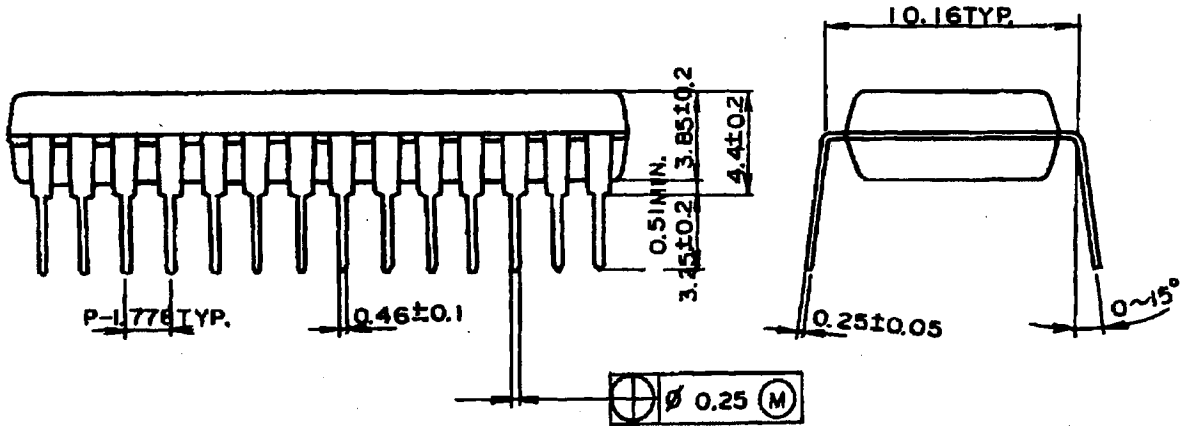
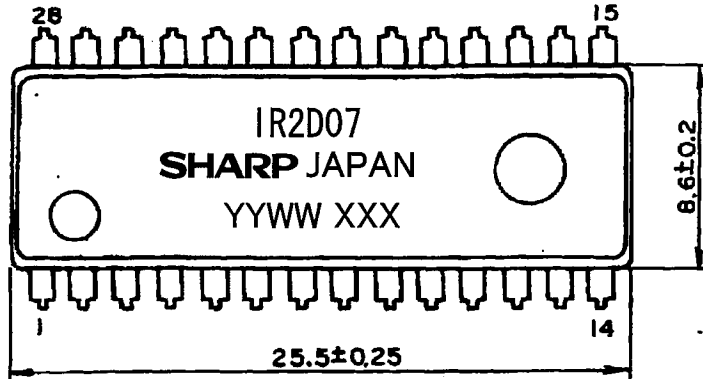

SDIP028-P-0400-AA858

LEAD TYPE	LEAD FINISH		LEAD MATERIAL
	Sn-2%Bi PLATING (10 $\mu$ m TYP.(Min. 5 $\mu$ m))		Cu
NAME	SDIP028-P-0400		NOTE : Plastic body dimensions do not include burr of resin.
DRAWING NO.	AA858	UNIT mm	

## Reference

## 7.Packing specifications.

## 7-1. Packing materials.

Material name	Material specifications	Purpose
Magazine	Anti-static treated plastic (20 devices/magazine)	Packing of devices.
Stopper	Plastic or rubber	Securing of devices.
Label	Paper (1piece/inner carton)	Indication of product name, quantity and packed date.
Inner carton	Cardboard (1000 devices/carton max.)	Packing the magazines.
Outer carton	Cardboard (4000 devices/carton max.)	Outer packing.

(Devices must be inserted into the magazine in the same direction.)

## 7-2.Outline dimension of magazine.

Refer to the attached drawing.

## 7-3. Outline dimension of carton.

Refer to the attached drawing.

## 8.Precautions for use.

- (1) Opening must be done on an anti-ESD treated workbench.  
All workers must also have undergone anti-ESD treatment.
- (2) The magazines have undergone either conductive or anti-ESD treatment.  
If another magazine is used , make sure it has also undergone conductive or anti-ESD treatment.
- (3) The devices should be mounted within one year of the date of delivery.

## Reference

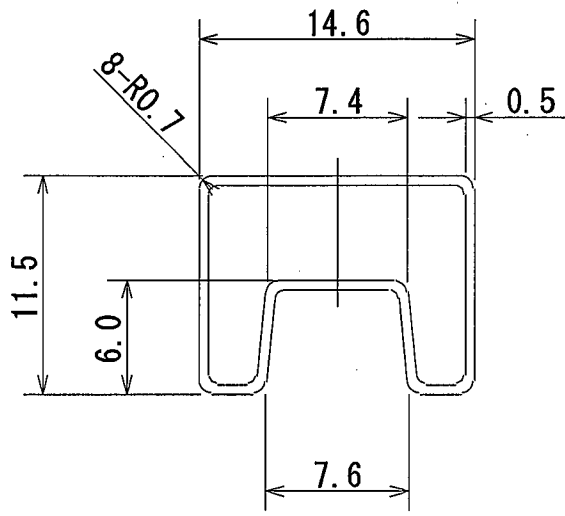
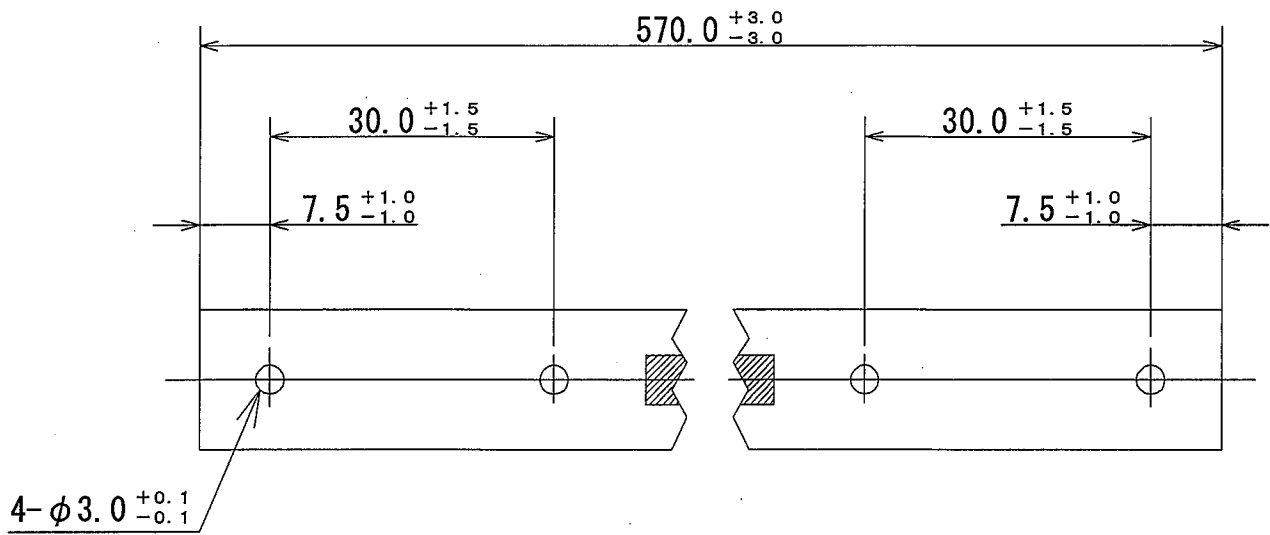

注記 : 片側ピンストッパー、片側ゴムストッパーとする。  
指示無き寸法公差は全て $\pm 0.5$ とする。

NOTES : One end of the magazine(sleeve) is plugged by a rubber stopper, and the other end is plugged by plastic pin-stopper.  
All tolerances are  $\pm 0.5$ mm unless otherwise specified.

名称 Name	DP400SPS-A2	備考 Note	
Drawing no.	CV1041	単位 Unit	mm

## Reference

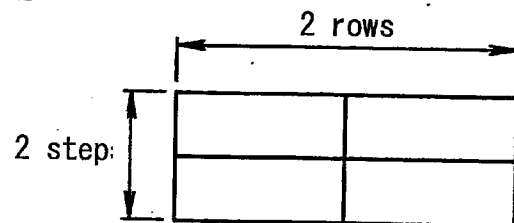
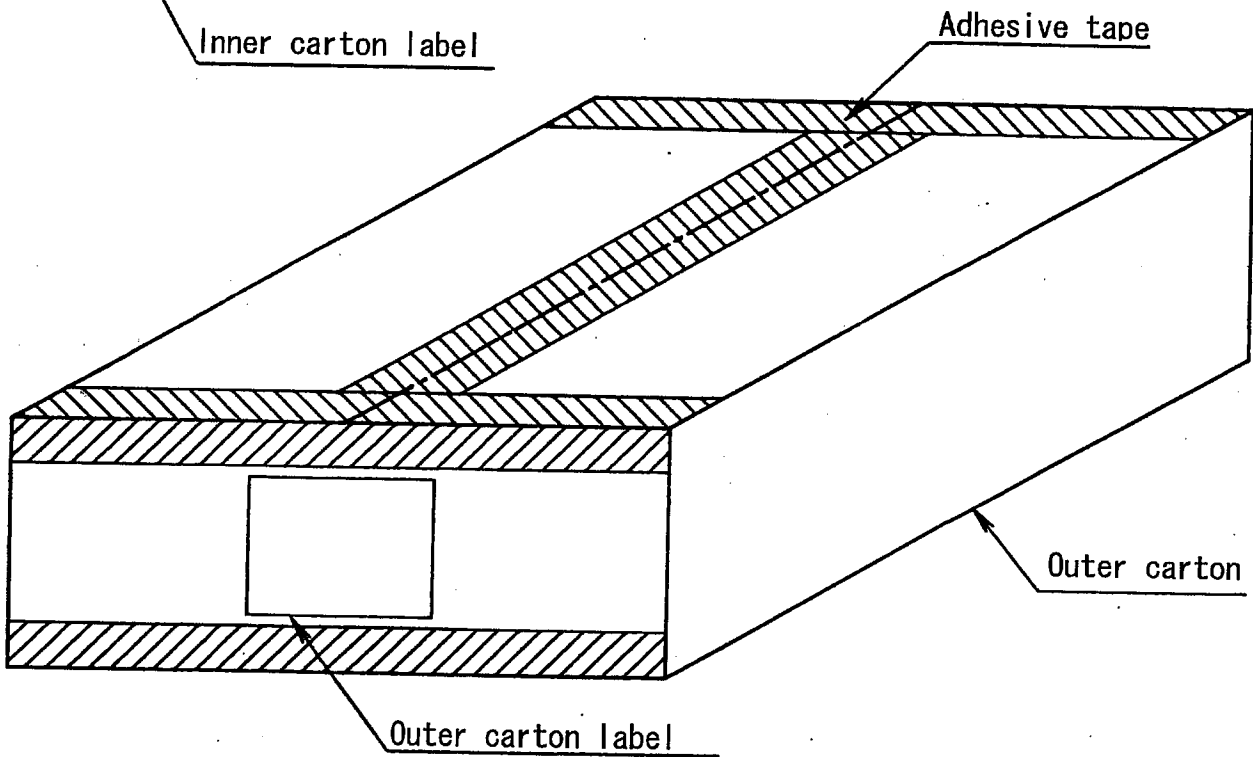
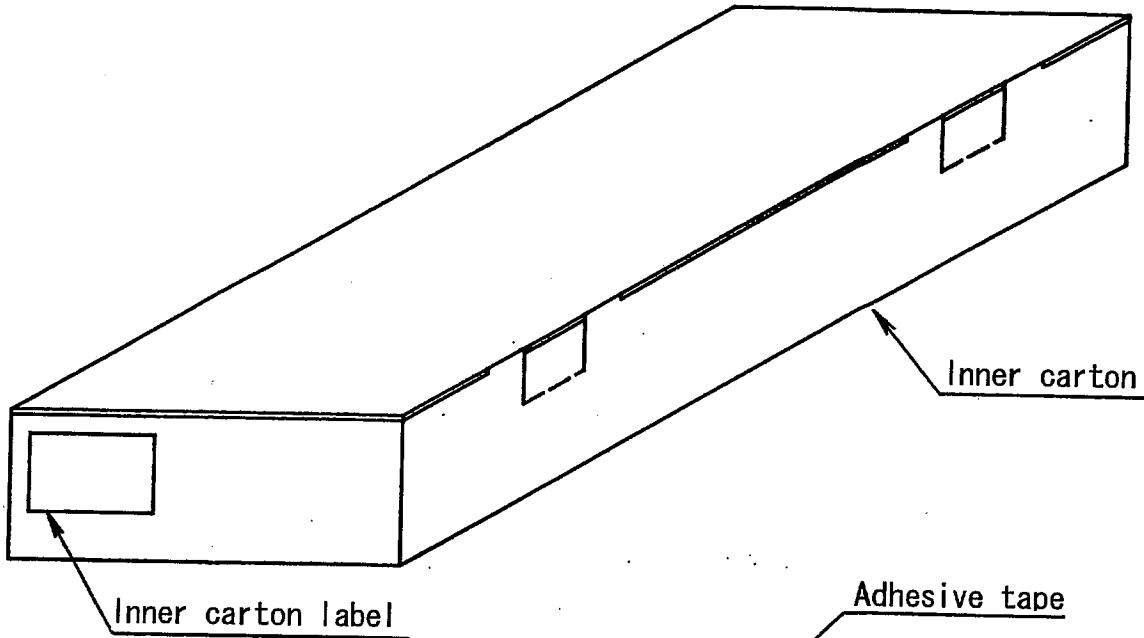

L × W × H  
 Inner carton - Outer dimensions : 590 × 150 × 70  
 Outer carton - Outer dimensions : 610 × 325 × 165

名称 NAME	Packing specifications	備考 NOTE	出荷数量が端数の場合、本仕様と異なることがあります。 There is a possibility different from this specification when the number of shipments is fractions.
DRAWING NO.	BJ381	単位 UNIT	mm

## Reference

(Note) The <<LEAD FREE>> display shows a lead free article.

"R.C." is Sharp's corporate logo indicating that the product is RoHS compliant.

### Inner carton label

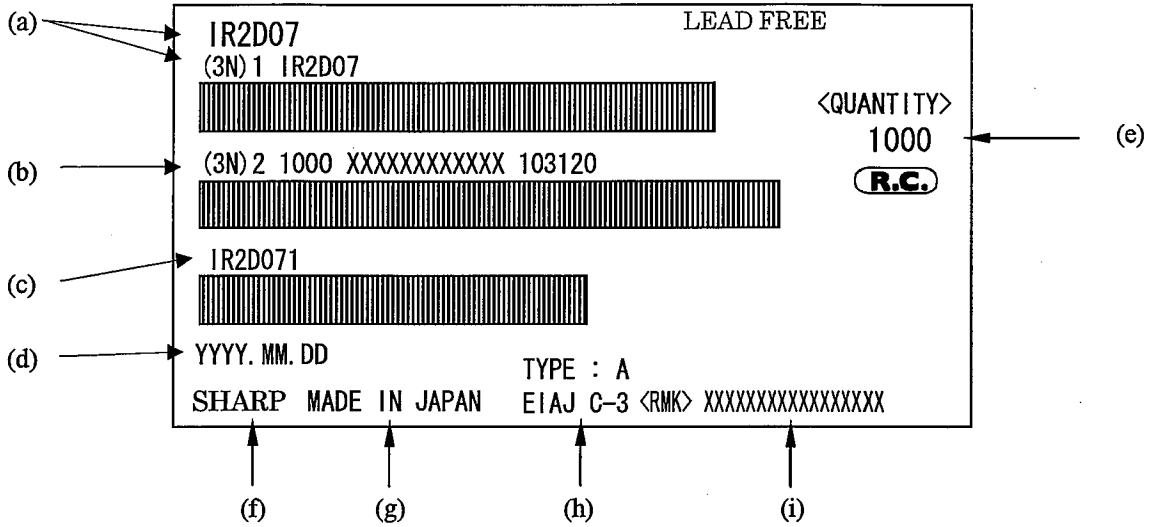

### Outer carton label

(Former) EIAJ B Standard conforming

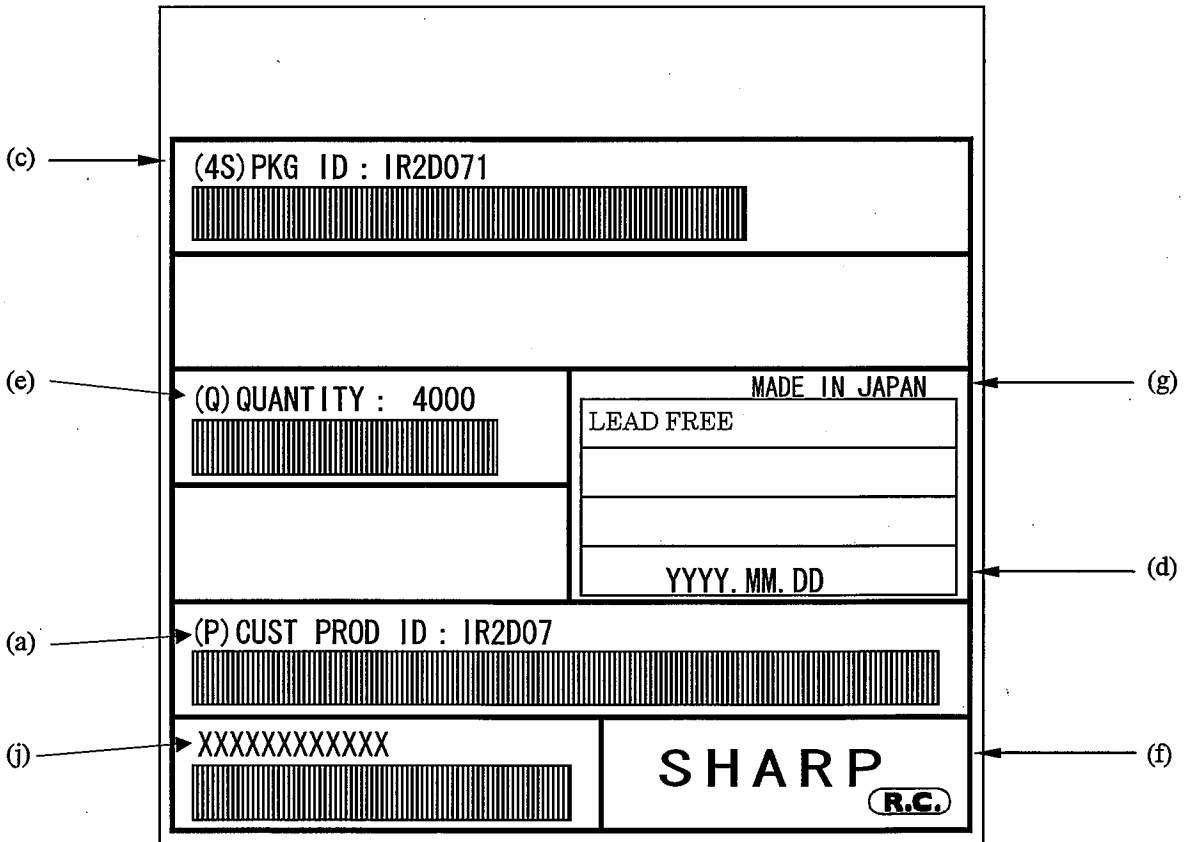

- (a) Product name
- (b) Quantity PD lot Company code
- (c) Part No. (SHARP)
- (d) Packed date
- (e) Quantity
- (f) "SHARP" Logo
- (g) The country of origin
- (h) Type name (Conformity standard)
- (i) Assembly management No.
- (j) Shipment lot