



# PRODUCT SPECIFICATION

DOCUMENT NO. ENS000108250

DESCRIPTION	DRAWN BY	DESIGNED BY	CHECKED BY	APPROVED BY
MOVS4032DG Series	Sandy	Hung Tsai	C.P. Huang	Shawn Yeh

## MOVS4032DG Series Engineering Specification

### 1. Scope

- (1). SMD type Metal Oxide Varistor
- (2). High transient current capability
- (3). Encapsulation material according to UL94-V0
- (4). RoHS compliant
- (5). UL/cUL 1449 approved

### Applications

- (1). Power supply
- (2). Home appliance
- (3). Industrial equipment
- (4). Telecommunication or telephone system

### 2. Explanation of Part Number

<u>MOV</u>	<u>S</u>	<u>4032</u>	<u>431</u>	<u>DG</u>
(1)	(2)	(3)	(4)	(5)

- (1). Metal oxide varistor
- (2). Type: S=single; A=array
- (3). Size
- (4). Varistor voltage
- (5). Inpaq Control code

### 3. Construction & Dimension

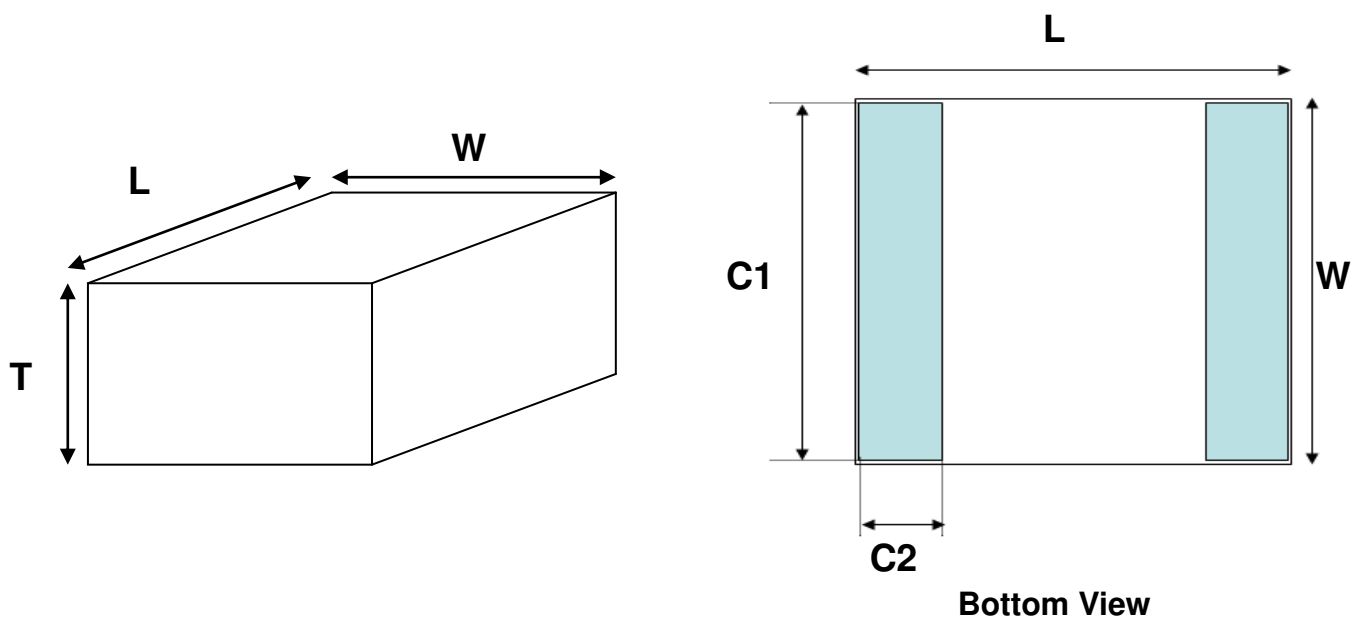

Unit : mm	4032	Note
L	$10.1 \pm 0.2$	
W	$8.2 \pm 0.2$	
T	$3.2 \pm 0.3$	reference table 4.1
	$4.2 \pm 0.3$	
	$5.6 \pm 0.3$	
C1	$7.4 \pm 0.3$	
C2	$1.6 \pm 0.3$	

#### 4. Part ratings and characteristics:

##### 4.1. Rating

	Working voltage		Varistor voltage	Leakage Current	Clamping Voltage	Peak current	Component thickness
Symbol	$V_{RMS}$	$V_{DC}$	$V_V$	IL	$V_C$	$i_{max}$	T
Units	Volts	Volts	Volts	uA	Volts	Amps	mm
	(Max.)	(Max.)		(Max.)	(Max.)	(Max.)	
Test Condition			1mA DC	$V_V \cdot 80\%$ (at initial state)	8/20 $\mu$ s	8/20 $\mu$ s	
MOVS4032180DG	11	14	16.2~19.8	50	40(2.5A)	250	3.2
MOVS4032220DG	14	18	19.8~24.2	50	48(2.5A)	250	3.2
MOVS4032270DG	17	22	24.3~29.7	50	60(2.5A)	250	3.2
MOVS4032330DG	20	26	29.7~36.3	50	73(2.5A)	250	4.2
MOVS4032390DG	25	31	35.1~42.9	50	80(2.5A)	250	4.2
MOVS4032470DG	30	38	42.3~51.7	50	104(2.5A)	250	4.2
MOVS4032560DG	35	45	50.4~61.6	50	123(2.5A)	250	4.2
MOVS4032680DG	40	56	61.2~74.8	50	145(2.5A)	250	4.2
MOVS4032820DG	50	66	73.8~90.2	50	135(10A)	1200	3.2
MOVS4032101DG	60	85	90~110	50	165(10A)	1200	3.2
MOVS4032121DG	75	102	108~132	50	200(10A)	1200	4.2
MOVS4032151DG	95	127	135~165	50	250(10A)	1200	4.2
MOVS4032181DG	120	160	170~207	50	300(10A)	1200	4.2
MOVS4032201DG	130	175	185~225	50	340(10A)	1200	4.2
MOVS4032221DG	140	180	198~242	50	360(10A)	1200	4.2
MOVS4032241DG	150	200	216~264	50	395(10A)	1200	4.2
MOVS4032271DG	180	230	255~311	50	455(10A)	1200	4.2
MOVS4032301DG	195	250	270~330	50	500(10A)	1200	4.2
MOVS4032331DG	210	275	297~363	50	550(10A)	1200	4.2
MOVS4032361DG	230	300	324~396	50	595(10A)	1200	4.2
MOVS4032391DG	250	330	351~429	50	650(10A)	1200	4.2
MOVS4032431DG	275	370	387~473	50	710(10A)	1200	5.6
MOVS4032471DG	300	385	423~517	50	775(10A)	1200	5.6
MOVS4032511DG	320	420	459~561	50	845(10A)	1200	5.6
MOVS4032561DG	360	470	522~638	50	925(10A)	1200	5.6

Symbol	Working voltage		Varistor voltage	Leakage Current	Clamping Voltage	Peak current	Component thickness
	$V_{RMS}$	$V_{DC}$	$V_V$	IL	$V_C$	$i_{max}$	T
Units	Volts	Volts	Volts	uA	Volts	Amps	mm
	(Max.)	(Max.)		(Max.)	(Max.)	(Max.)	
Test Condition			1mA DC	$V_V \cdot 80\%$ (at initial state)	8/20 $\mu$ s	8/20 $\mu$ s	
MOVS4032621DG	390	505	558~682	50	1025(10A)	1200	5.6
MOVS4032681DG	420	560	612~748	50	1120(10A)	1200	5.6
MOVS4032751DG	460	615	675~825	50	1240(10A)	1200	5.6
MOVS4032781DG	485	640	702~858	50	1290(10A)	1200	5.6
MOVS4032821DG	510	670	738~902	50	1355(10A)	1200	5.6

$V_{DC}$  –Maximum DC operating voltage the varistor can maintain

$V_V$  – Voltage across the device measured at 1mA DC current.

Equivalent to  $V_b$ , “Breakdown Voltage”.

$V_C$  – Maximum peak voltage across the varistor measured at 8/20us waveform.

$i_{max}$  – Maximum peak current which may be applied with 8/20us waveform without device failure

## 5. General electrical specifications

### 5.1. General technical data (OTHER SPEC)

Operating temperature	-40 ... +85°C
Storage temperature (on board)	-40 ... +85°C
Solderability	245±5°C, 3 ±1 sec
Solder leach resistance	260±5°C, 10 ±1 sec

### 5.2. Taping Package Storage Condition

Storage Temperature: 5 to 40°C

Relative Humidity: to 65%

Storage Time: 12 months max

## 6. Taping Package and Label Marking

### 6.1. Carrier tape dimensions

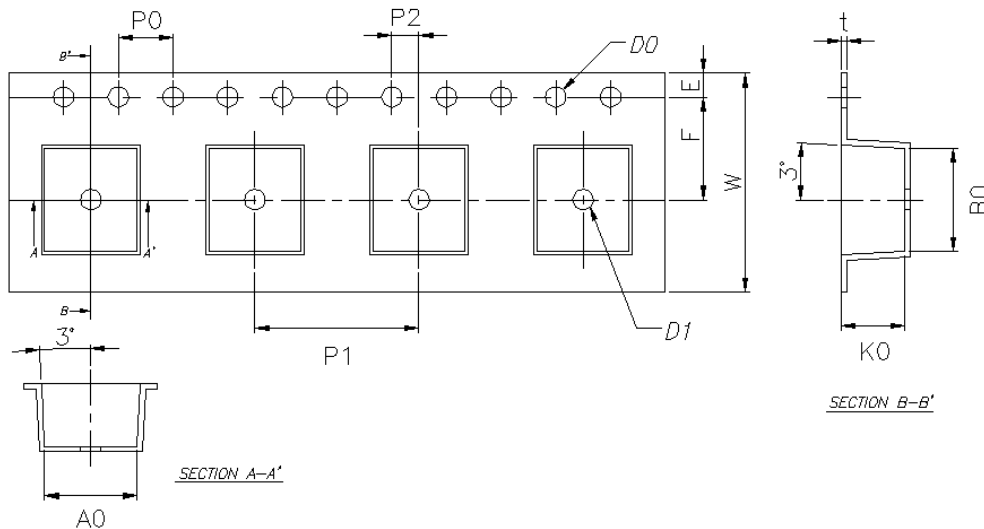

Type	W	E	F	D0	D1	P0	P0 x10
4032	16.00 ±0.30	1.75 ±0.10	7.50 ±0.15	1.50 +0.10/-0.00	1.50 +0.10/-0.00	4.00 ±0.10	40.00 ±0.20
	t	A0	B0	K0		P1	P2
	0.50 ±0.05	8.55 +0.15/-0.05	10.45 +0.15/-0.05	6.20(max)		12.00 ±0.10	2.00 ±0.15

## 6.2. Taping reel dimensions

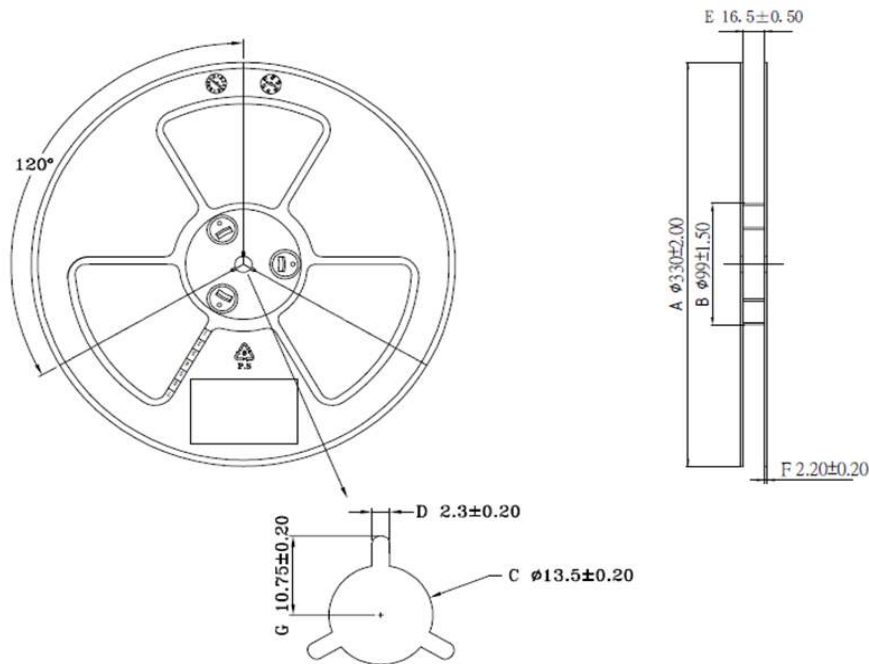

單位：(mm)

Type	A	B	C	D	E	F	G
13"	330 ±2.00	99 ±1.50	13.50 ±0.20	2.30 ±0.20	16.50 ±0.50	2.20 ±0.20	10.75 ±0.20

## 6.3. Taping specifications

There shall be the portion having no product in both the head and the end of taping, and there shall be the cover tape in the head of taping.

## 6.4. Label Marking

The label specified as follows shall be put on the side of reel.

- (1) Part No.
- (2) Quantity
- (3) Lot No.

Part No. And Quantity shall be marked on outer packaging.

## 6.5. Quantity of products in the taping package

- (1) Standard quantity: 900pcs/Reel for MOVS4032 T=5.6mm , 1100pcs/Reel for MOVS4032 T=4.2mm , 1400pcs/Reel for MOVS4032 T=3.2mm .
- (2) Shipping quantity is a multiple of standard quantity.

## 7. Precautions for Handling

### 7.1. Solder cream in reflow soldering

Refer to the recommendable land pattern as printing mask pattern for solder cream.

(1) Print solder in a thickness of 0.1mm

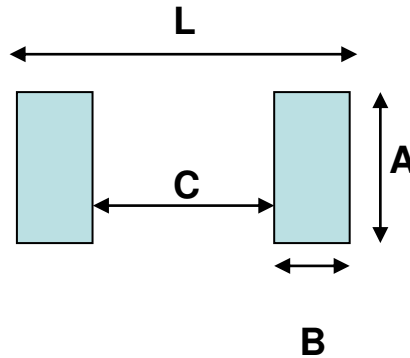

Unit: mm

Item		A	B	C	L
Size(EIA)	4032	8.6	2.2	6.2	10.5

### 7.2. Precaution for handling of substrate

Do not exceed to bend the board after soldering this product extremely.

(Reference examples)

- Mounting place must be as far as possible from the position, which is close to the break line of board, or on the line of large holes of board.
- Do not bend extremely the board, in mounting another component.  
If necessary, use back-up pin (support pin) to prevent from bending extremely.
- Do not break the board by hand. We recommend to using the machine or the jig to break it.

### 7.3. Precaution for soldering

Note that rapid heating, rapid cooling or local heating will easily damage this product.

Do not give heat shock over 100°C in the process of soldering. We recommend taking preheating and gradual cooling.



#### 7.4. Recommendable reflow soldering

Profile Feature	Pb-Free Assembly
Average Ramp-Up Rate (T <sub>smax</sub> to T <sub>p</sub> )	3° C/second max.
<b>Preheat</b> – Temperature Min (T <sub>smin</sub> ) – Temperature Max (T <sub>smax</sub> ) – Time (t <sub>smin</sub> to t <sub>smax</sub> )	150 °C 200 °C 60-180 seconds
Time maintained above: – Temperature (T <sub>L</sub> ) – Time (t <sub>L</sub> )	217 °C 60-150 seconds
Peak/Classification Temperature (T <sub>p</sub> )	250 °C
Time within 5 °C of actual Peak Temperature (t <sub>p</sub> )	20-40 seconds
Ramp-Down Rate	6 °C/second max.
Time 25 °C to Peak Temperature	8 minutes max.

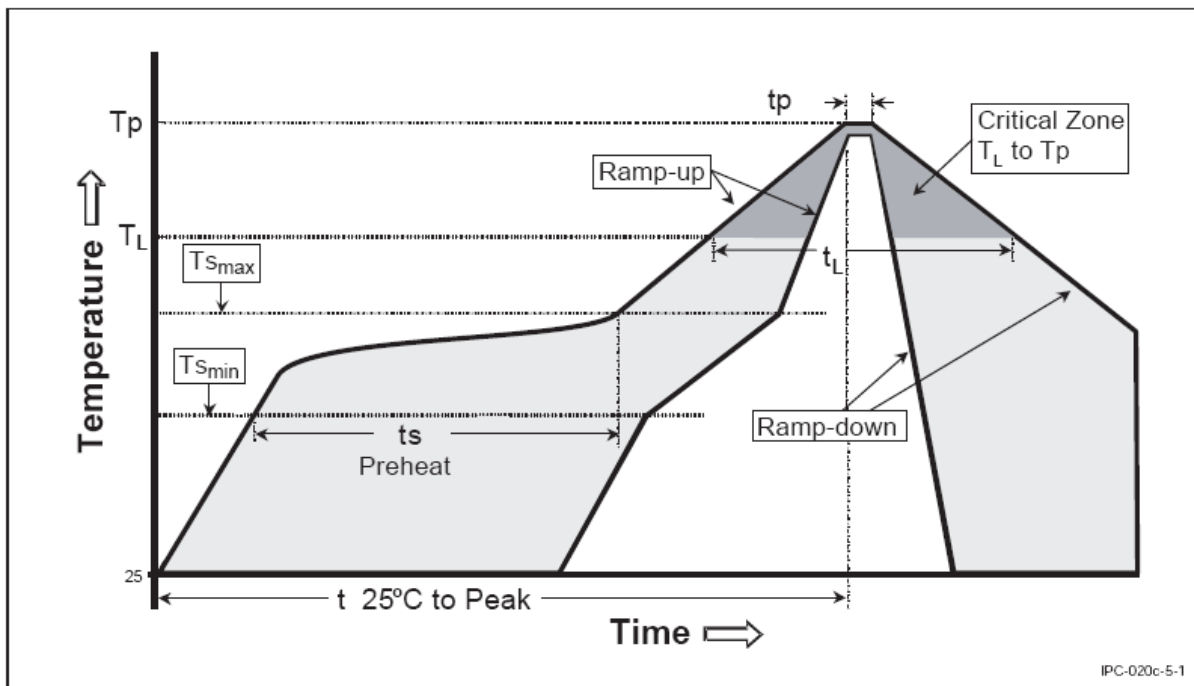

\*According to J-STD-020C

### 7.5. Soldering gun procedure

Note the follows, in case of using solder gun for replacement.

- (1) The tip temperature must be less than 280°C for the period within 3 seconds by using soldering gun under 30 W.
- (2) The soldering gun tip shall not touch this product directly.

### 7.6. Soldering volume

Note that excess of soldering volume will easily get crack the body of this product.