

This drawing involves proprietary design rights of Tyco Electronics Corporation, and all design, manufacture, reproduction, use and sale rights regarding the same are expressly reserved. It is submitted for a specific purpose and the recipient by accepting this drawing, assumes custody and control and agrees to take reasonable precautions; (a) that this drawing will not be copied and reproduced, in whole or in part, or its contents revealed in any manner, or to any person except to meet the purpose for which it was delivered and (b) that any special features peculiar to this design will not be incorporated in other projects without the expressed written permission of Tyco Electronics Corporation.

REVISIONS			
EC	REV	DESCRIPTION	DATE
CPR	A	NEW RELEASE	08/31/05

NOTES: UNLESS OTHERWISE SPECIFIED.

1. PART NUMBER CHANGES AND OR DESIGN CHANGES AFFECTING ITEM INTERCHANGEABILITY REQUIRE PRIOR ELCON APPROVAL AND AUTHORIZATION BY REVISION TO THIS DRAWING.

2. MATERIALS:

INSULATORS: THERMOPLASTIC, GLASS REINFORCED, COLOR BLACK. UL94V-0 FLAMMABILITY RATED.

COMPLIANT SIGNAL PIN: PHOSPHOR BRONZE ALLOY.

POWER CONTACTS: PHOSPHOR BRONZE ALLOY, COPPER ALLOY.

CROWN BANDS: BERYLLIUM COPPER ALLOY.

GUIDE PIN: BRASS COPPER ALLOY.

3. FINISHES:

CONTACTS: GOLD PLATED PER MIL-G-45204 TYPE II, CLASS 0, .000030" MIN. THK, OVER NICKEL PER QQ-N-290, CLASS 2, .000040" MIN. THICKNESS.

TERMINALS: TIN PLATED, MATTE FINISH 000040" MIN. THICKNESS.

GUIDE PIN: NICKEL PLATED PER AMS 2404.

4. MOUNTING FLANGES ACCEPT M3 OR #4 SCREWS, (USER SUPPLIED).

5. ITEMS PROVIDED TO THIS SPECIFICATION TO BE PERMANENTLY IDENTIFIED PER THE FOLLOWING IDENTIFIER:

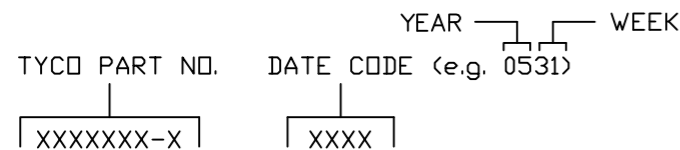

6. MODULE INFORMATION

CONNECTOR	TYCO PART NUMBER	CATALOG MODULE #	QTY	SIZE NO.	CONTACT QTY	MATING PIN	MAX. CURRENT (PER CONTACT)	CONTACT SPACING	VOLTAGE RATING*	
PIN	6646326-1	FP0201	3	8	3	1.25 X 7.00 [.049 X .276]	35 AMPERES	7.50 [L2953]	250 VOLTS	
		FP0202	3		3					
		FP0400	1	22	24	.64 [L025] SQ.	3 AMPERES	2.50 [L0984]	125 VOLTS	
		FP0503	2	STRAIGHT GUIDE PIN						
		FP0500	1	LEFT MOUNTING FLANGE						
		FP0501	1	RIGHT MOUNTING FLANGE						

\*IAW IEC-950

<p>THIRD ANGLE PROJECTION</p> <p>UNLESS OTHERWISE SPECIFIED DIMENSIONS ARE IN METRIC [INCHES]</p> <p>TOLERANCES</p> <p>ANGLES ± .5°</p> <p>DECIMALS</p> <p>.XX ± .25 [.010]</p> <p>.X ± .5 [.020]</p>	<p>MM OR MM [INCH]</p> <p>INCH</p>	<p>DRAWN</p> <p>R. F. A.</p>	<p>DATE</p> <p>08/31/05</p>	<p><b>tyco</b> Tyco Electronics Corporation <b>Electronics</b> Menlo Park, Ca 94025</p> <p><b>ELCON</b></p>
	<p>CHECKED</p>	<p>APPROVED</p>	<p>APPROVED</p>	<p>TITLE</p> <p>CONNECTOR, PIN, STRAIGHT COMPLIANT TAILS FLATPAQ</p>
	<p>D. CHAU</p>	<p>DCA APPROVED</p>	<p>M. ALIM</p>	<p>SIZE DWG NUMBER</p> <p>B C = 6646326</p>
	<p>ACAD FILE NUMBER</p> <p>C6646326A.DWG</p>	<p>DWG SCALE</p> <p>1 = 1</p>	<p>REV.</p> <p>A</p>	<p>SH 1 OF 3</p>

This drawing involves proprietary design rights of Tyco Electronics Corporation, and all design, manufacture, reproduction, use and sale rights regarding the same are expressly reserved. It is submitted for a specific purpose and the recipient by accepting this drawing, assumes custody and control and agrees to take reasonable precautions; (a) that this drawing will not be copied and reproduced, in whole or in part, or its contents revealed in any manner, or to any person except to meet the purpose for which it was delivered and (b) that any special features peculiar to this design will not be incorporated in other projects without the expressed written permission of Tyco Electronics Corporation.

REVISIONS			
EC	REV	DESCRIPTION	DATE
		SEE SHEET 1	

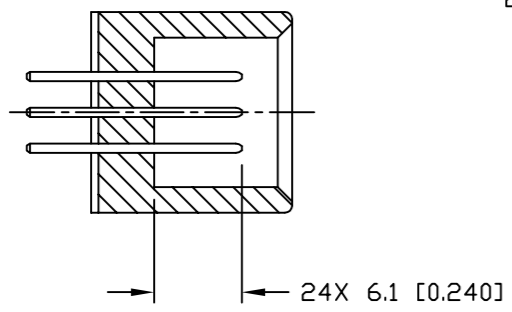
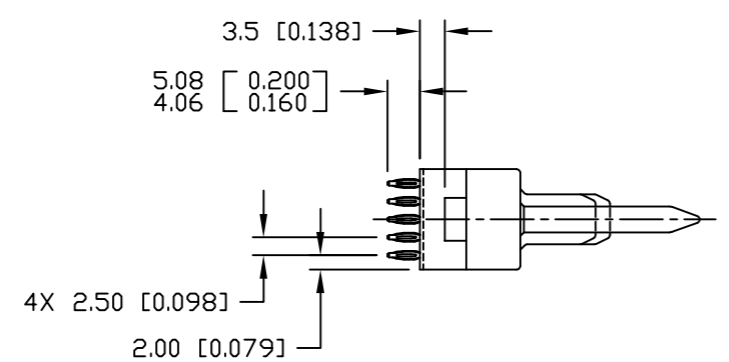

SECTION A-A

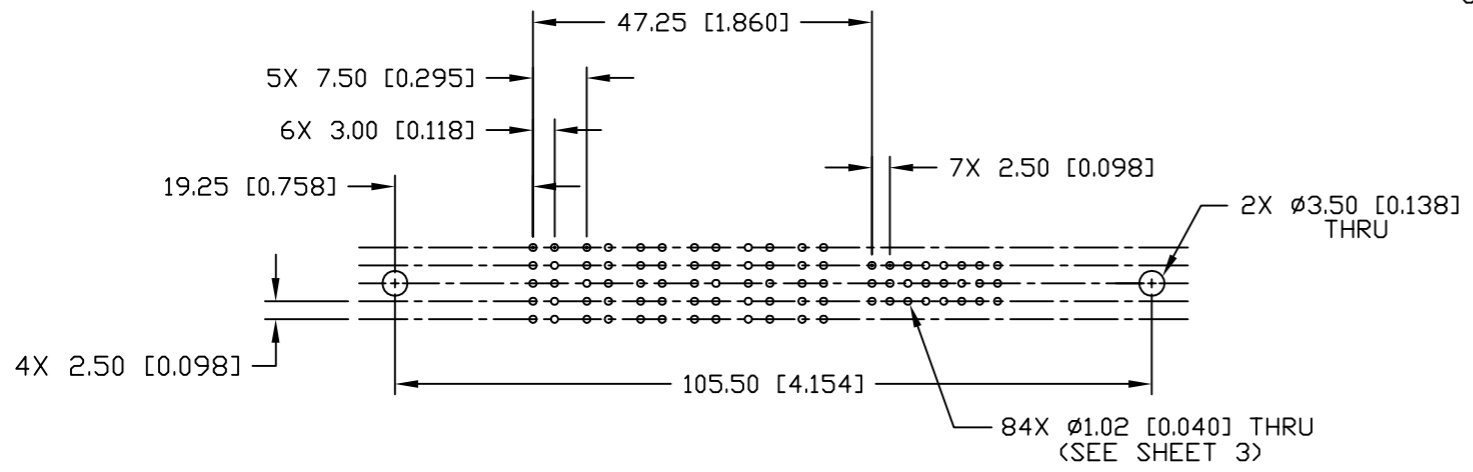
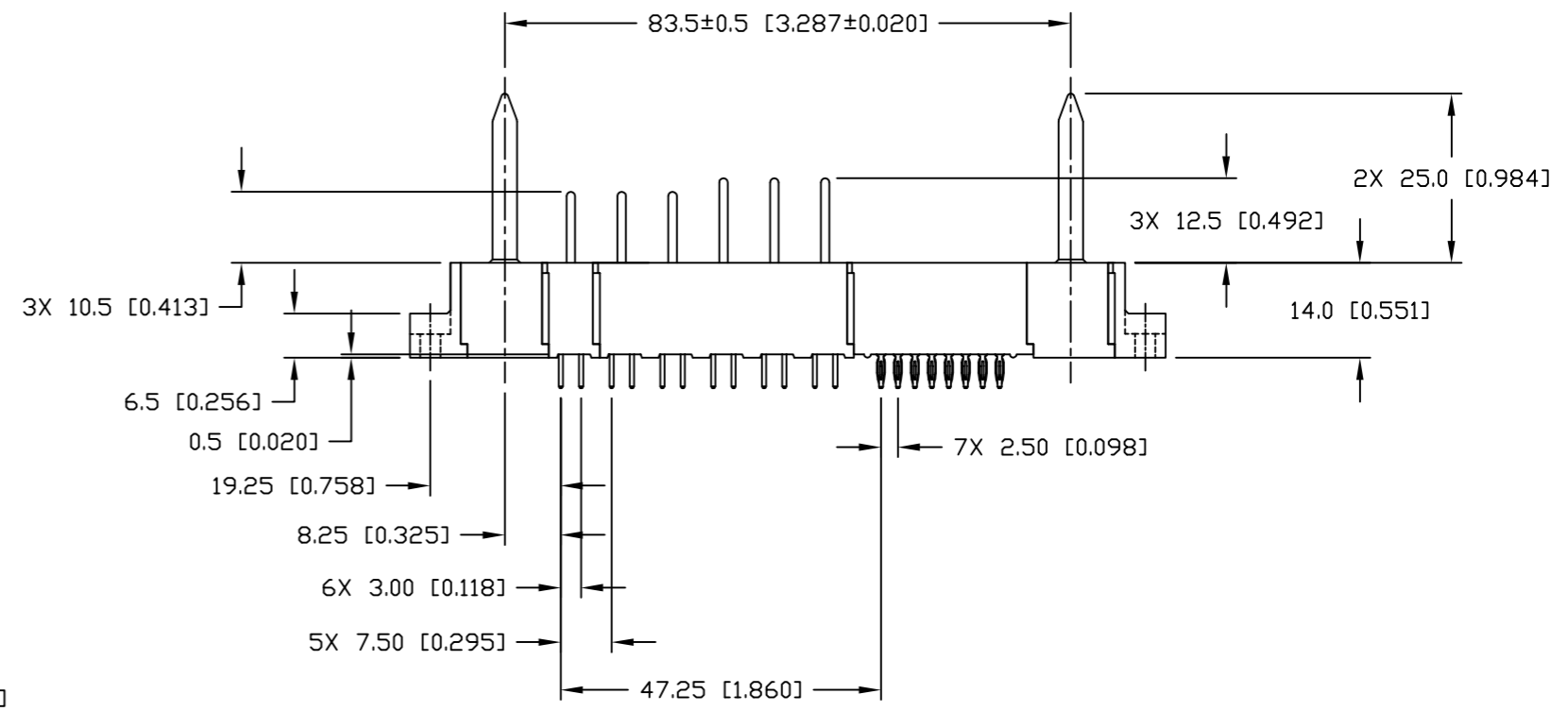
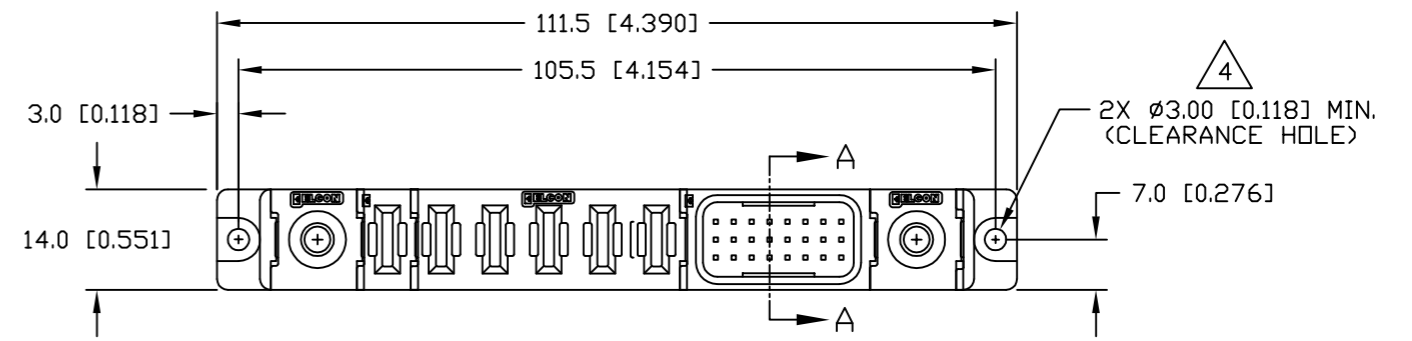

PRINTED CIRCUIT LAYOUT

← MM OR MM [INCH]  THIRD ANGLE PROJECTION UNLESS OTHERWISE SPECIFIED DIMENSIONS ARE IN METRIC [INCHES] TOLERANCES ANGLES ± .5° DECIMALS .XX ± .25 [.010] .X ± .5 [.020]	DRAWN R. F. A.	DATE 08/31/05	 Tyco Electronics Corporation Menlo Park, Ca 94025 	TITLE CONNECTOR, PIN, STRAIGHT COMPLIANT TAILS FLATPAQ			
	CHECKED	APPROVED				APPROVED	D. CHAU
	APPROVED	DCA APPROVED	M. ALIM	DATE 09/13/05	SIZE B	DWG NUMBER C = 6646326	REV. A
	ACAD FILE NUMBER C6646326A.DWG	DWG SCALE 1 = 1	SH 2 OF 3				

This drawing involves proprietary design rights of Tyco Electronics Corporation, and all design, manufacture, reproduction, use and sale rights regarding the same are expressly reserved. It is submitted for a specific purpose and the recipient by accepting this drawing, assumes custody and control and agrees to take reasonable precautions; (a) that this drawing will not be copied and reproduced, in whole or in part, or its contents revealed in any manner, or to any person except to meet the purpose for which it was delivered and (b) that any special features peculiar to this design will not be incorporated in other projects without the expressed written permission of Tyco Electronics Corporation.

REVISIONS

EC	REV	DESCRIPTION	DATE
		SEE SHEET 1	

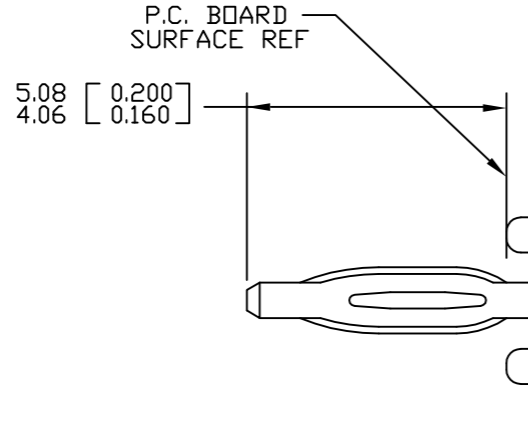

COMPLIANT PIN DETAIL

INSERTION/EXTRACTION FORCES  
 MAXIMUM PUSH-IN: 133.3N PER PIN [30 LBS]  
 MINIMUM PUSH-OUT: 44.4N PER PIN [10 LBS]

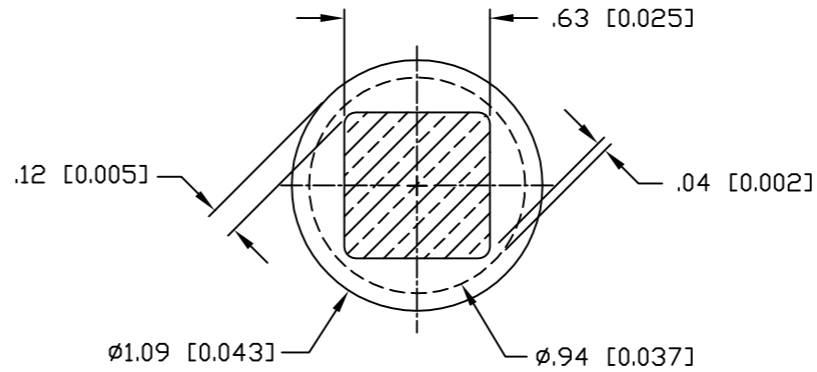

SOLDER TERMINATION AREA

RECOMMENDED PRINTED CIRCUIT HOLE  
 FINISHED HOLE:  $\phi 1.02 [0.040] \pm .08 [0.003]$   
 DRILLED HOLE:  $\phi 1.15 [0.0453] \pm .013 [0.0005]$   
 COPPER PLATE: .025 [0.0010] MINIMUM (PER SURFACE)  
 TIN PLATE: .008 [0.0003] MINIMUM (PER SURFACE)

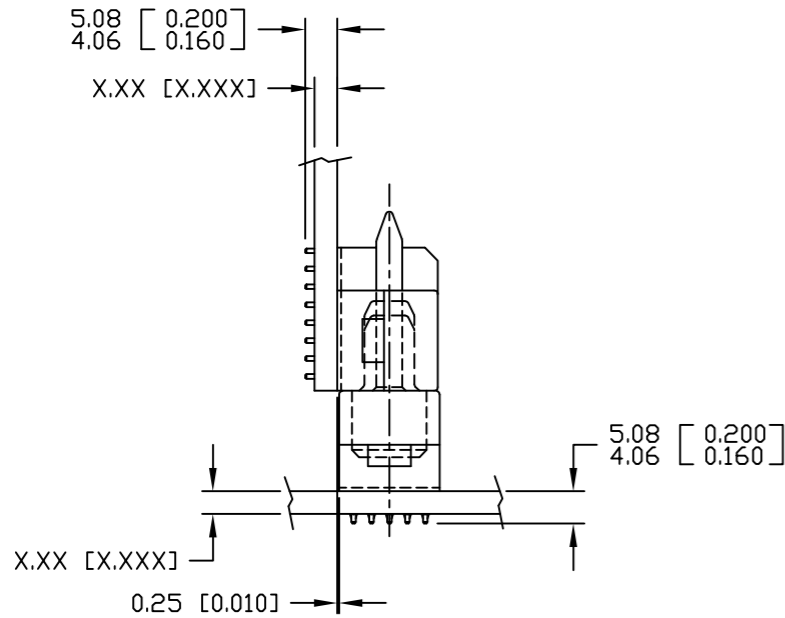

MATED CONDITION

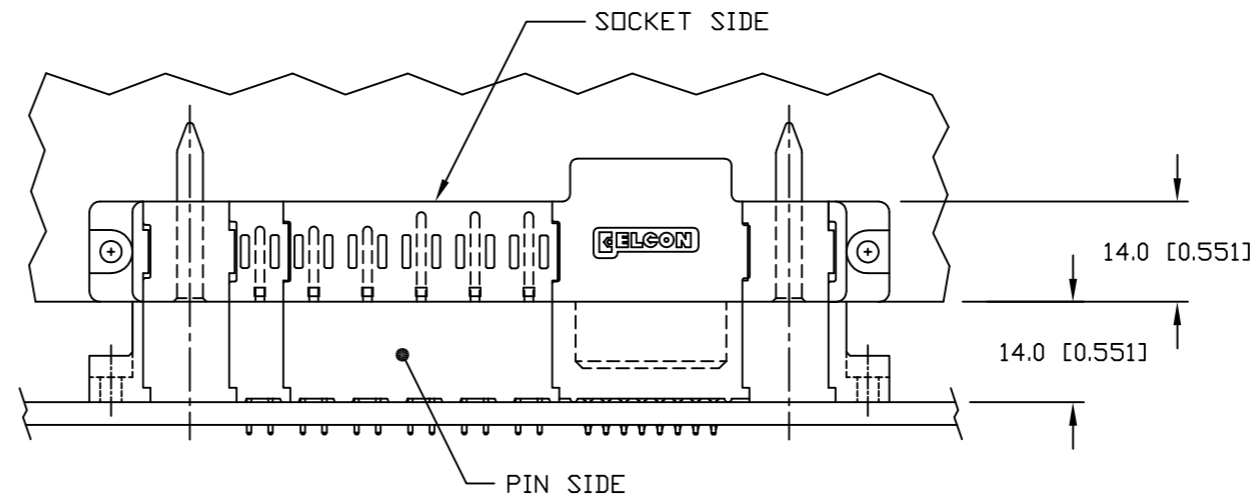

MM INCH  THIRD ANGLE PROJECTION UNLESS OTHERWISE SPECIFIED DIMENSIONS ARE IN METRIC [INCHES] TOLERANCES ANGLES $\pm .5^\circ$ DECIMALS .XX $\pm .25 [0.010]$ .X $\pm .5 [0.020]$	DRAWN R. F. A. CHECKED APPROVED APPROVED D. CHAU DCA APPROVED M. ALIM ACAD FILE NUMBER C6646326A.DWG	DATE 08/31/05  09/13/05 09/13/05	 Tyco Electronics Corporation Menlo Park, Ca 94025 	
	TITLE USER INFORMATION COMPLIANT TAIL TERMINATION AND MATED CONDITION			
	SIZE B	DWG NUMBER C = 6646326	REV. A	
	DWG SCALE 1=1		SH 3 OF 3	