

MC9S12A512

Target Applications

- > Instrumentation
- > Energy management
- > Industrial control
- > Robotics
- > Safety equipment
- > Security

Overview

Freescale Semiconductor's MC9S12A512 Flash microcontroller (MCU) is the next generation of the highly successful 68HC12 architecture. Using Freescale's industry-leading 0.25 μ s Flash, the A512 is part of a pin-compatible family that is planned to scale from 32 KB to 512 KB of Flash memory. The MC9S12A512 provides an upward migration path from Freescale's 68HC08, 68HC11 and 68HC12 architectures for applications that need larger memory, more peripherals and higher performance.

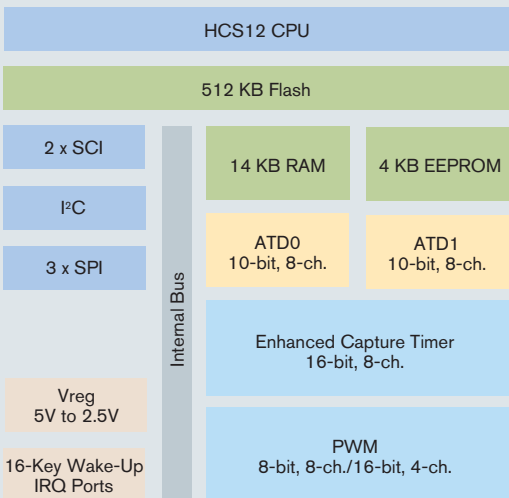

Features

High-Performance 16-bit HCS12 CPU Core

- > 25 MHz bus operation at 5V for 40 ns minimum instruction cycle time

Benefits

- > Opcode compatible with the 68HC11 and 68HC12
- > C-optimized architecture produces extremely compact code

On-Chip Debug Interface

- > Dedicated serial debug interface
- > On-chip breakpoints

- > Real-time in-circuit emulation and debug without expensive and cumbersome box emulators
- > Read/write memory and registers while running at full speed

Integrated Third-Generation Flash Memory

- > In-application reprogrammable
- > Self-timed, fast programming
 - Fast Flash page erase—20 ms (512 bytes)
 - Can program 16 bits in 20 μ s while in burst mode
- > 5V Flash program/erase/read
- > Flash granularity—512 byte Flash erase/2 byte Flash program
- > Four independently programmable Flash arrays
- > Flexible block protection and security

- > Flexibility to change code in the field
- > Efficient end-of-line programming
- > Total program time for 512 KB code is less than 10 seconds
- > Reduces production programming cost through ultra-fast programming
- > No external high voltage or charge pump required
- > Virtual EEPROM implementation, Flash array usable for EE extension
- > Can erase one array while executing code from another

4 KB Integrated EEPROM

- > Flexible protection scheme for protection against accidental program or erase
- > EEPROM can be programmed in 46 μ s

- > Can erase 4 bytes at a time and program 2 bytes at a time for calibration, security, personality and diagnostic information

10-bit Analog-to-Digital Converter (ADC)

- > Two, 8-channel ADCs
- > 7 μ s, 10-bit single conversion time, scan mode available

- > Fast, easy conversion from analog inputs like position sensors, analog meters and photovoltaic cells to digital values for CPU processing
- > ADC run in parallel for a 7 μ s conversion for two 10-bits or, in other words, 3.5 μ s for 10-bits

Features

Benefits

Clock Generation Module with Phase-Lock Loop (PLL)

- | | |
|--|--|
| <ul style="list-style-type: none"> > Clock monitor with limp home mode in case of no external clock > Programmable clock frequency with 1024 options ranging from divide by 16 to multiply by 64 from base oscillator > Slow mode divider > Real-time interrupt > Watchdog | <ul style="list-style-type: none"> > Reliable, robust operation > Provides high performance using low-cost reference crystals > Reduces generated noise > Reduces power consumption > Easily able to implement real-time clock |
|--|--|

Enhanced Capture Timer

- | | |
|---|--|
| <ul style="list-style-type: none"> > 8-channel, 16-bit with input capture, output compare and pulse accumulator > 16-bit modulus down counter | <ul style="list-style-type: none"> > Flexible, programmable timer system |
|---|--|

8-bit or 16-bit Pulse-Wide Modulation (PWM)

- | | |
|--|---|
| <ul style="list-style-type: none"> > 8-channel, 8-bit or 4-channel, 16-bit PWM > PWM supports center-aligned operation | <ul style="list-style-type: none"> > Efficiently implement motor control, battery charging or digital-to-analog (DAC) functions |
|--|---|

Two Serial Communications Interfaces

- > Asynchronous communication between the MCU and a terminal, computer or a network of MCUs

Three Serial Peripheral Interfaces

- > High-speed synchronous communication between multiple MCUs or between MCU and serial peripherals

Inter IC (I²C) Bus

- > Provides a simple, efficient method of data exchange between devices
- > Minimizes the need for large numbers of connections between devices and eliminates the need for an address decoder

Up to 91 Input/Output (I/O) Lines

- | | |
|---|--|
| <ul style="list-style-type: none"> > Programmable pull-ups/pull-downs > Dual drive capability | <ul style="list-style-type: none"> > Reduce system cost > Able to tailor application for minimum EMC or high current loads |
|---|--|

Application Notes and Engineering Bulletins

- | | |
|--------|---|
| AN2206 | Security and Protection on the HCS12 Family |
| AN2213 | Using Cosmic Software's M68HC12 Compiler for MC9S12DP256 Software Development |
| AN2216 | MC9S12DP256 Software Development Using Metrowerks CodeWarrior™ |
| AN2250 | Audio Reproduction on HCS12 Microcontrollers |
| EB386 | HCS12 D-Family Compatibility |

Learn More: For more information about Freescale products, please visit www.freescale.com.

Data Sheets

9S12DP512DGV1	9S12DX512 Device Guide
S12BDMV4	HCS12 Background Debug (BDM) Block Guide
S12BKVD1	HCS12 Breakpoint (BKP) Block Guide
S12CPUV2	HCS12 CPU Reference Manual
S12ATD10B8CV2	HCS12 10-bit, 8-Channel Analog to Digital Converter (ADC) Block Guide
S12BDLCV1	HCS12 Byte Data Link Controller (BDLC) Block Guide
S12CRGV4	HCS12 Clocks and Reset Generator (CRG) Block
S12DP256PIMV3	9S12DP256 Port Integration Module (PIM)
S12ECT16B8CV1	HCS12 16-bit, 8-Channel Enhanced Capture Timer (ECT) Block Guide
S12EETS4KV2	HCS12 4K EEPROM Block Guide
S12FTS512K4V1	HCS12 512K Flash Block Guide
S12IICV2	HCS12 I ² C Block Guide
S12INTV1	HCS12 Interrupt (INT) Block Guide
S12MEBIV3	HCS12 Multiplexed External Bus Interface (MEBI) Block Guide
S12MMCV4	HCS12 Module Mapping Control (MMC) Block Guide
S12PWM8B8CV1	HCS12 8-bit, 8-Channel Pulse Width Modulator (PWM) Block Guide
S12SCIV2	HCS12 Serial Communications Interface (SCI) Block Guide
S12SPIV3	HCS12 Serial Peripheral Interface (SPI) Block Guide
S12VREGV1	HCS12 Voltage Regulator Block Guide

Cost-Effective Development Tools

For more information on development tools, please refer to the Freescale Development Tool Selector Guide (SG1011).

M68KIT912DP256 \$495	Evaluation kit for development and evaluation of HCS12 application code that includes the M68EVB912DP256 and USBMULTILINKBDM
M68CYCLONEPRO \$499	HC08/HCS08/HC12/HCS12 stand-alone Flash programmer or in-circuit emulator, debugger, Flash programmer; USB, serial or Ethernet interface options
USBMULTILINKBDM \$99	Universal HCS08/HCS12 in-circuit emulator, debugger, and Flash programmer; USB PC interface
CWX-H12-SE Free	CodeWarrior™ Special Edition for HCS12 MCUs; includes integrated development environment (IDE), linker, debugger, unlimited assembler, Processor Expert™ auto-code generator, full-chip simulation and limited C compiler

Package Options

Part Number	Package	Temp. Range
MC9S12A512CPV	112 LQFP	-40°C to +85°C

