

P1

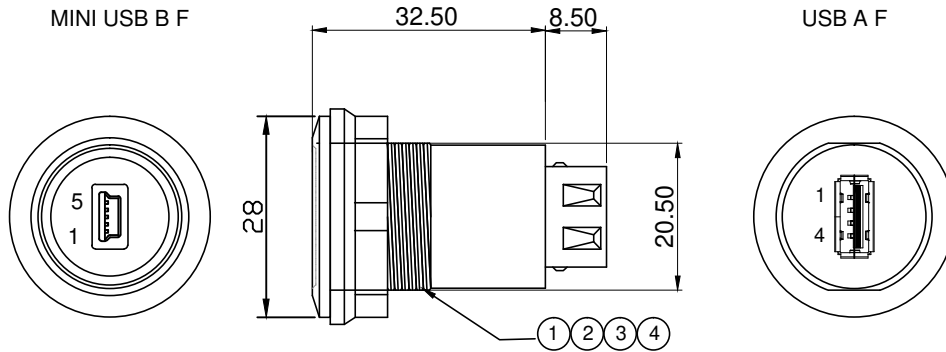

P2

PIN ASSIGNMENT

P1	P
1-----	1
2-----	2
3-----	3
5-----	4
S-----	S

NOTES:
 1. PIN ASSIGNMENT SEE TO WIRE LIST.
 2. ELECTRICAL TEST CONDITION:
 (a).100%OPEN,SHORT & MISWIRE TEST,
 (b). INSULATOR RESISTANCE:10 Mohm MIN.
 DC 300V 0.01sec.
 (c). CONTACT RESISTANCE:3ohm MAX.

3	NUT BLACK PVC 27P MOLDED.	
3	PVC 45P BLACK.	
2	USB A F WHITE PBT WITH NICKLE PLATED SHELL G/F.	
1	MINI USB B F BLACK PBT WITH NICKLE PLATED SHELL G/F.	
NO.	Description	P/N

DWG NO:	PCM-0159	GOODS CODE		Draw	Jason	Date	2019/3/13
ITEM NO.		DRAWING EVIDENCE		Check		Date	
Goods NO.				Approval		Date	
Original NO.		Unit(mm)					

PREMIER CABLE MFG CO LTD	D		
	C		
	B		
	VER.A	REVISE	Date.