

D-7, DH-7 and DH-18 Series, Rated up to 50 Amps, 28 Vdc

Product Facts

- 2 SPST, 1 NO, 1 NC
- DH-18 Series are center-off double-throw units
- Gasket Sealed or Hermetically Sealed
- Auxiliary contacts available
- Meets many requirements of MIL-R-6106



Performance Data

Electrical Characteristics

Contact Arrangement — 2 SPST, 1 NO, 1 NC, Electrically Latched
Rated Operating Voltage — 28 Vdc
Resistive Rating — 50 Amps
Inductive Rating — 25 Amps

General Characteristics

Temperature Range — -55°C to +71°C
Operating Cycles (Life) at Rated Resistive Load, Min. — 50,000 cycles
Operating Cycles (Life) Mechanical, Min. — 100,000 cycles
Dielectric Strength — All Circuits to Ground — 1,500 Vrms
 Circuit to Circuit — 1,500 Vrms
 Coil to Ground and Aux. Contacts — 1,000 Vrms
Altitude Max. — 50,000 ft.
Weight — .72 to .94 lbs

Coil Characteristics

Duty Cycle — Continuous (Type A, See diagram below) or Continuous with suppression (Type B, See diagram below) or Continuous (Type C)
Operating Voltage, Nom. — 28 Vdc
Pickup Voltage @ 25°C, Max. — 18 Vdc
Dropout Voltage @ 25°C, Max. — 1.5 to 7 Vdc
Coil Current @ 25°C, Max. — 0.28 Amp

Coil Type

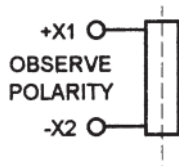

A — Continuous

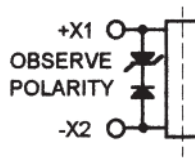

B — Continuous with Suppression

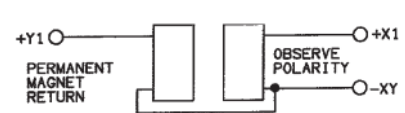

C — Continuous

For factory-direct application assistance, phone 419-521-9500 or fax 419-526-2749.

D-7, DH-7 and DH-18 Series, Rated up to 50 Amps, 28 Vdc (Continued)

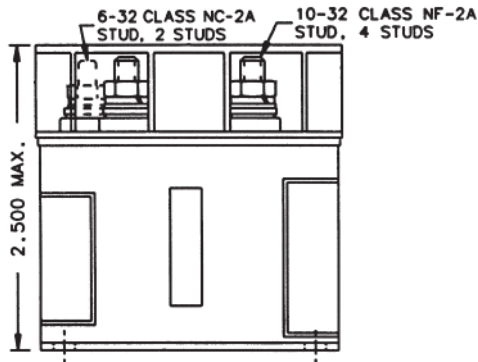
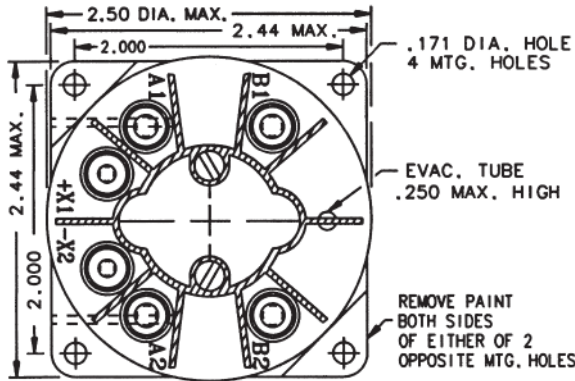

Mounting Style A

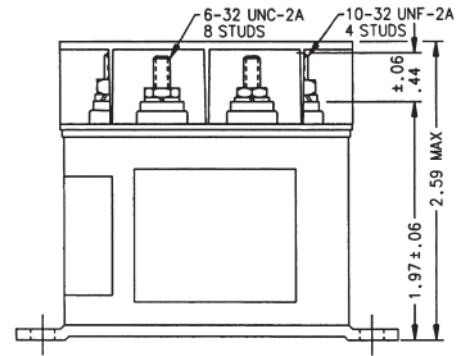
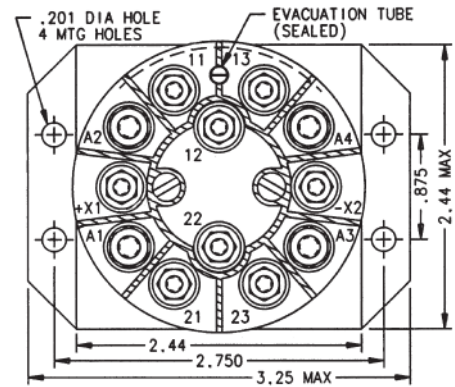

Mounting Style B

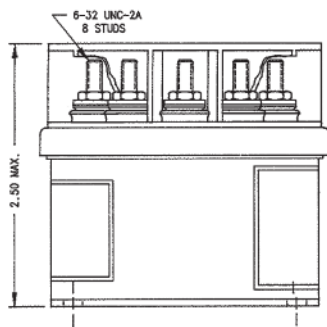
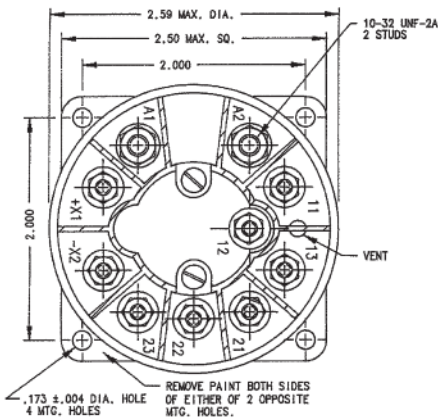

Mounting Style C

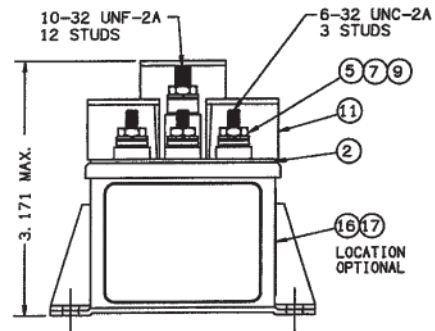
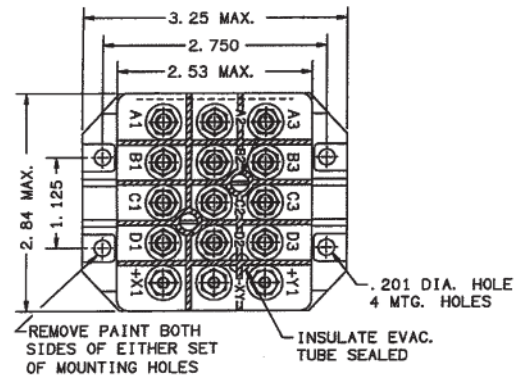

Mounting Style D

For factory-direct application assistance, phone 419-521-9500 or fax 419-526-2749.

D-7, DH-7 and DH-18 Series, Rated up to 50 Amps, 28 Vdc (Continued)

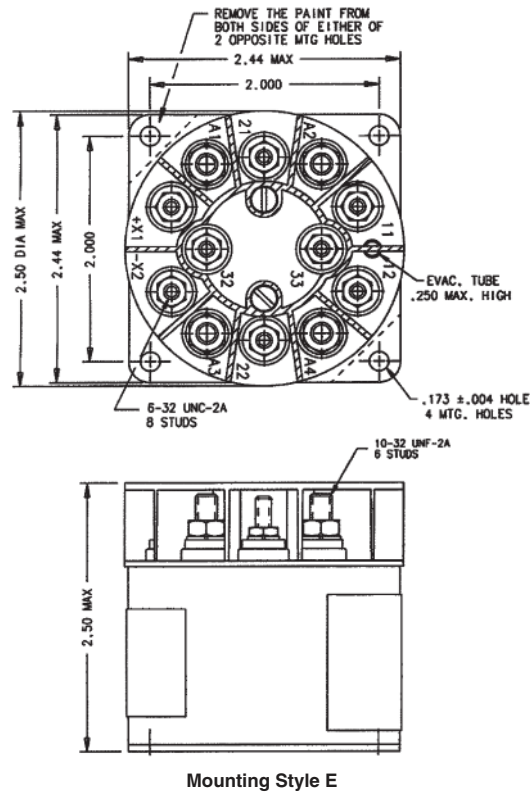

For factory-direct application assistance, phone 419-521-9500 or fax 419-526-2749.

D-7, DH-7 and DH-18 Series, Rated up to 50 Amps, 28 Vdc (Continued)

Circuit Configurations (Consult factory for other available circuit configurations)

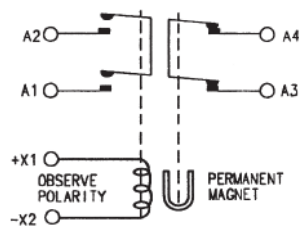

Circuit Configuration 1

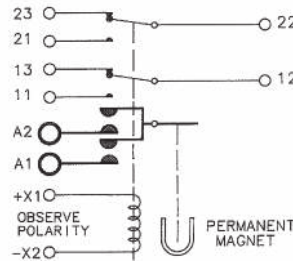

Circuit Configuration 2

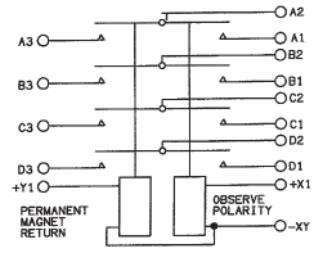

Circuit Configuration 3

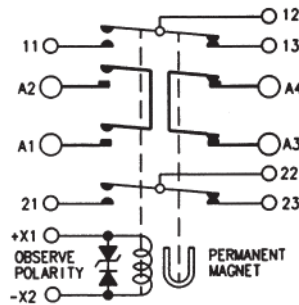

Circuit Configuration 4

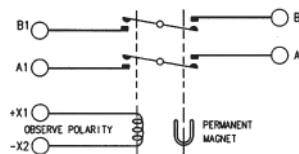

Circuit Configuration 5

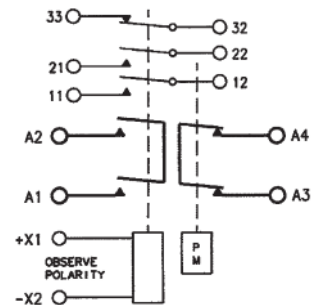

Circuit Configuration 6

HARTMAN Part Number	Construction Type	Mounting Style	Coil Type	Circuit Config.	TE Part Number
D-7AC	Gasket Sealed	A	A	1	1616088-1
D-7LHB	Gasket Sealed	C	A	2	1616064-1
DH-18DA*	Hermetically Sealed	D	C	3	1616050-2
DH-7ATK	Hermetically Sealed	B	B	4	1616089-7
DH-7MN	Hermetically Sealed	A	A	5	1616103-2
DH-7TB	Hermetically Sealed	E	A	6	1-1616089-3

*DH-18DA is a 4PDT center-off unit. Contacts will return to the center position when coil power is removed.

For factory-direct application assistance, phone 419-521-9500 or fax 419-526-2749.