



LOW NOISE, HIGH IP3

# Monolithic Amplifier

PSA-0012+

Mini-Circuits

50Ω 0.05 to 6 GHz

## THE BIG DEAL

- Ideal IF Amplifier
- Low Noise Figure, 2.4 dB typ. at 1 GHz
- High IP3, up to 34 dBm typ. at 1 GHz
- Output Power at 1dB comp., up to +22 dBm typ.
- Gain, 16 dB typ. at 1 GHz
- Micro-miniature size SOT-363 package
- High Output Power
- Wide band
- May be used as replacement for M/A COM MAALSS0012<sup>a,b</sup>



Generic photo used for illustration purposes only

CASE STYLE: CA1389

### +RoHS Compliant

The +Suffix identifies RoHS Compliance. See our web site for RoHS Compliance methodologies and qualifications

## APPLICATIONS

- Cellular
- ISM
- GSM
- WCDMA
- LTE
- WiMax
- WLAN
- UNII and HIPERLAN

## PRODUCT OVERVIEW

The PSA-0012+ is an advanced wide band, high dynamic range, low noise, high IP3, high output power, monolithic amplifier. Manufactured using E-PHEMT\* technology enables it to work with a single positive supply voltage.

## KEY FEATURES

Feature	Advantages
Ideal Combined Performance Low Noise: 2.3 dB High IP3: +35 dBm High P1dB: +22 dBm Low Gain: 15dB	The PSA-0012+ design is optimized for use in critical IF Amplifier applications having an ideal combination of Low Gain, Low Noise, and High Output Power.
Wide band operation 50 MHz to 6000 MHz	Operating over a broad frequency range, the PSA-0012+ covers a wide range of typical IF bands making this amplifier ideal for use in a variety of applications.
Excellent Return Loss Input: 12 dB up to 4 GHz Output: 15 dB up to 5 GHz	With 12 dB input and 15 dB output return loss, the PSA-0012+ can be integrated into critical circuits with confidence that VSWR interactions with input and output components will have minimum affect on performance.
May be a replacement for MAALSS0012 <sup>a,b</sup>	The PSA-0012+ is pin-for-pin compatible with the M/A-Com IF Amplifier and provides comparable performance making it an ideal replacement.

\* Enhancement mode pseudomorphic High Electron Mobility Transistor.

A. Suitability for model replacement within a particular system must be determined by and is solely the responsibility of the customer based on, among other things, electrical performance criteria, stimulus conditions, application, compatibility with other components and environmental conditions and stresses.

B. The M/A COM part number is used for identification and comparison purposes only.

REV. B  
ECO-011279  
PSA-0012+  
NY-MCL  
230713





LOW NOISE, HIGH IP3

# Monolithic Amplifier

PSA-0012+

Mini-Circuits

## ELECTRICAL SPECIFICATIONS<sup>(1)</sup> AT 25°C, ZO=50Ω

Parameter	Condition (GHz)	Min.	Typ.	Max.	Units
Frequency Range		0.05		6.0	GHz
at DC Volts (Vd)			5.0		V
DC Current (Id)		60	74	100	mA
Noise Figure	0.05		2.9	—	dB
	0.5		2.3	—	
	1.0		2.3	—	
	2.0		2.4	3.0	
	3.0		2.5	—	
	4.0		2.8	—	
	5.0		3.2	—	
Gain	0.05	—	18.2	—	dB
	0.5	—	16.4	—	
	1.0	14.1	15.7	17.3	
	2.0	—	14.2	—	
	3.0	—	12.9	—	
	4.0	—	11.8	—	
	5.0	—	10.6	—	
Input Return Loss	0.05-0.5		11		dB
	0.5-4.0		12		
	4.0-6.0		9		
Output Return Loss	0.05-0.2		12		dB
	0.2-5		15		
	5-6		11		
Output IP3	0.05		31.7		dBm
	0.5		33.8		
	1.0		33.9		
	2.0		35.0		
	3.0		35.1		
	4.0		35.8		
	5.0		35.4		
6.0		35.1			
Output Power @1dB compression <sup>(2)</sup>	0.05		21.7		dBm
	0.5		21.8		
	1.0		21.8		
	2.0		22.0		
	3.0		22.1		
	4.0		22.1		
	5.0		21.9		
6.0		21.2			
Thermal Resistance			137		°C/W





LOW NOISE, HIGH IP3

# Monolithic Amplifier

PSA-0012+

## MAXIMUM RATINGS<sup>(3)</sup>

Parameter	Ratings
Operating Temperature <sup>(4)</sup>	-40°C to 85°C
Storage Temperature	-65°C to 150°C
Junction Temperature	160°C
DC Voltage (Pin 6)	6
Device Current (Pin 6)	110 mA
Power Dissipation	550 mW
Input Power (CW)	0.05-3GHz 14dBm 3-6GHz 19dBm

- (1) Measured on Mini-Circuits Characterization test board TB-539+ See Characterization Test Circuit (Fig. 1)
- (2) Current increases at P1dB
- (3) Permanent damage may occur if any of these limits are exceeded. These ratings are not intended for continuous normal operation.
- (4) Defined with reference to ground lead temperature.
- (5) Termination, 50 ohms

## SIMPLIFIED SCHEMATIC AND PIN DESCRIPTION

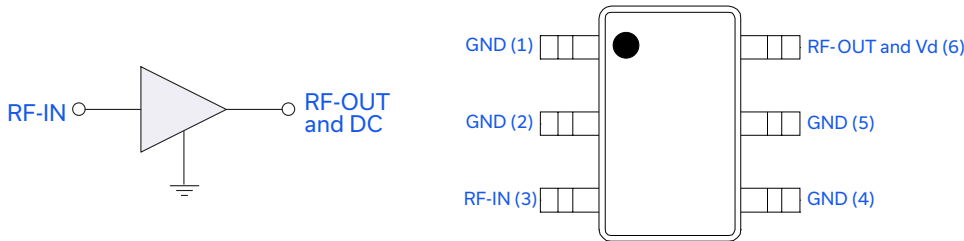

Function	Pin Number	Description (See Application Circuit, Fig. 2)
RF-IN	3	RF input pin (connect to RF-IN via DC blocking cap)
RF-OUT & Vd	6	RF output pin (connected to RF-out via blocking cap C2 and supply voltage Vd via RF Choke L1)
GND	1,2,4,5	Connections to ground





### CHARACTERIZATION TEST CIRCUIT

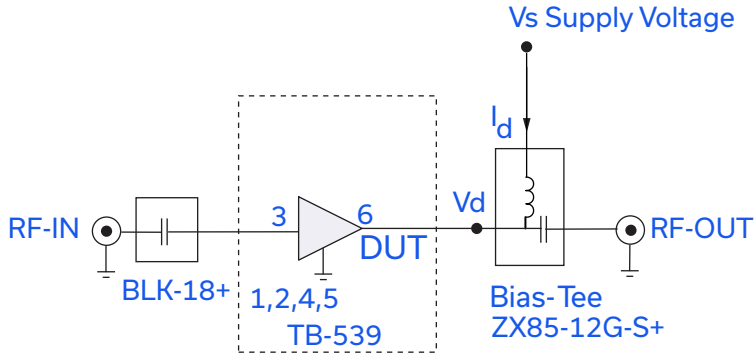

Fig 1. Block Diagram of Test Circuit used for characterization. (DUT soldered on Mini-Circuits Test Board TB-539+) Gain, Return loss, Output power at 1dB compression (P1 dB), Output IP3 (OIP3) and Noise Figure measured using Agilent's N5242A PNA-X microwave network analyzer.

Conditions:

1. Gain: Pin= -25dBm
2. Output IP3 (OIP3): Two tones, spaced 1 MHz apart, 5 dBm/ tone at output.
3. Vs adjusted for 5V at device (Vd), compensating loss of bias tee.

### RECOMMENDED APPLICATION CIRCUIT

(refer to evaluation board for PCB Layout and component values)

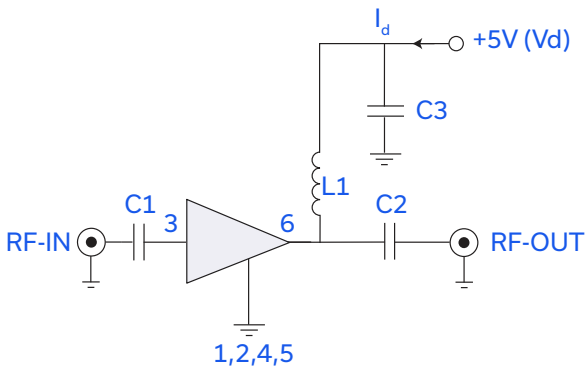
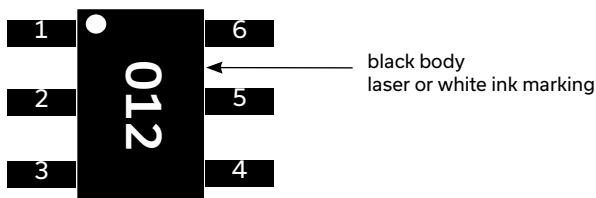

Fig 2. Recommended Application Circuit  
Note: Resistance of L1, 0.1-0.2Ω typically

### PRODUCT MARKING



Marking may contain other features or characters for internal lot control



ADDITIONAL DETAILED TECHNICAL INFORMATION IS AVAILABLE ON OUR DASH BOARD. TO ACCESS [CLICK HERE](#)

Performance Data	Data Table Swept Graphs S-Parameter (S2P Files) Data Set (.zip file)
Case Style	CA1389 Plastic molded SOT-363 package, lead finish: matte tin
Tape & Reel Standard quantities available on reel	F101 Standard quantities available on reel: 7" reels with 20, 50, 100, 200, 500, 1K, or 2K devices.
Suggested Layout for PCB Design	PL-316
Evaluation Board	TB-541+
Environmental Ratings	ENV08T2

### ESD RATING

Human Body Model (HBM): Class 0 (<250V) in accordance with ANSI/ESD STM 5.1 - 2001; passes 150V

Machine Model (MM): Class M1 (<100V) in accordance with ANSI/ESD STM5.2-1999; passes 25V

### MSL RATING

Moisture Sensitivity: MSL1 in accordance with IPC/JEDEC J-STD-020D

### MSL TEST FLOW CHART

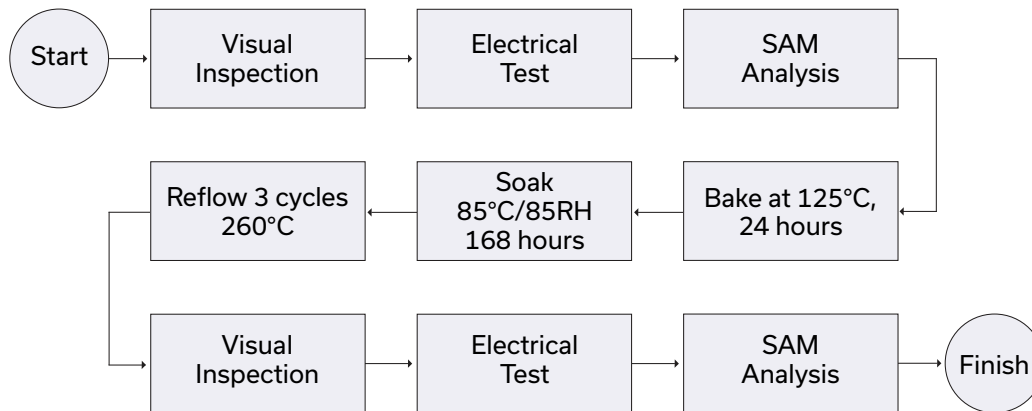

- NOTES**
- A. Performance and quality attributes and conditions not expressly stated in this specification document are intended to be excluded and do not form a part of this specification document.
  - B. Electrical specifications and performance data contained in this specification document are based on Mini-Circuit's applicable established test performance criteria and measurement instructions.
  - C. The parts covered by this specification document are subject to Mini-Circuits standard limited warranty and terms and conditions (collectively, "Standard Terms"); Purchasers of this part are entitled to the rights and benefits contained therein. For a full statement of the standard. Terms and the exclusive rights and remedies thereunder, please visit Mini-Circuits' website at [www.minicircuits.com/MCLStore/terms.jsp](http://www.minicircuits.com/MCLStore/terms.jsp)