

## 5V/20A, active clamp forward converter, Power Over Ethernet (PoE) - IEEE 802.3bt compliant reference design

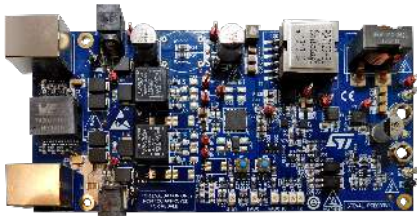

### Features

- Features of **PM8805** PoE-PD interface
  - System in package integrating a double active bridge, hot-swap MOSFET and PoE-PD interface
  - PoE-PD single-signature interface compliant with IEEE 802.3bt
  - Detection and support of high power 4-pair applications
  - 100 V N-Ch MOSFETs with 0.2  $\Omega$  total path resistance for each active bridge
  - Identifies which kind of PSE (standard or legacy) it is connected to and provides successful IEEE802.3.af/at/bt classification indication through a combination of the T0, T1 and T2 signals (open drain)
  - VFQFPN43 8x8 mm with 6 exposed pads
- Features of **PM8804** PWM controller
  - PWM peak current mode controller
  - Input operating voltage up to 75 V
  - Internal high voltage start up regulator with 20 mA capability
  - Programmable fixed frequency up to 1 MHz
  - Soft start up with settable time
  - Soft turn off (optionally disabled)
  - Dual 1Apk, low side complementary gate drivers
  - GATE2 optionally turned off for reduced consumption
  - 80% maximum duty cycle with internal slope compensation
  - VFQFPN 3.0x3.0x1.0 16L 0.5 mm pitch
- WEEE compliant
- RoHS compliant

Product summary	
high power PoE PD / 5 V up to 20 A active clamp forward evaluation board	STEVAL-POE003V1
PWM peak current mode controller for PoE and telecom systems	PM8804
IEEE802.3bt PoE-PD interface with integrated dual-active bridge	PM8805

### Description

This reference design represents a PoE Class 8 converter designed for high efficiency conversion over a wide load range. It is based on the **PM8805** PoE-PD interface compliant with the IEEE802.3bt standard, and a DC-DC forward active clamp converter driven by the **PM8804** PWM controller.

The **PM8805** system on package device embeds two active bridges and an IEEE802.3bt compliant Powered Device (PD) interface. It can be used in all medium-to-high power 2P and 4P high efficiency PoE and PoE+ applications such as point of sales and retail logistics devices.

The **PM8804** PWM controller represents an integrated solution for a smart and efficient 48 V converter, including a programmable oscillator for the switching frequency, adjustable slope compensation, dual complementary low-side drivers with programmable dead time, programmable soft start, soft turn off and a programmable current sense blanking time.

# 1 Specifications

**Table 1. Specifications**

Parameter	Specs
Classification	Class 8
Vin at RJ45 connector (J1)	From 41.2 to 57 V
Iin at RJ45 connector (J1)	1.0 A max each pair
Vout	5 V +/- 2%
Iout	20 A total max
Max output power	100 W max
Efficiency overall peak	> 92% @ 13 A
Vin at frontal jack connector (J9)	48 V +/- 2 V
Iin at frontal jack connector (J9)	2.0 A total max
Vin at rear jack connector (J10)	48 V +/- 2 V
Iin at rear jack connector (J10)	2.5 A total max
Operating temperature	0 - 50 °C 20 A full load

## 2 System board layout

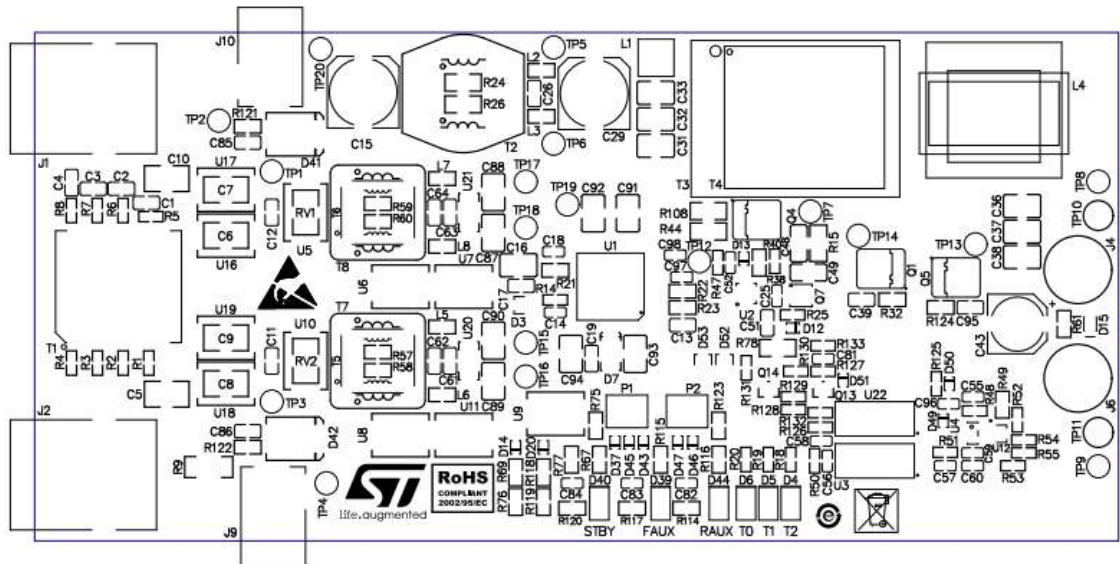
**Figure 1. PCB top assembly**

### 3 Efficiency measurements

The **STEVAL-POE003V1** consists of a POE interface compliant with the last standard IEEE802.3bt, created with the **PM8805** interface and a forward active clamp DC-DC converter that receives a DC voltage from POE interface.

PM8805 device integrates two N-channel MOSFET bridges, one for every 2-pair of the POE interface, and an hotswap MOSFET placed in series with the outputs of two bridges.

The following figure shows the efficiency of the single forward converter, and the overall efficiency that also includes the power losses of the POE interface.

**Figure 2. STEVAL-POE003V1 efficiency measurements**

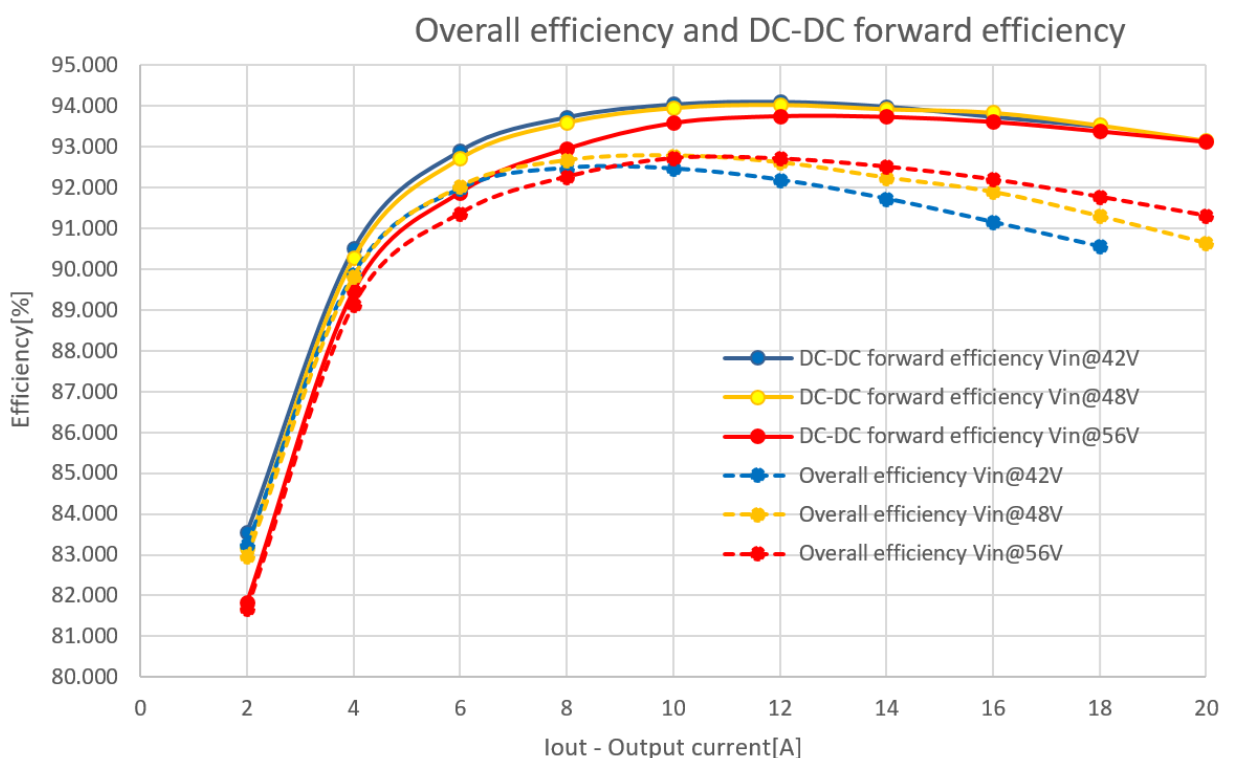

The dotted lines give the overall efficiency of the STEVAL-POE003V1 at different DC input voltages applied to RJ45 connector J1. The continuous lines show the DC-DC forward efficiency, representing a figure of merit of the standalone converter. The following losses relating to the POE interface are not included:

- RJ45 connector J1
- POE data transformer T1
- Common chokes T7, T8 placed on the two power supplies pairs
- PM8805 interface that integrates dual power mos bridges and a hot swap MOSFET
- Input filter of the forward converter

This efficiency is measured between output test points TP8/TP9 and input test points TP5/TP6 of the forward converter.

## 4 STEVAL-POE003V1 schematic diagrams

Figure 3. STEVAL-POE003V1 circuit schematic (1 of 3)

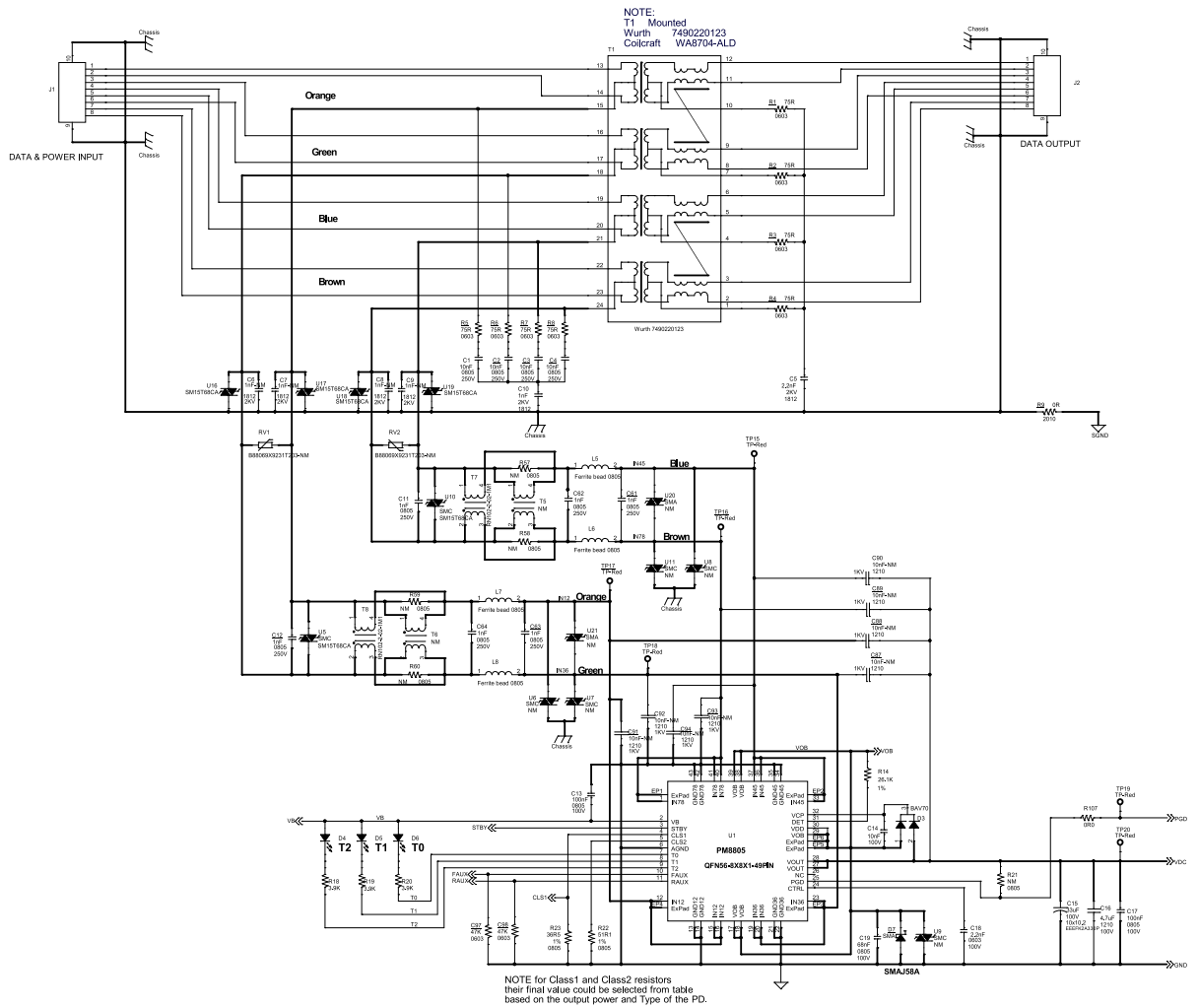

NOTE for Class1 and Class2 resistors  
their final value could be selected from table  
based on the output power and Type of the PD.

PD Requested Class	Number of PSE class events	Assigned Class	Power Available at the PD PI	Outputs	
				T0	T1
any	0	0	13.0 W	1	1
0	1	0	13.0 W	1	1
1	1	1	3.84 W	1	1
2	1	2	6.49 W	1	1
3 to 8	1	3 or 0	13.0 W	1	1
4 to 8	2 or 3	4	25.5 W	0	1
5	4	5	40.0 W	1	0
6 to 8	4	6	51.0 W	1	0
7	5	7	62.0 W	0	0
8	5	8	71.3 W	0	0

PD class	CLS1 resistor (Ω)	CLS2 resistor (Ω)	Min (mA)	Max (mA)
Class 0	2k	2k	0	4.0
Class 1	150	150	9.0	12.0
Class 2	80.6	80.6	17.0	20.0
Class 3	51.1	51.1	26.0	30.0
Class 4	36.5	36.5	36.0	44.0
Class 5	36.5	2k	36.70	44.74
Class 6	36.5	150	36.79	44.712
Class 7	36.5	80.6	36.717	44.720
Class 8	36.5	51.1	36.726	44.730

NOTE for Resistors  
Where not indicated the body is 0603 and tolerance 5%

NOTE for Capacitors  
Where not indicated the body is 0603, the voltage is 100V material X7R and tolerance 10%, 100nF 100V is X7R 10% 0805.

Figure 4. STEVAL-POE003V1 circuit schematic (2 of 3)

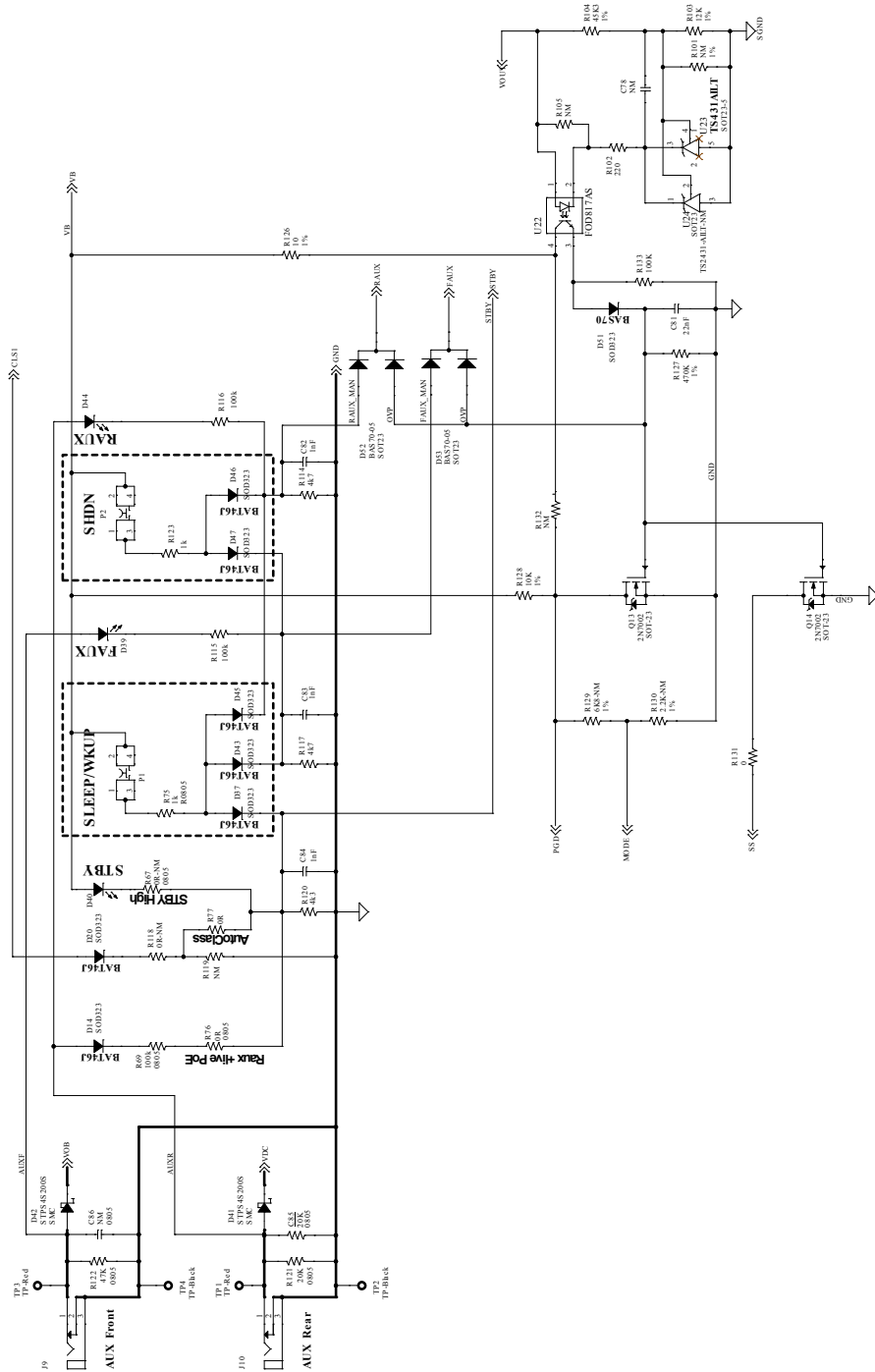
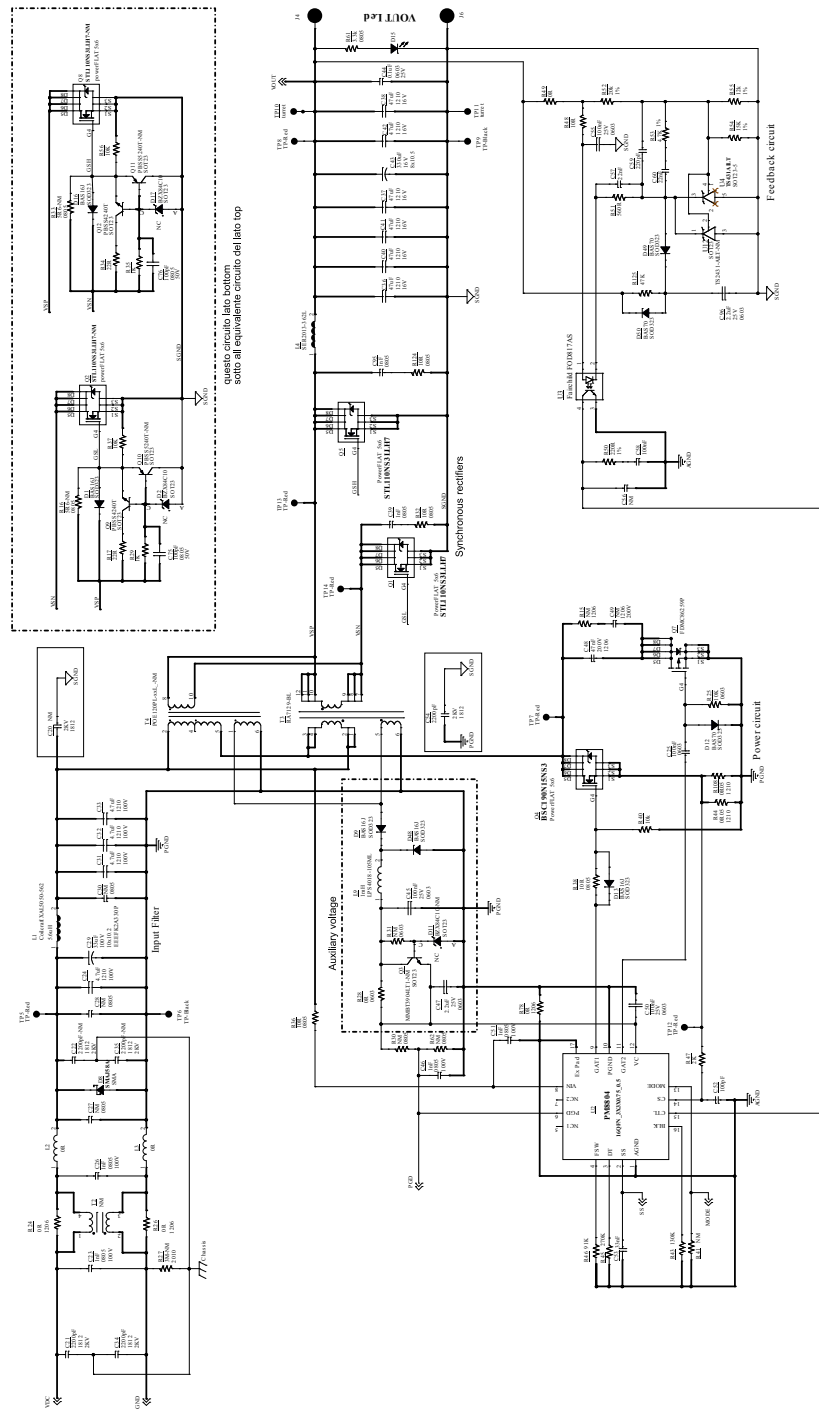

Figure 5. STEVAL-POE003V1 circuit schematic (3 of 3)



## Revision history

**Table 2. Document revision history**

Date	Version	Changes
18-Oct-2018	1	Initial release.
03-May-2019	2	Updated document title. Minor changes to cover page <a href="#">Features</a> and <a href="#">Description</a> .



## Contents

<b>1</b>	<b>Specifications .....</b>	<b>2</b>
<b>2</b>	<b>System board layout.....</b>	<b>3</b>
<b>3</b>	<b>Efficiency measurements .....</b>	<b>4</b>
<b>4</b>	<b>STEVAL-POE003V1 schematic diagrams .....</b>	<b>5</b>
	<b>Revision history .....</b>	<b>8</b>

## List of tables

<b>Table 1.</b>	Specifications . . . . .	2
<b>Table 2.</b>	Document revision history . . . . .	8

## List of figures

<b>Figure 1.</b>	PCB top assembly . . . . .	3
<b>Figure 2.</b>	STEVAL-POE003V1 efficiency measurements . . . . .	4
<b>Figure 3.</b>	STEVAL-POE003V1 circuit schematic (1 of 3) . . . . .	5
<b>Figure 4.</b>	STEVAL-POE003V1 circuit schematic (2 of 3) . . . . .	6
<b>Figure 5.</b>	STEVAL-POE003V1 circuit schematic (3 of 3) . . . . .	7

**IMPORTANT NOTICE – PLEASE READ CAREFULLY**

STMicroelectronics NV and its subsidiaries (“ST”) reserve the right to make changes, corrections, enhancements, modifications, and improvements to ST products and/or to this document at any time without notice. Purchasers should obtain the latest relevant information on ST products before placing orders. ST products are sold pursuant to ST’s terms and conditions of sale in place at the time of order acknowledgement.

Purchasers are solely responsible for the choice, selection, and use of ST products and ST assumes no liability for application assistance or the design of Purchasers’ products.

No license, express or implied, to any intellectual property right is granted by ST herein.

Resale of ST products with provisions different from the information set forth herein shall void any warranty granted by ST for such product.

ST and the ST logo are trademarks of ST. For additional information about ST trademarks, please refer to [www.st.com/trademarks](http://www.st.com/trademarks). All other product or service names are the property of their respective owners.

Information in this document supersedes and replaces information previously supplied in any prior versions of this document.

© 2019 STMicroelectronics – All rights reserved