

STANDARD SPECIFICATIONS	
PARAMETERS	MAX (Unless otherwise noted)
Frequency Range	32.768 kHz
Frequency Tolerance @ 25°C	(See options below)
Frequency Stability, ref 25°C (Temperature Coefficient)	-0.04 PPM / (Δ°C) ²
Temperature Range	
Turnover (T _O)	+20°C ~ +30°C
Operating (T _{OPR})	-40°C ~ +85°C
Storage (T _{STG})	-55°C ~ +125°C
Equivalent Series Resistance (R _S)	50 kΩ
Load Capacitance (C _L)	(See options below)
Insulation Resistance @ 100V _{DC}	500 MΩ Min
Drive Level	1.0 μW 0.1 μW typ
Aging per year @ 25°C	±3 PPM
Maximum Soldering Temp / Time	260°C / 10 Seconds x2
Moisture Sensitivity Level (MSL) per J-STD-033	1
Termination Finish	Au over Ni
Seal Method	Seam
Lead (Pb) Free	Yes
RoHS Compliant	Yes

DIMENSIONS / MECHANICAL SPECIFICATIONS

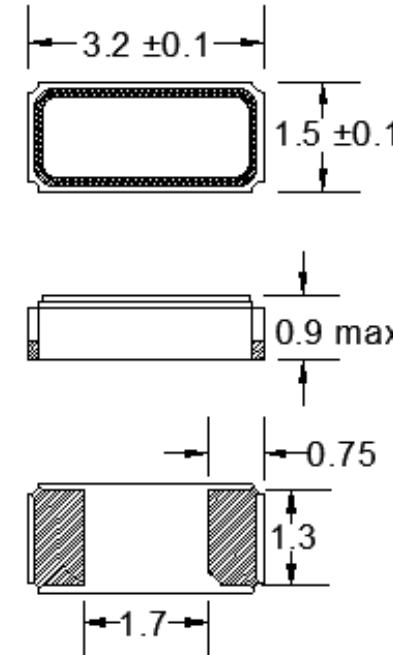

Recommended Solder Pad Layout

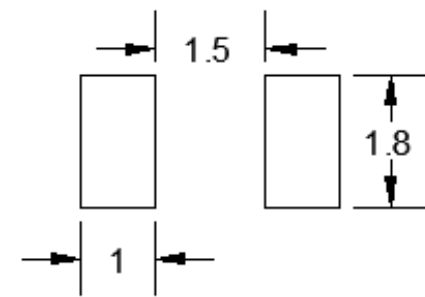

Dimensions in mm

Note: Dimensional drawing is for reference to critical specifications defined by size measurements. Certain non-critical visual attributes, such as side castellations, etc. may vary.

Temperature Coefficient

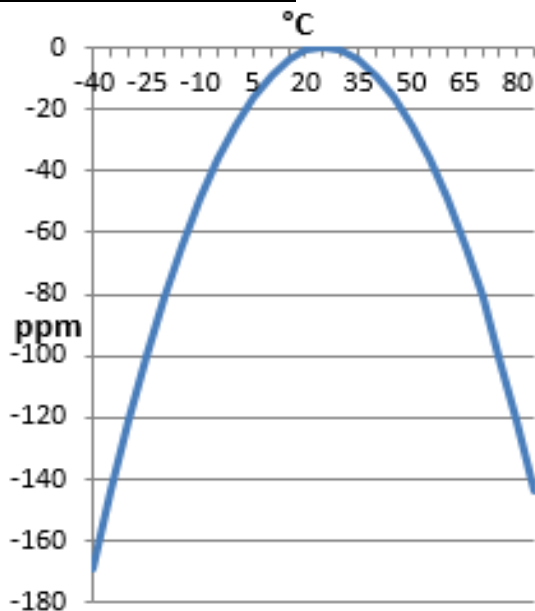

FK13L

(Former FX135L)

3.2mm x 1.5mm

SMD Tuning Fork, Low ESR



TAPE SPECIFICATIONS (mm)							REEL SPECIFICATIONS (mm)						
A	B	C	D	E	F	REEL QTY	G	H	I	J	K	L	M
Ø1.5	4.0	4.0	5.5	12.0	1.0	-T3 = 3,000	2.0	Ø13	Ø21	Ø60	Ø180	13.0	1.2

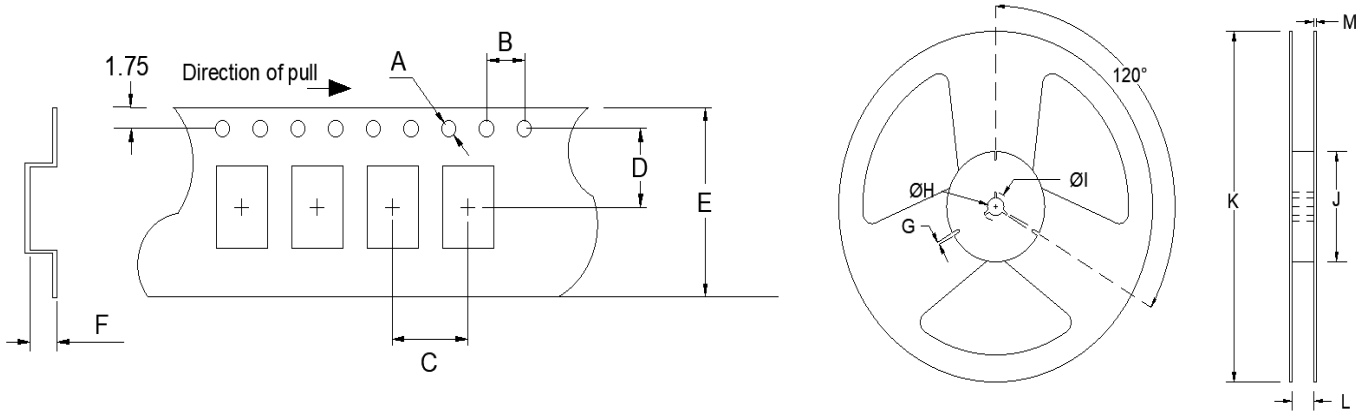

Available Options & Part Identification for SMD Tuning Fork Crystal K13L

Sample PN: **FK13LEIHM0.032768-T3**

F	K13L	E	I	H	M	0.032768	-T3
Fox	Model Number	Tolerance E = ±20 PPM H = ±10 PPM	Stability I = -0.04 PPM/ (Δ°C) ²	Load Capacitance B = 6pF H = 12.5PF	Operating Temperature M = -40 ~ +85 °C	Frequency (MHz)	Values Added Options Blank = Bulk T3 = 3,000 pcs

Reliability Test Conditions

Please contact Abracon Quality Assurance department

Crystal Unit Handling Precautions

1) Mounting Precautions

- If the board is deformed, such as bending after mounting, peeling of the soldered joint between the crystal resonator and board may occur producing a crack in the ceramic package, leading to loss of vacuum, destruction of the internal element, etc. Especially when repaneling the board on which it is mounted, there is a possibility that a large stress may be applied, please consider board layout and cutting method to minimize stress on products.
- When the product is automatically mounted on the board, if a large impact is applied to the crystal resonator, there is a possibility that characteristics may change / deteriorate, or the product may be broken. When mounting automatically, please set conditions considering the shock to the crystal unit. Also, please conduct the mounting test beforehand and confirm that there is no influence on the characteristics to the crystal resonator.
- Cracks may occur in the soldered part by repeated harsh temperature changes for a long time when mounting due to the board having a expansion coefficient different from that of the ceramics used in the crystal package. When using under such circumstances, please conduct test beforehand and confirm that there is no influence on the crystal unit.
- Ceramic packages are small and thin products. So, if/when you rework after mounting, please give consideration to the selection and handling of the tools to be used.

2) Soldering

Following is typical SMD Pb-free reflow profile for soldering:

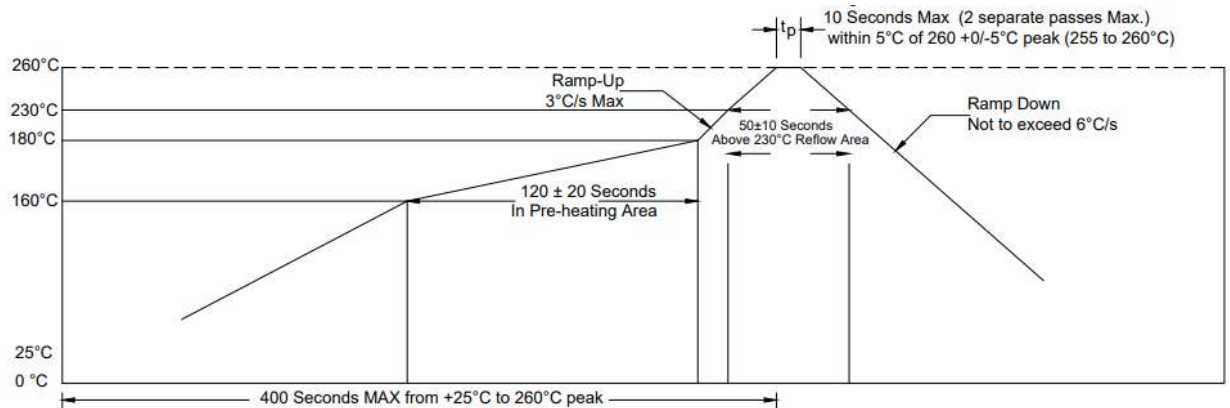

Excessive heating time at high temperature may result in deterioration of the characteristics and may break the crystal unit. For manual rework, heat the lead part at 300°C or lower for 5 seconds or less.

3) Cleaning

Since a small, thin crystal chip is used for tuning fork crystal units and the frequency approximates that of an ultrasonic cleaner, the crystal chip may break easily. Therefore, DO NOT perform ultrasonic cleaning.