

THIS DRAWING IS UNPUBLISHED. RELEASED FOR PUBLICATION  
 © COPYRIGHT BY TYCO ELECTRONICS CORPORATION. ALL RIGHTS RESERVED.

LOC	DIST	REVISIONS			
P	LTR	DESCRIPTION	DATE	DWN	APVD
AD	00	T	OG3C-0324-01	12OCT01	RB JO

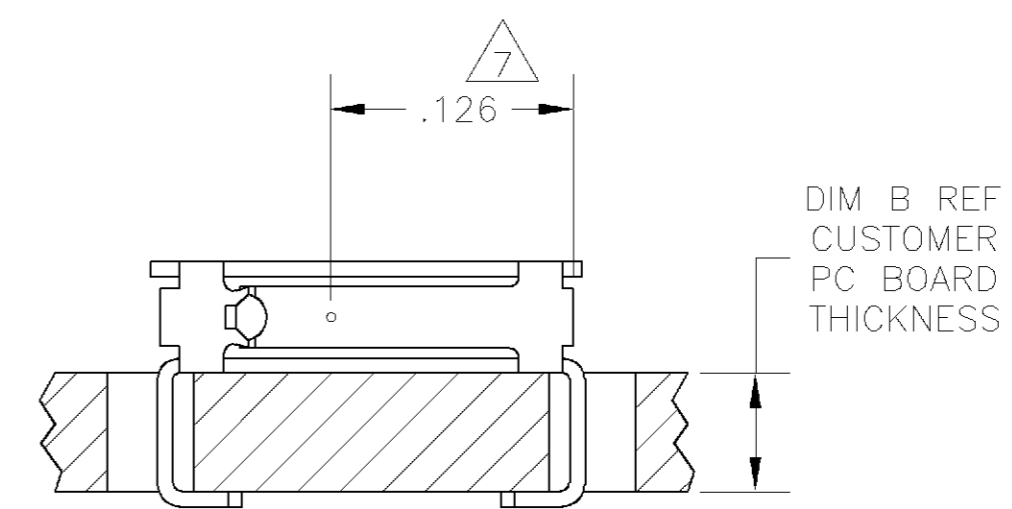

TYPICAL APPLICATION

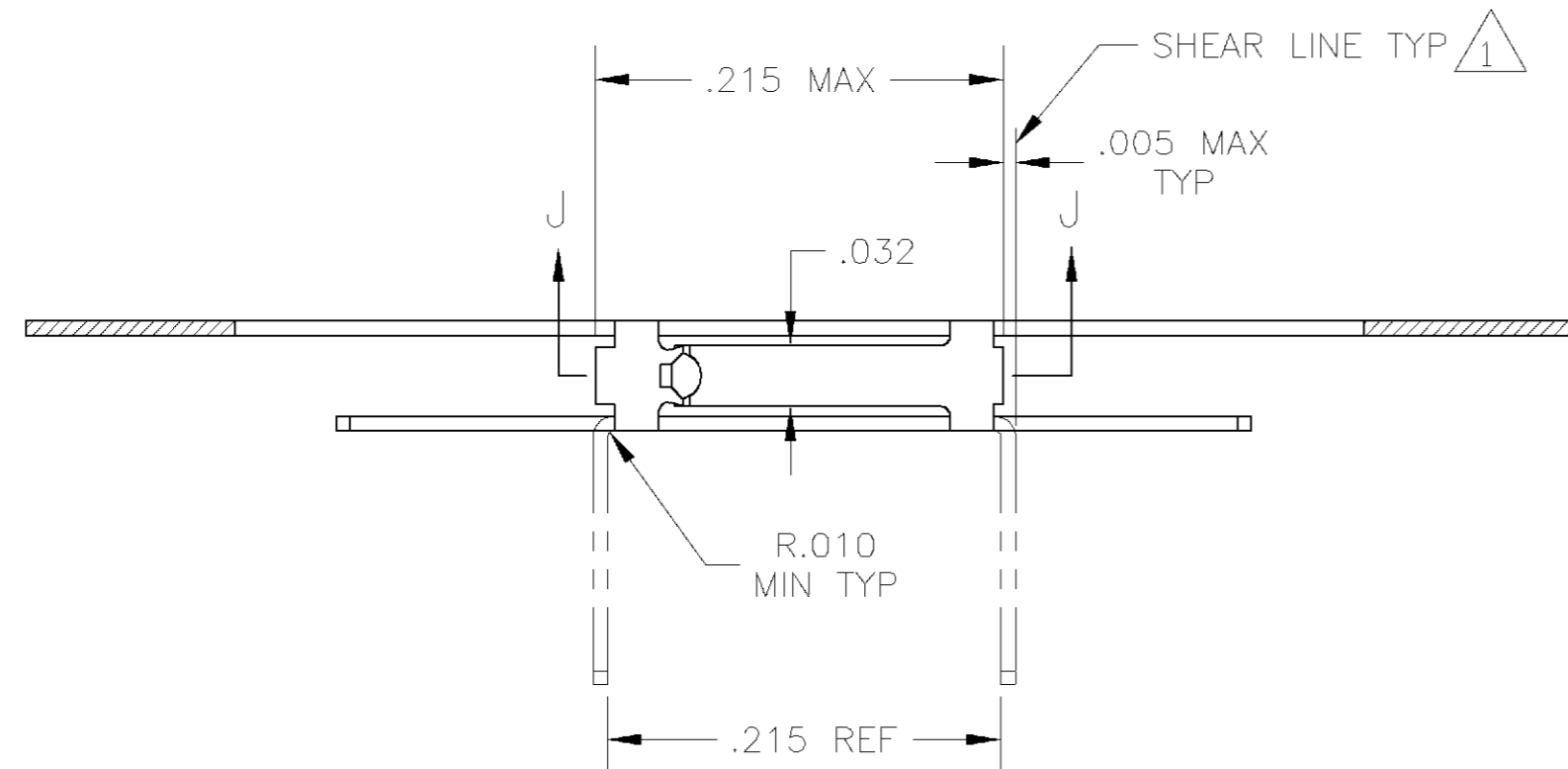
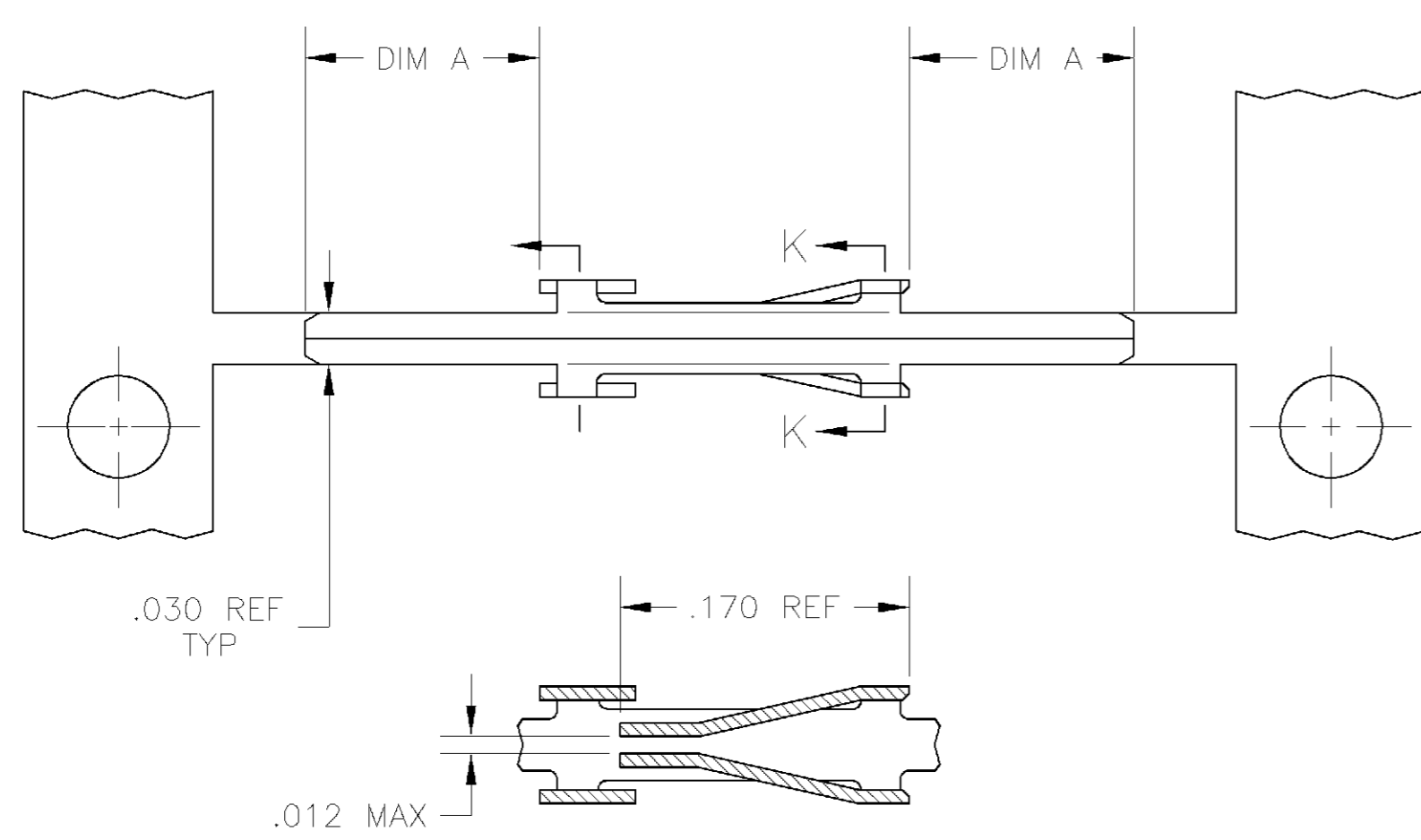

SECTION J-J

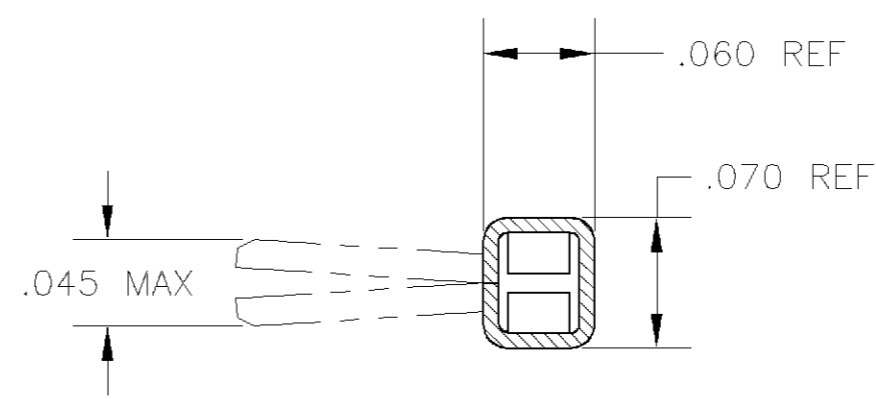

SECTION K-K

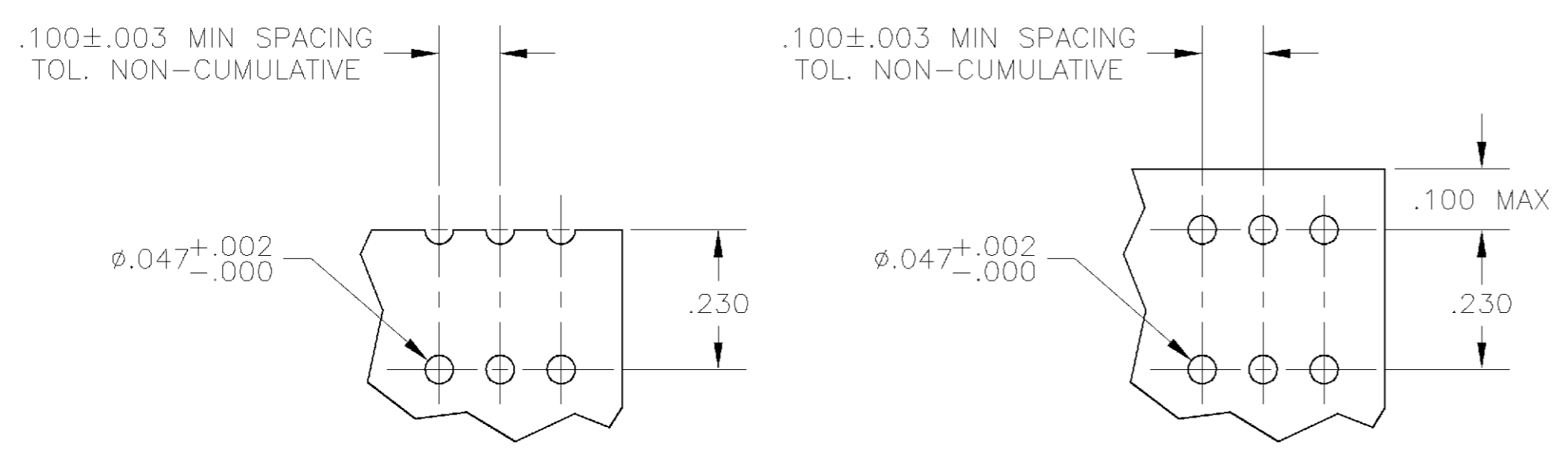

RECOMMENDED PC BOARD LAYOUT  
 SCALE 4:1

THIS DRAWING IS A CONTROLLED DOCUMENT.		DWN	R BROWN	15OCT2001
DIMENSIONS: INCHES		CHK	J OLSON	12OCT01
TOLERANCES UNLESS OTHERWISE SPECIFIED:		APVD	J OLSON	12OCT01
0 PLC	± -	PRODUCT SPEC	NAME	
1 PLC	± -	APPLICATION SPEC	CONTACT, RCPT, MOD II, STRIP, SHORT	
2 PLC	± -	WEIGHT	POINT OF CONTACT, HORIZONTAL, TYPE 'C' ENTRY	
3 PLC	± .005	SCALE	10:1	SHEET 1 OF 2
4 PLC	± -	CUSTOMER DRAWING	REV T	
ANGLES	± -	SIZE CAGE CODE DRAWING NO RESTRICTED TO		
FINISH	-	A2 00779 C=85863		

85863

THIS DRAWING IS UNPUBLISHED. RELEASED FOR PUBLICATION  
 © COPYRIGHT BY TYCO ELECTRONICS CORPORATION. ALL RIGHTS RESERVED.

LOC		DIST		REVISIONS			
P	LTR	DESCRIPTION	DATE	DWN	APVD		
AD	00	SEE SHEET 1	-	-	-		

- 1 CONTACT LEGS SHOWN IN PHANTOM AND SHEAR LINES DEFINE LOOSE PIECE PART.
- 2 .000030 GOLD OVER .000050 NICKEL.
- 3 .000050 GOLD OVER .000050 NICKEL.
- 4 GOLD FLASH OVER .000050 NICKEL ENTIRE CONTACT, .000030 GOLD IN CONTACT AREA ONLY.
- 5 GOLD FLASH OVER .000050 NICKEL ENTIRE CONTACT, .000015 GOLD IN CONTACT AREA ONLY.
- 6 TIN PLATE.
- 7 POINT OF MEASUREMENT FOR PLATING THICKNESS(INSIDE OF CONTACT BEAMS).
- 8 SUPERSEDED BY 85863-4.
- 9 OBSOLETE.

DIM B	DIM A	LOOSE PIECE PART NUMBER	FINISH	STRIP PART NUMBER
.093	.145	2-85866-1	5	2-85863-1
.062	.115	1-85866-2	3	1-85863-2
.062	.115	1-85866-1	5	1-85863-1
.125	.175	1-85866-0	4	1-85863-0
.125	.175	85866-9	6	85863-9
.125	.175	85866-8	2	85863-8
.093	.145	85866-7	4	85863-7
.093	.145	85866-6	6	85863-6
.093	.145	85866-5	2	85863-5
.062	.115	85866-4	4	85863-4
.062	.115	85866-3	6	85863-3
.062	.115	85866-2	2	85863-2

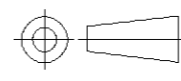
THIS DRAWING IS A CONTROLLED DOCUMENT.		DWN R BROWN 15OCT01	 Tyco Electronics Corporation City, State, Zip	
DIMENSIONS: INCHES		CHK J OLSON 12OCT01		
TOLERANCES UNLESS OTHERWISE SPECIFIED:		APVD J OLSON 12OCT01	NAME CONTACT, RCPT, MOD II, STRIP, SHORT POINT OF CONTACT, HORIZONTAL, TYPE 'C' ENTRY	
		PRODUCT SPEC -	-	
MATERIAL		APPLICATION SPEC -	SIZE A2	CAGE CODE 00779
FINISH		WEIGHT -	DRAWING NO C=85863	RESTRICTED TO -
CUSTOMER DRAWING			SCALE 1:1	SHEET 2 OF 2