

THIS DRAWING IS UNPUBLISHED. RELEASED FOR PUBLICATION, 19
 © COPYRIGHT 19 BY AMP INCORPORATED. ALL INTERNATIONAL RIGHTS RESERVED.

| LOC | DIST | P | F | ZONE | LTR | DESCRIPTION | DATE | APPD | |
|-----|------|---|---|------|-----|----------------------|------|------|----|
| DF | AO | | | | B | REV PER 0G3D-0627-00 | CT | 7-01 | 56 |
| | | | | | C | REV PER 0G3D-0337-01 | CT | 7-01 | 56 |

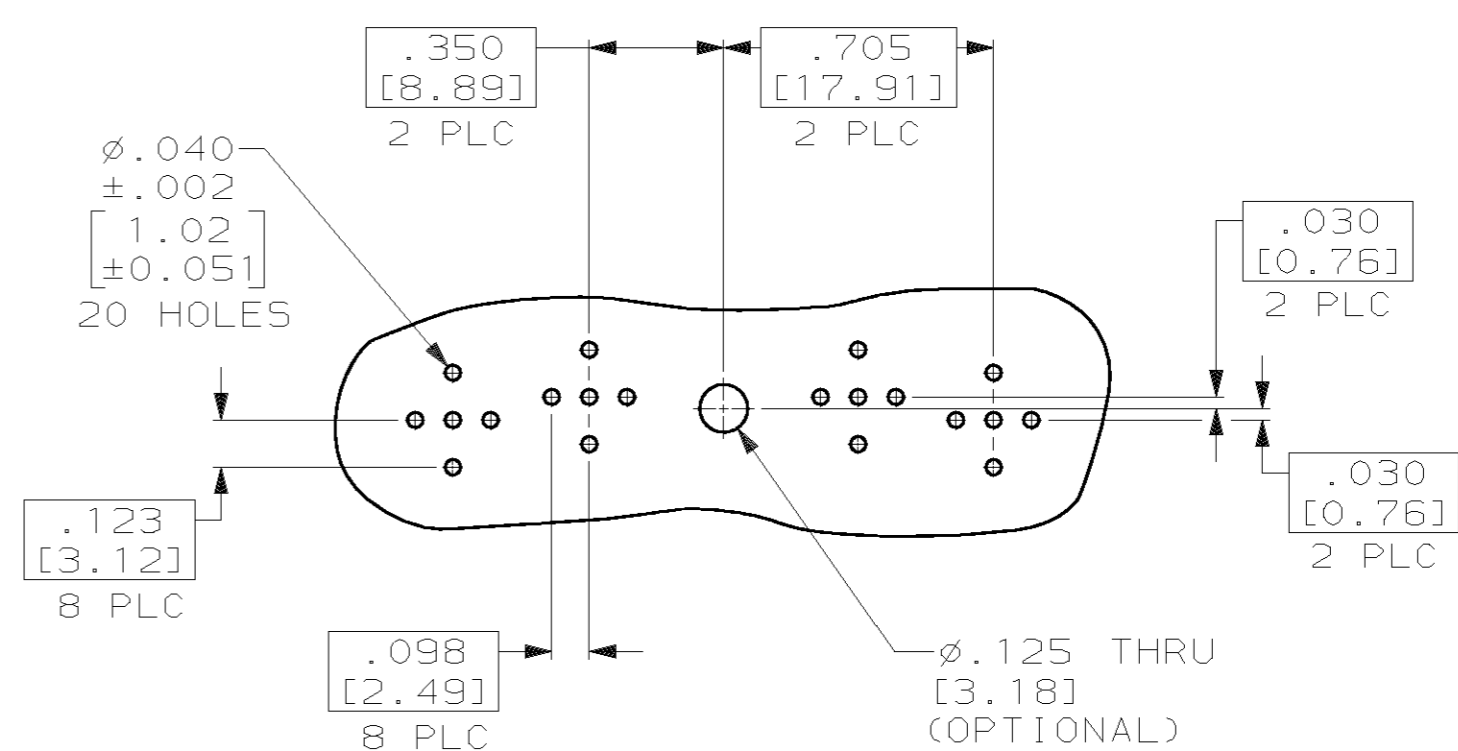
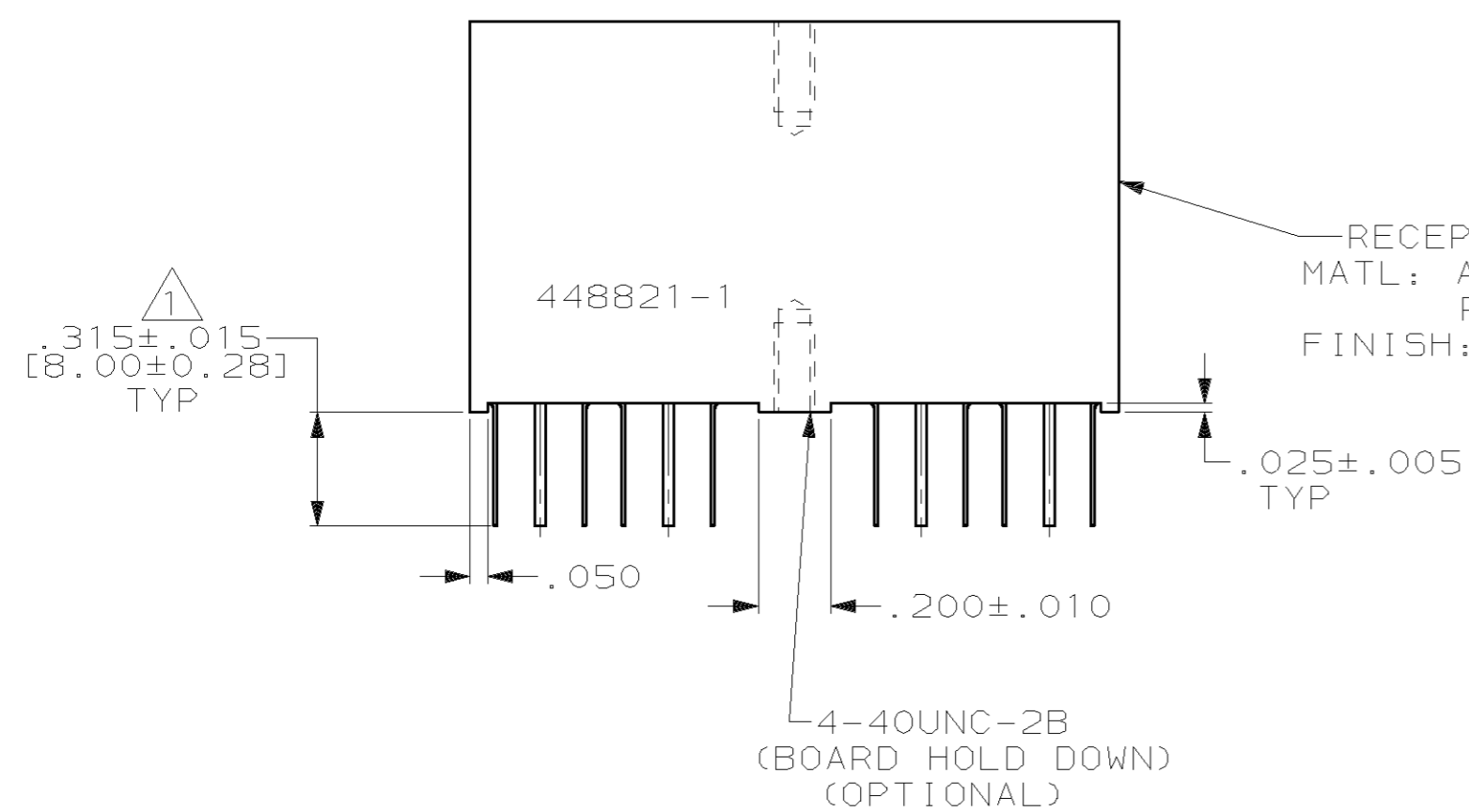
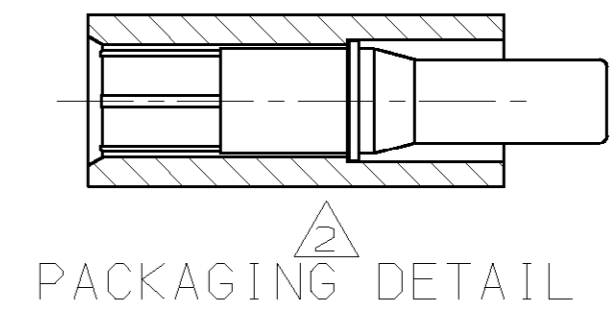
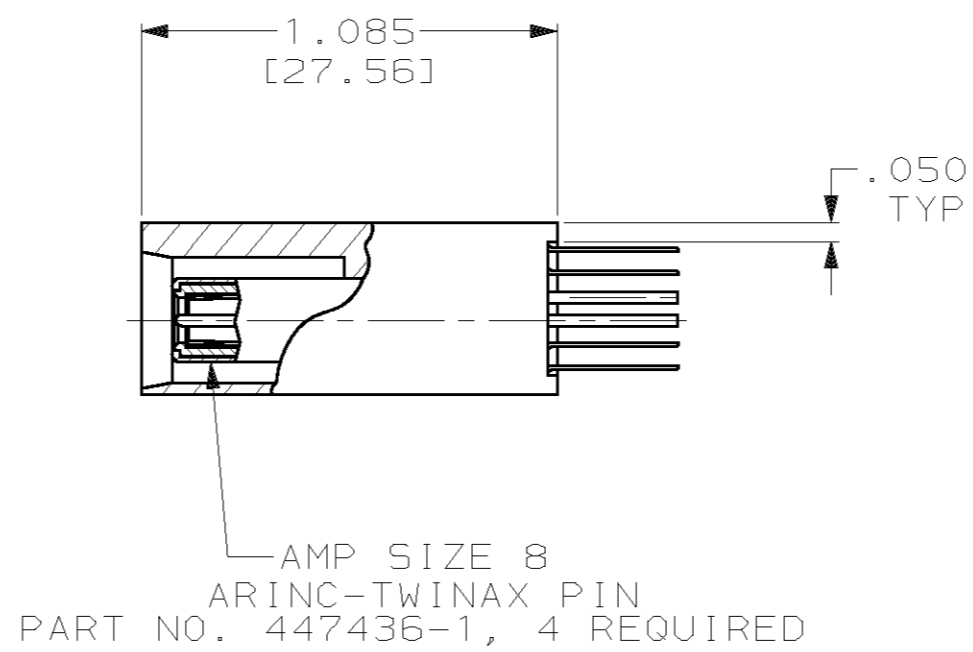
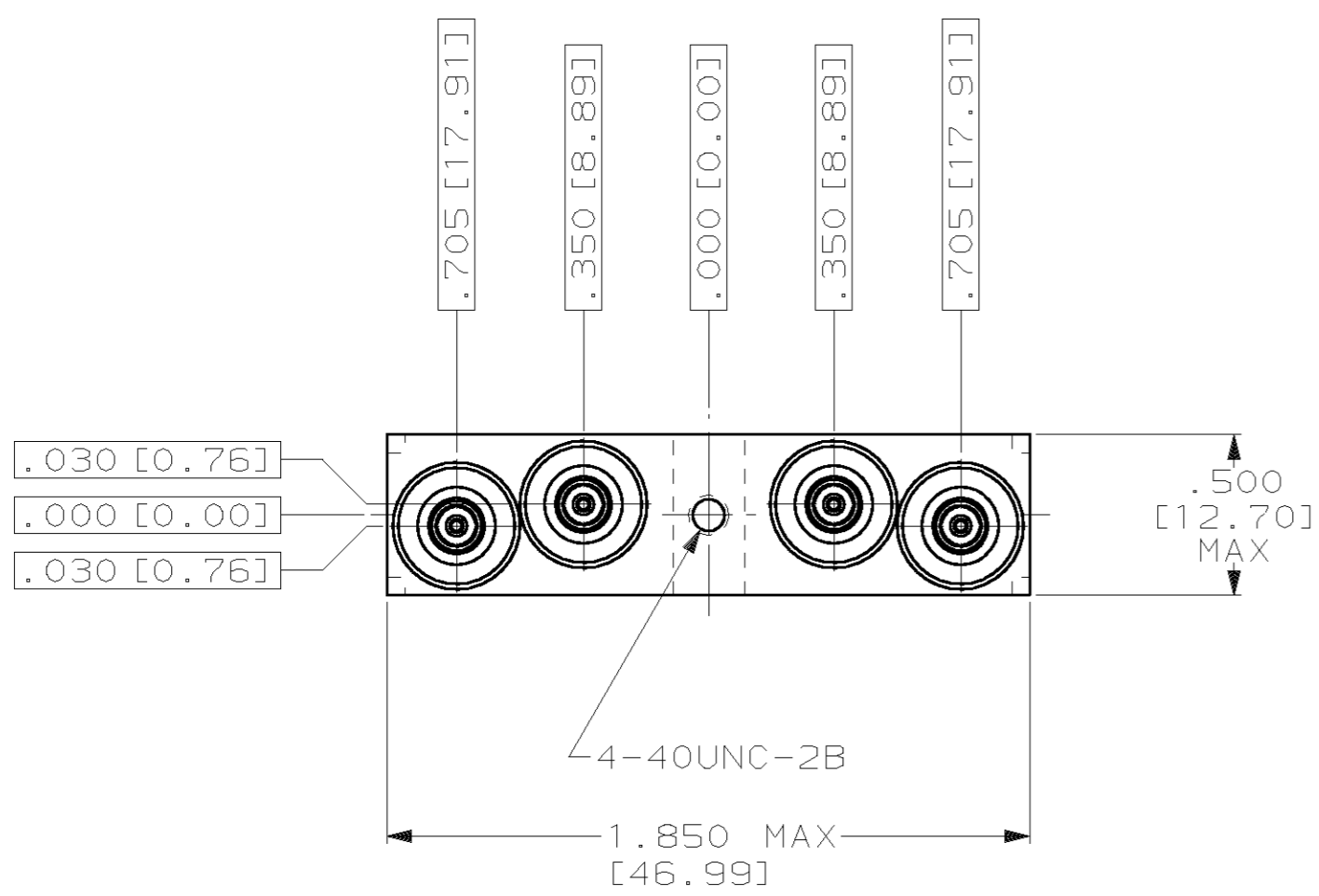

RECOMMENDED PC BOARD LAYOUT

1 SOLDER TINE LENGTH MEASURED FROM REAR OF CONTACT BODY.
 2 CONTACTS SHOWN IN HOUSING FOR ILLUSTRATION ONLY. FOR SHIPPING, CONTACTS ARE LOADED IN HOUSING AS SHOWN IN PACKAGING DETAIL.

| | |
|-------------|-------------|
| AS SHOWN | 448821-1 |
| PART NUMBER | PART NUMBER |

| | | |
|---|---------------------------|---|
| DO NOT SCALE PRINT. UNLESS SPECIFIED DIMENSIONS IN INCHES [mm] TOLERANCES ON: 2 PLC DEC ± - 3 PLC DEC ± .005 [0.13] ANGLES ± - | DR 2-24-93 N. FRITZ | AMP Incorporated Harrisburg, PA 17105-3608 |
| | CHK 2-25-93 S. WRIGHT | |
| MATERIAL SEE CALLOUTS | APPD 2-25-93 S. WRIGHT | NAME RECEPTACLE CONNECTOR KIT, 4 POSN, WITH SIZE 8 ARINC-TWINAX PINS |
| | APPD 2-25-93 S. WRIGHT | PRODUCT SPEC - |
| FINISH SEE CALLOUTS | APPLICATION SPEC - | SIZE C 00779 |
| | WEIGHT - | CAGE CODE 00779 |
| | | DRAWING NO 448821 |
| | | SCALE 2:1 |
| | | SHEET 1 OF 1 |