

REVISIONS					
P	LTR	DESCRIPTION	DATE	DWN	APVD
	8	INITIAL RELEASE	11FEB2020	GK	AK

NOTES: -

1. CHARACTERS: -

0-9, A-Z, +, -, /, ~, ≡

0, 1, 6 & 9 FOLLOWED BY A FULL STOP.

HEIGHT 3.4 - 3.7mm

TOLERANCE (AXIAL) ±0.75

(ROTATIONAL) ±5°

CHEVRON CUT MARKERS: -

CHARACTERS TO BE CENTRALLY DISPOSED ON MARKER FACE AND IN THE ATTITUDE SHOWN RELATIVE TO CHEVRON.

2. MARKER LENGTHS (DIMENSION 'A'): -

WITH SINGLE MARK 5.75 - 6.25

WITH DOUBLE MARK 8.75 - 9.25

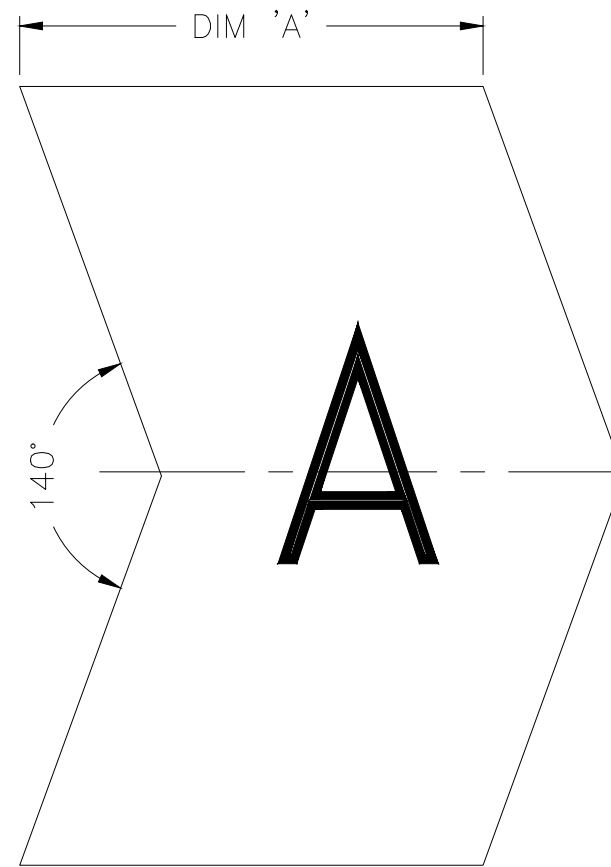

CHEVRON CUT

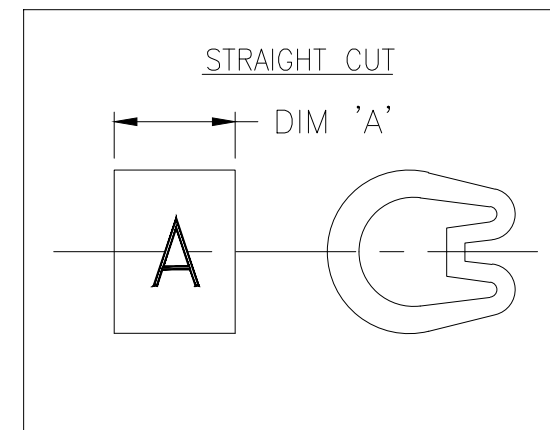
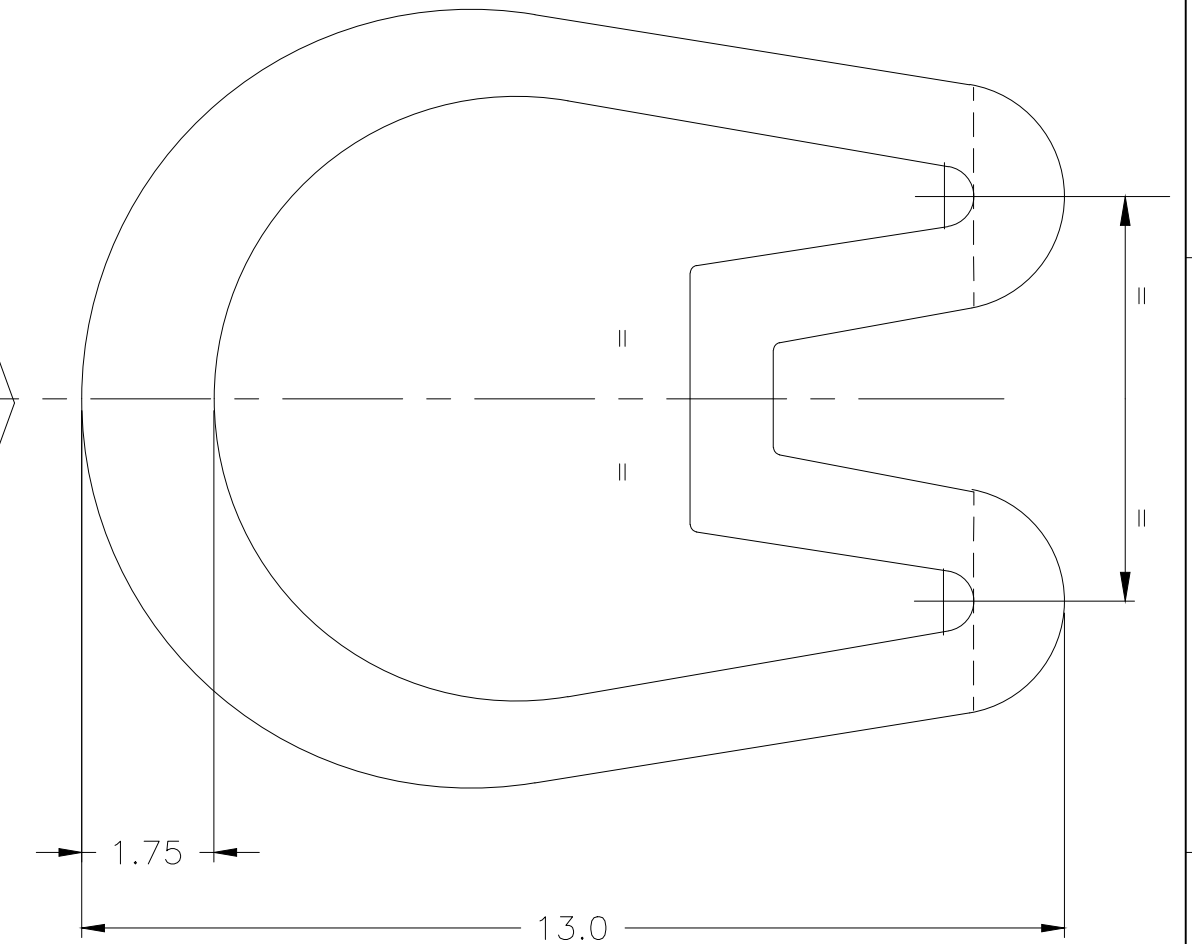

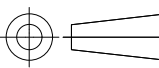
THIS DRAWING IS A CONTROLLED DOCUMENT.		DWN GOPALAKRISHNA H V 11FEB2020	 TE Connectivity		
		CHK ALAN KEAN 11FEB2020			
DIMENSIONS: mm		TOLERANCES UNLESS OTHERWISE SPECIFIED: 0 PLC ± - 1 PLC ± 0.2 2 PLC ± - 3 PLC ± - 4 PLC ± - ANGLES ± -		NAME MARKER Z TYPE SIZE 35 STRAIGHT / CHEVRON CUT	
		MATERIAL PVC 17.34 - 15.7g/250mm		FINISH -	
		PRODUCT SPEC -		APPLICATION SPEC -	
		WEIGHT -		SIZE A3	
		CUSTOMER DRAWING		CAGE CODE 00779	
		DRAWING NO C-1601A0009		RESTRICTED TO -	
		SCALE 10:1		SHEET 1 OF 1	
		REV 8			