

REVISIONS					
P	LTR	DESCRIPTION	DATE	DWN	APVD
	T2	REVISED PER ECR-21-113405	31MAY2022	SS	DH

- 1 CONTINUOUS STRIP ON REELS
- 2 MATING TAB THK IS .033-.030.
- 3 WIRE SIZE IS #18-#14 AWG
- 4 INSULATION RANGE IS .120-.170 DIA.
- 5 THE GAP ON THE ROLLS TO BE IN CONTACT WITH THE TAB FOR THE LENGTH OF THE ROLL BEHIND THE LEAD-IN.

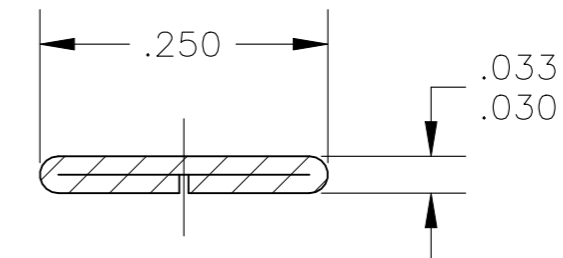

SECTION B-B

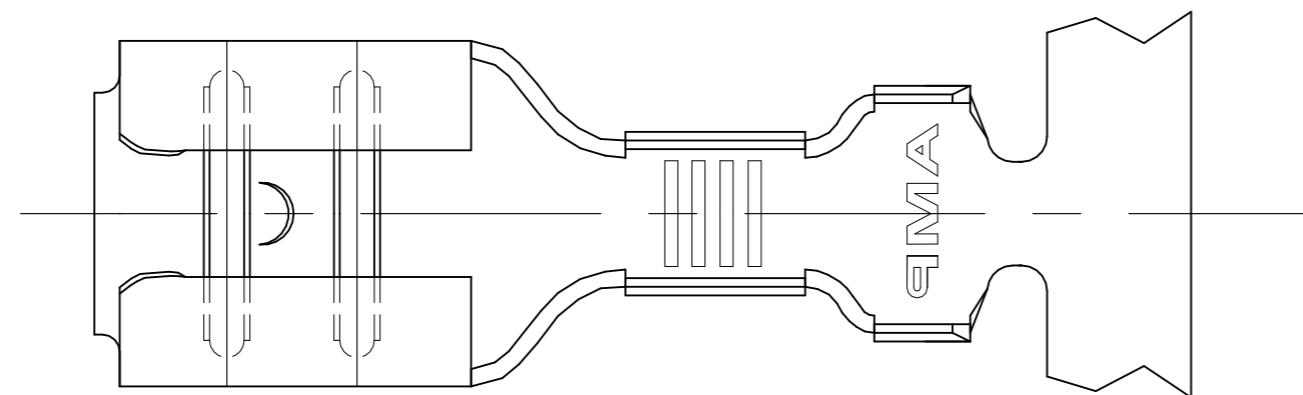
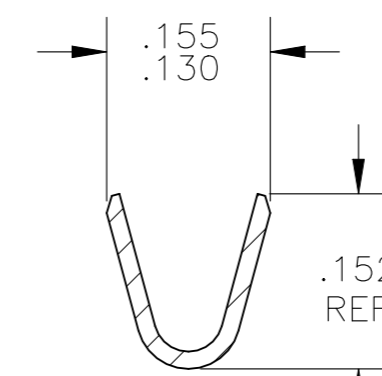
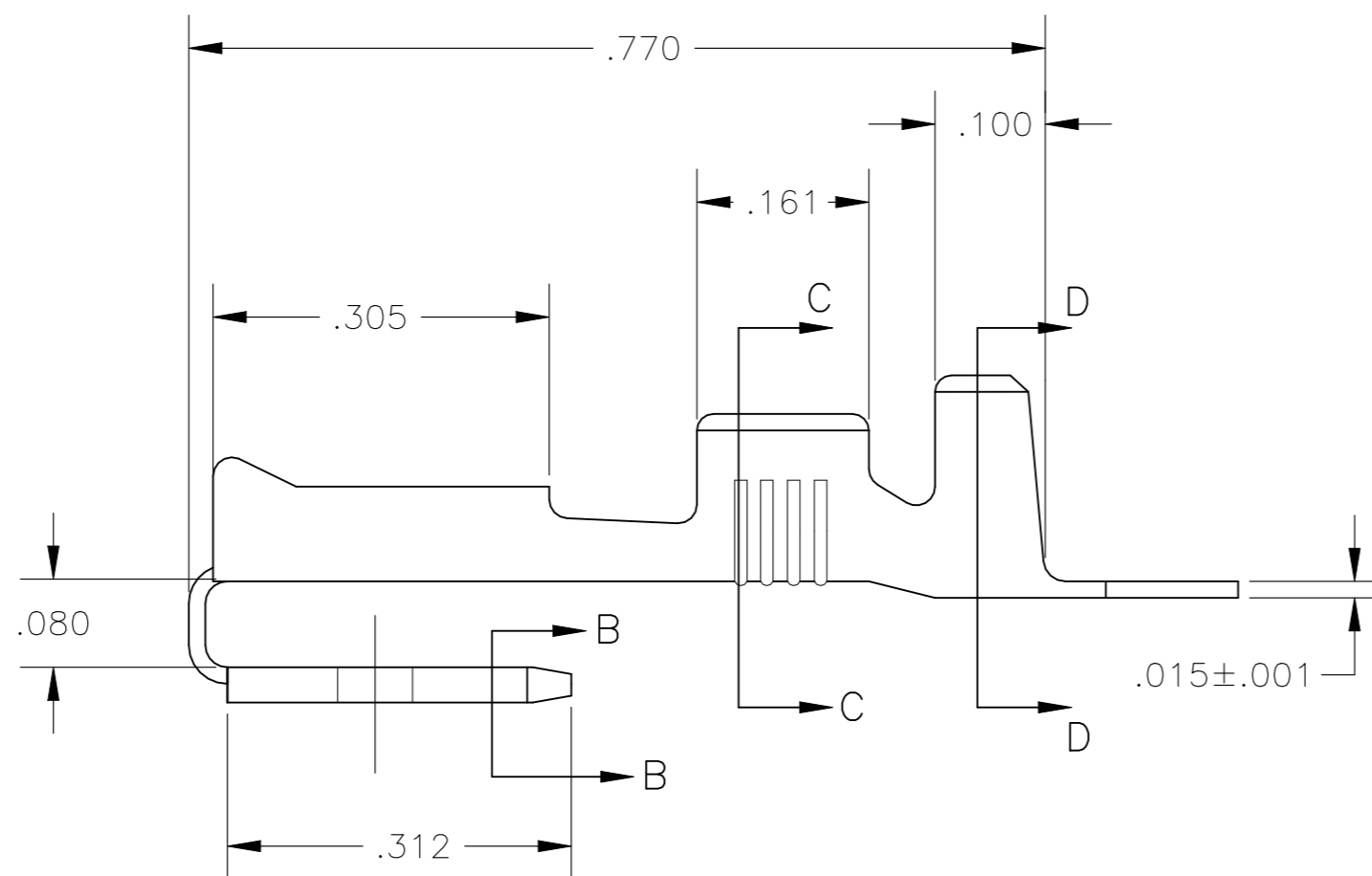

SECTION C-C

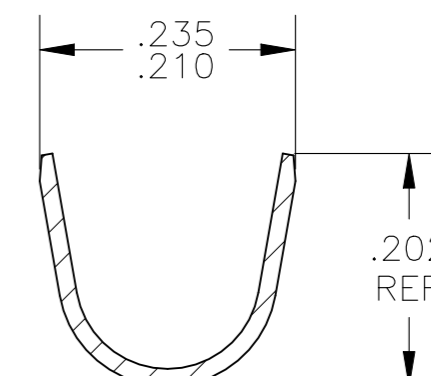

SECTION D-D

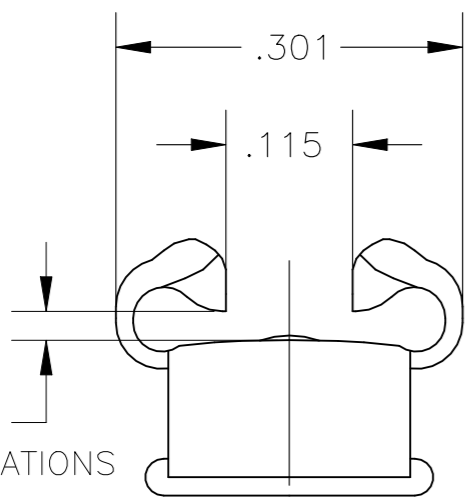

GAP AS REQUIRED TO MEET FORCE SPECIFICATIONS AND .028 MAX

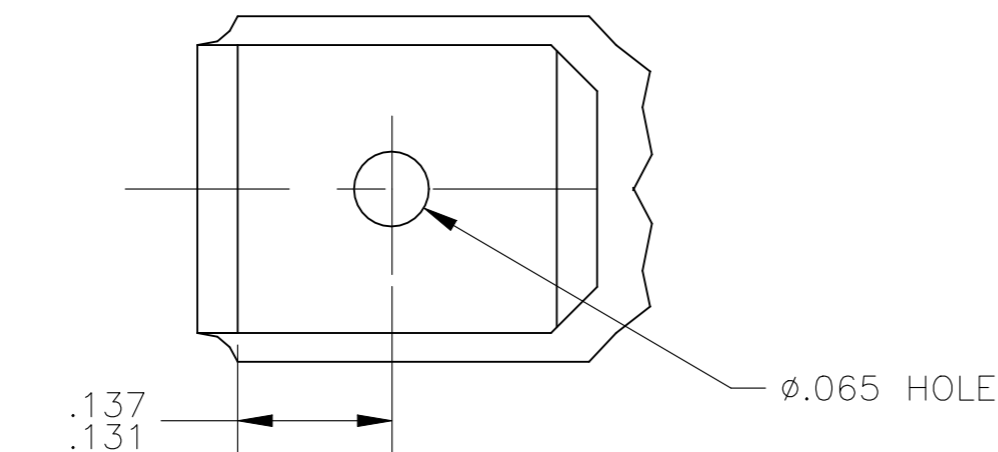

— OBSOLETE	SILVER PLATE	61944-4
— OBSOLETE	PRE TIN PLATE	61944-3
	TIN	61944-2
	—	61944-1
	FINISH	PART NO.

THIS DRAWING IS A CONTROLLED DOCUMENT.		DWN	JR RUTH	26JUL2002	 TE Connectivity	RECEPTACLE, FASTON, PIGGYBACK, 250 SERIES					
DIMENSIONS: INCHES		CHK	P DESANTIS	26JUL02		NAME					
TOLERANCES UNLESS OTHERWISE SPECIFIED:		APVD	P DESANTIS	26JUL02		PRODUCT SPEC					
0 PLC ± - 1 PLC ± - 2 PLC ± - 3 PLC ± .015 4 PLC ± - ANGLES ± -		APPLICATION SPEC		114-2082		SIZE	CAGE CODE	DRAWING NO	RESTRICTED TO		
MATERIAL: BRASS		FINISH: SEE TABLE		WEIGHT	0.000000	A2	00779	C=61944	—		
CUSTOMER DRAWING						SCALE	6:1	SHEET	1 OF 1	REV	T2